

# ***SYLVANIA***

# **SERVICE MANUAL**

## **Sec. 1: Main Section**

- Specifications
- Preparation for Servicing
- Adjustment Procedures
- Schematic Diagrams
- CBA's

## **Sec. 2: Deck Mechanism Section**

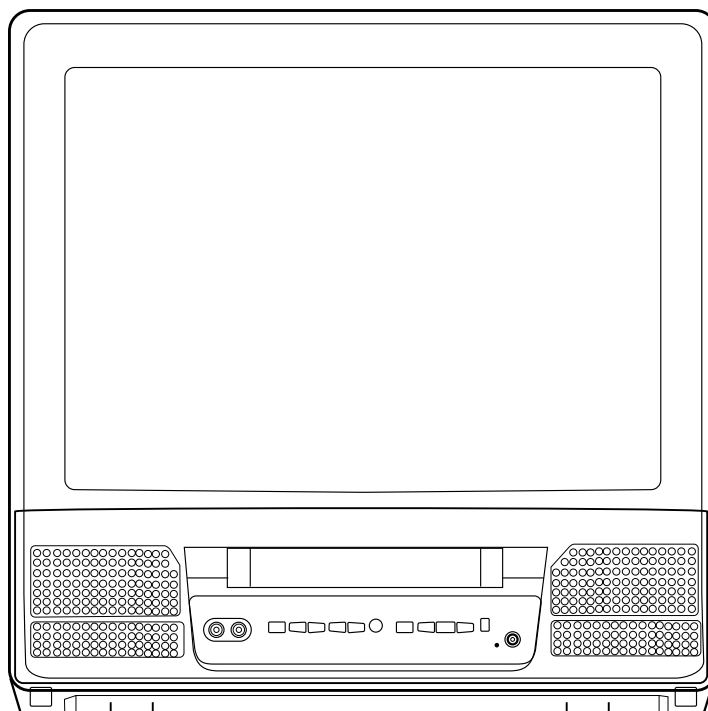
- Standard Maintenance
- Alignment for Mechanism
- Disassembly/Assembly of Mechanism

## **Sec. 3: Exploded views and Parts List Section**

- Exploded views
- Parts List

## **19" COLOR TV/VCR COMBINATION**

# **C6319CD**



**VHS**

## **IMPORTANT SAFETY NOTICE**

**Proper service and repair is important to the safe, reliable operation of all Funai Equipment. The service procedures recommended by Funai and described in this service manual are effective methods of performing service operations. Some of these service special tools should be used when and as recommended.**

**It is important to note that this service manual contains various CAUTIONS and NOTICES which should be carefully read in order to minimize the risk of personal injury to service personnel. The possibility exists that improper service methods may damage the equipment. It also is important to understand that these CAUTIONS and NOTICES ARE NOT EXHAUSTIVE. Funai could not possibly know, evaluate and advise the service trade of all conceivable ways in which service might be done or of the possible hazardous consequences of each way. Consequently, Funai has not undertaken any such broad evaluation. Accordingly, a servicer who uses a service procedure or tool which is not recommended by Funai must first use all precautions thoroughly so that neither his safety nor the safe operation of the equipment will be jeopardized by the service method selected.**

# MAIN SECTION

## 19" COLOR TV/VCR COMBINATION C6319CD

- |   |
|---|
| <b>Sec. 1: Main Section</b> <ul style="list-style-type: none"><li>● Specifications</li><li>● Preparation for Servicing</li><li>● Adjustment Procedures</li><li>● Schematic Diagrams</li><li>● CBA's</li></ul> |
|---|

### TABLE OF CONTENTS

Specifications . . . . .	1-1-1
Important Safety Precautions . . . . .	1-2-1
Standard Notes for Servicing . . . . .	1-3-1
Preparation for Servicing . . . . .	1-4-1
Operating Controls and Functions . . . . .	1-5-1
Cabinet Disassembly Instructions . . . . .	1-6-1
Electrical Adjustment Instructions . . . . .	1-7-1
Block Diagrams . . . . .	1-8-1
Mechanical Trouble Indicator . . . . .	1-8-13
Power Supply Trouble Shooting Guide. . . . .	1-8-15
Schematic Diagrams / CBA's and Test Points . . . . .	1-9-1
Waveforms . . . . .	1-10-1
Wiring Diagrams . . . . .	1-11-1
System Control Timing Charts . . . . .	1-12-1
IC Pin Function Descriptions . . . . .	1-13-1
Lead Identifications . . . . .	1-14-1

# SPECIFICATIONS

✧ Mode-----SP mode unless otherwise specified

✧ Test input terminal

<Except Tuner>-----Video input (1Vp-p)  
Audio input (-10dB)

<Tuner>-----Ant. input (80dB $\mu$ V) Video: 87.5%  
Audio: 25kHz dev (1kHz Sin)

## <DEFLECTION>

Description	Condition	Unit	Nominal	Limit
1. Over Scan	—	%	90	—
2. Linearity	Horizontal	%	—	15
	Vertical	%	—	10
3. High Voltage	—	kV	25	—

## <VIDEO & CHROMA>

Description	Condition	Unit	Nominal	Limit
1. Misconvergence	Center	m/m	—	0.4
	Corner	m/m	—	2.1
	Side	m/m	—	1.4
2. Tint Control Range	—	deg	$\pm 30$	—
3. Contrast Control Range	—	dB	6	—
4. Brightness	APL 100%	ft-L	35	24
5. Color Temperature	—	K	9200	—

## <VCR>

Description	Condition	Unit	Nominal	Limit
1. Horizontal Resolution	(R/P)	Line	230	200
2. Jitter (Low)	(R/P)	$\mu$ S	0.05	0.2
3. S/N Chroma	AM(SP)	(R/P)	dB	38
	PM(SP)	(R/P)	dB	36
4. Wow & Flutter (RMS)	(R/P)	%	0.25	0.5

## <TUNER>

Description	Condition	Unit	Nominal	Limit
1. Video S/N	—	dB	45	40
2. Audio S/N (W/LPF)	—	dB	43	40

## <AUDIO>

All items are measured across 8Ω resistor at speaker output terminal.

Description	Condition	Unit	Nominal	Limit
1. Audio Output Power (Max.)	(R/P)	W	1.0	0.8
2. Audio S/N (W/LPF)	(R/P)	dB	40	36
3. Audio Distortion (W/LPF)	(R/P)	%	3.0	5.0
4. Audio Freq. Response (-10dB Ref. 1KHz)	200Hz (R/P)	dB	-2.0	-2.0 ± 5.0
	8kHz (R/P)	dB	0	0 ± 6.0

**Note:** Nominal specifications represent the design specifications. All units should be able to approximate these. Some will exceed and some may drop slightly below these specifications. Limit specifications represent the absolute worst condition that still might be considered acceptable. In no case should a unit fail to meet limit specifications.

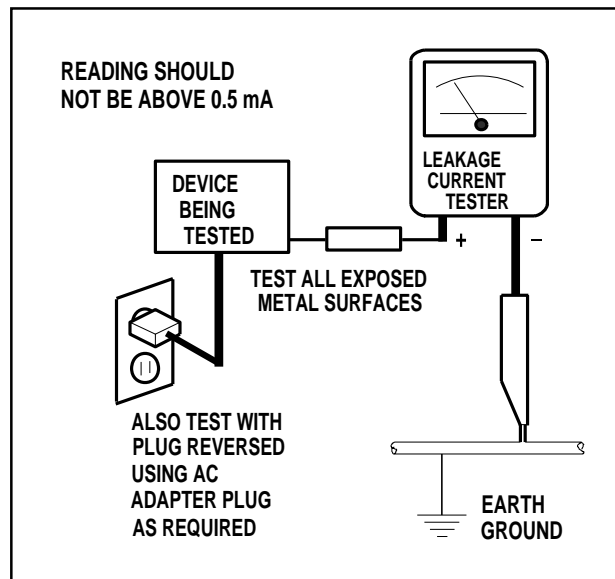
# IMPORTANT SAFETY PRECAUTIONS

Prior to shipment from the factory, our products are strictly inspected for recognized product safety and electrical codes of the countries in which they are to be sold. However, in order to maintain such compliance, it is equally important to implement the following precautions when a set is being serviced.

## Safety Precautions for TV Circuit

1. **Before returning an instrument to the customer**, always make a safety check of the entire instrument, including, but not limited to, the following items:
  - a. Be sure that no built-in protective devices are defective and have been defeated during servicing. (1) Protective shields are provided on this chassis to protect both the technician and the customer. Correctly replace all missing protective shields, including any removed for servicing convenience. (2) When reinstalling the chassis and/or other assembly in the cabinet, be sure to put back in place all protective devices, including but not limited to, nonmetallic control knobs, insulating fishpapers, adjustment and compartment covers/shields, and isolation resistor/capacitor networks. **Do not operate this instrument or permit it to be operated without all protective devices correctly installed and functioning. Servicers who defeat safety features or fail to perform safety checks may be liable for any resulting damage.**
  - b. Be sure that there are no cabinet openings through which an adult or child might be able to insert their fingers and contact a hazardous voltage. Such openings include, but are not limited to, (1) spacing between the picture tube and the cabinet mask, (2) excessively wide cabinet ventilation slots, and (3) an improperly fitted and/or incorrectly secured cabinet back cover.
  - c. **Antenna Cold Check** - With the instrument AC plug removed from any AC source, connect an electrical jumper across the two AC plug prongs. Place the instrument AC switch in the on position. Connect one lead of an ohmmeter to the AC plug prongs tied together and touch the other ohmmeter lead in turn to each tuner antenna input exposed terminal screw and, if applicable, to the coaxial connector. If the measured resistance is less than 1.0 megohm or greater than 5.2 megohm, an abnormality exists that must be corrected before the instrument is returned to the customer. Repeat this test with the instrument AC switch in the off position.
  - d. **Leakage Current Hot Check** - With the instrument completely reassembled, plug the AC line cord directly into a 120V AC outlet. (Do not use an isolation transformer during this test.) Use a leak-

age current tester or a metering system that complies with American National Standards Institute (ANSI) C101.1 Leakage Current for Appliances and Underwriters Laboratories (UL) 1410, (50.7). With the instrument AC switch first in the on position and then in the off position, measure from a known earth ground (metal water pipe, conduit, etc.) to all exposed metal parts of the instrument (antennas, handle brackets, metal cabinet, screw heads, metallic overlays, control shafts, etc.), especially any exposed metal parts that offer an electrical return path to the chassis. Any current measured must not exceed 0.5 milli-ampere. Reverse the instrument power cord plug in the outlet and repeat the test.



**ANY MEASUREMENTS NOT WITHIN THE LIMITS SPECIFIED HEREIN INDICATE A POTENTIAL SHOCK HAZARD THAT MUST BE ELIMINATED BEFORE RETURNING THE INSTRUMENT TO THE CUSTOMER OR BEFORE CONNECTING THE ANTENNA OR ACCESSORIES.**

- e. **X-Radiation and High Voltage Limits** - Because the picture tube is the primary potential source of X-radiation in solid-state TV receivers, it is specially constructed to prohibit X-radiation emissions. For continued X-radiation protection, the replacement picture tube must be the same type as the original. Also, because the picture tube shields and mounting hardware perform an X-radiation protection function, they must be correctly in place. High voltage must be measured each time servic-

ing is performed that involves B+, horizontal deflection or high voltage. Correct operation of the X-radiation protection circuits also must be reconfirmed each time they are serviced. (X-radiation protection circuits also may be called "horizontal disable" or "hold down.") Read and apply the high voltage limits and, if the chassis is so equipped, the X-radiation protection circuit specifications given on instrument labels and in the Product Safety & X-Radiation Warning note on the service data chassis schematic. High voltage is maintained within specified limits by close tolerance safety-related components/adjustments in the high-voltage circuit. If high voltage exceeds specified limits, check each component specified on the chassis schematic and take corrective action.

2. Read and comply with all caution and safety-related notes on or inside the receiver cabinet, on the receiver chassis, or on the picture tube.

3. **Design Alteration Warning** - Do not alter or add to the mechanical or electrical design of this TV receiver. Design alterations and additions, including, but not limited to circuit modifications and the addition of items such as auxiliary audio and/or video output connections, might alter the safety characteristics of this receiver and create a hazard to the user. Any design alterations or additions will void the manufacturer's warranty and may make you, the servicer, responsible for personal injury or property damage resulting therefrom.

4. **Picture Tube Implosion Protection Warning** - The picture tube in this receiver employs integral implosion protection. For continued implosion protection, replace the picture tube only with one of the same type number. Do not remove, install, or otherwise handle the picture tube in any manner without first putting on shatterproof goggles equipped with side shields. People not so equipped must be kept safely away while picture tubes are handled. Keep the picture tube away from your body. Do not handle the picture tube by its neck. Some "in-line" picture tubes are equipped with a permanently attached deflection yoke; because of potential hazard, do not try to remove such "permanently attached" yokes from the picture tube.

5. **Hot Chassis Warning** -

a. Some TV receiver chassis are electrically connected directly to one conductor of the AC power cord and maybe safety-serviced without an isolation transformer only if the AC power plug is inserted so that the chassis is connected to the ground side of the AC power source. To confirm that the AC power plug is inserted correctly, with an AC voltmeter, measure between the chassis and a known

earth ground. If a voltage reading in excess of 1.0V is obtained, remove and reinsert the AC power plug in the opposite polarity and again measure the voltage potential between the chassis and a known earth ground.

b. Some TV receiver chassis normally have 85V AC(RMS) between chassis and earth ground regardless of the AC plug polarity. This chassis can be safety-serviced only with an isolation transformer inserted in the power line between the receiver and the AC power source, for both personnel and test equipment protection.


c. Some TV receiver chassis have a secondary ground system in addition to the main chassis ground. This secondary ground system is not isolated from the AC power line. The two ground systems are electrically separated by insulation material that must not be defeated or altered.

6. Observe original lead dress. Take extra care to assure correct lead dress in the following areas: a. near sharp edges, b. near thermally hot parts-be sure that leads and components do not touch thermally hot parts, c. the AC supply, d. high voltage, and e. antenna wiring. Always inspect in all areas for pinched, out of place, or frayed wiring. Check AC power cord for damage.

7. Components, parts, and/or wiring that appear to have overheated or are otherwise damaged should be replaced with components, parts, or wiring that meet original specifications. Additionally, determine the cause of overheating and/or damage and, if necessary, take corrective action to remove any potential safety hazard.

8. **Product Safety Notice** - Some electrical and mechanical parts have special safety-related characteristics which are often not evident from visual inspection, nor can the protection they give necessarily be obtained by replacing them with components rated for higher voltage, wattage, etc.. Parts that have special safety characteristics are identified by a (▲) on schematics and in parts lists. Use of a substitute replacement that does not have the same safety characteristics as the recommended replacement part might create shock, fire, and/or other hazards. The Product's Safety is under review continuously and new instructions are issued whenever appropriate. Prior to shipment from the factory, our products are strictly inspected to confirm with the recognized product safety and electrical codes of the countries in which they are to be sold. However, in order to maintain such compliance, it is equally important to implement the following precautions when a set is being serviced.

## Precautions during Servicing

- A.** Parts identified by the (  ) symbol are critical for safety.  
Replace only with part number specified.
- B.** In addition to safety, other parts and assemblies are specified for conformance with regulations applying to spurious radiation. These must also be replaced only with specified replacements.  
Examples: RF converters, RF cables, noise blocking capacitors, and noise blocking filters, etc.
- C.** Use specified internal wiring. Note especially:
  - 1) Wires covered with PVC tubing
  - 2) Double insulated wires
  - 3) High voltage leads
- D.** Use specified insulating materials for hazardous live parts. Note especially:
  - 1) Insulation Tape
  - 2) PVC tubing
  - 3) Spacers
  - 4) Insulators for transistors.
- E.** When replacing AC primary side components (transformers, power cord, etc.), wrap ends of wires securely about the terminals before soldering.
- F.** Observe that the wires do not contact heat producing parts (heatsinks, oxide metal film resistors, fusible resistors, etc.)
- G.** Check that replaced wires do not contact sharp edged or pointed parts.
- H.** When a power cord has been replaced, check that 5~6 kg of force in any direction will not loosen it.
- I.** Also check areas surrounding repaired locations.
- J.** Use care that foreign objects (screws, solder drop-lets, etc.) do not remain inside the set.
- K.** Crimp type wire connector  
When replacing the power transformer in sets where the connections between the power cord and power transformer primary lead wires are performed using crimp type connectors, in order to prevent shock hazards, perform carefully and precisely the following steps.  
Replacement procedure
  - 1) Remove the old connector by cutting the wires at a point close to the connector.  
Important: Do not re-use a connector (discard it).
  - 2) Strip about 15 mm of the insulation from the ends of the wires. If the wires are stranded, twist the strands to avoid frayed conductors.
  - 3) Align the lengths of the wires to be connected. Insert the wires fully into the connector.
  - 4) Use the crimping tool to crimp the metal sleeve at the center position. Be sure to crimp fully to the complete closure of the tool.
- L.** When connecting or disconnecting the VCR connectors, first, disconnect the AC plug from AC supply socket.



## Safety Check after Servicing

Examine the area surrounding the repaired location for damage or deterioration. Observe that screws, parts and wires have been returned to original positions. Afterwards, perform the following tests and confirm the specified values in order to verify compliance with safety standards.

### 1. Clearance Distance

When replacing primary circuit components, confirm specified clearance distance ( $d$ ) and ( $d'$ ) between soldered terminals, and between terminals and surrounding metallic parts. (See Fig. 1)

**Table 1 : Ratings for selected area**

AC Line Voltage	Region	Clearance Distance ( $d$ ) ( $d'$ )
110 to 130 V	USA or CANADA	$\geq 3.2$ mm (0.126 inches)

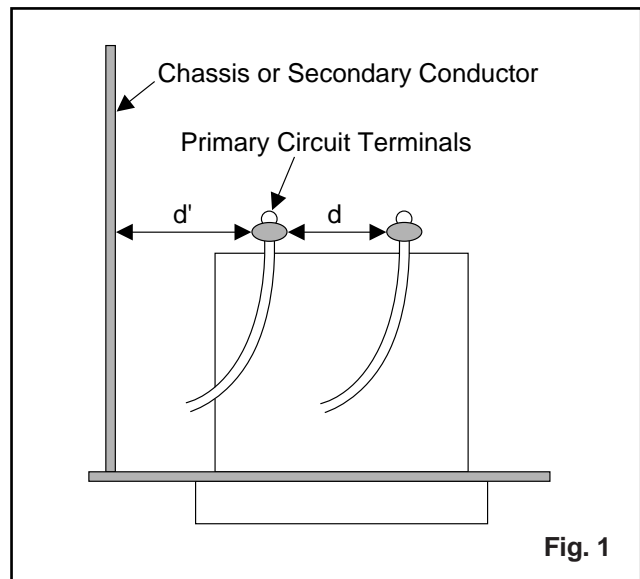
**Note:** This table is unofficial and for reference only. Be sure to confirm the precise values.

### 2. Leakage Current Test

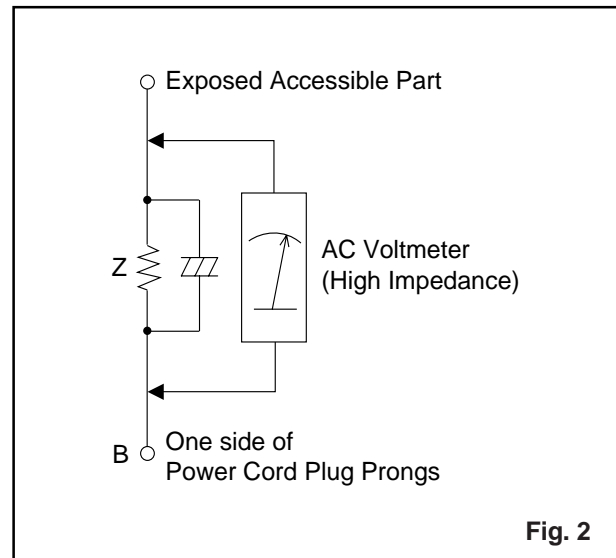
Confirm the specified (or lower) leakage current between B (earth ground, power cord plug prongs) and externally exposed accessible parts (RF terminals, antenna terminals, video and audio input and output terminals, microphone jacks, earphone jacks, etc.).

#### Measuring Method : (Power ON)

Insert load  $Z$  between B (earth ground, power cord plug prongs) and exposed accessible parts. Use an AC voltmeter to measure across both terminals of load  $Z$ . See Fig. 2 and following table.



**Fig. 1**



**Fig. 2**

**Table 2 : Leakage current ratings for selected areas**

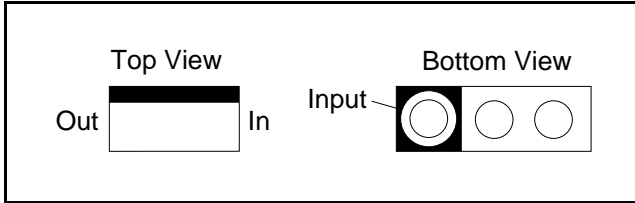
AC Line Voltage	Region	Load $Z$	Leakage Current ( $i$ )	Earth Ground (B) to:
110 to 130 V	USA or CANADA	0.15 $\mu$ F CAP. & 1.5k $\Omega$ RES. connected in parallel	$i \leq 0.5$ mA rms	Exposed accessible parts

**Note:** This table is unofficial and for reference only. Be sure to confirm the precise values.

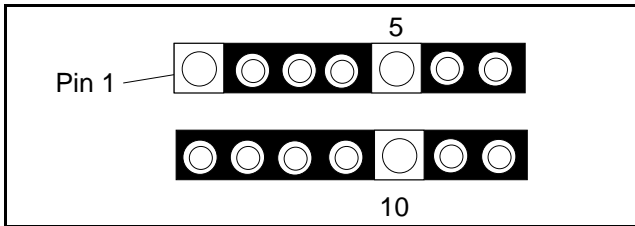
# STANDARD NOTES FOR SERVICING

## Circuit Board Indications

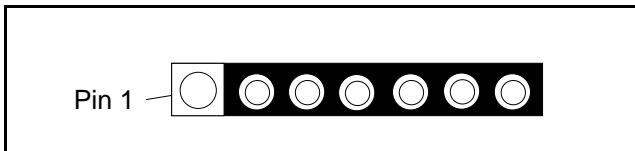
1. The output pin of the 3 pin Regulator ICs is indicated as shown:



2. For other ICs, pin 1 and every 5th pin is indicated as shown:

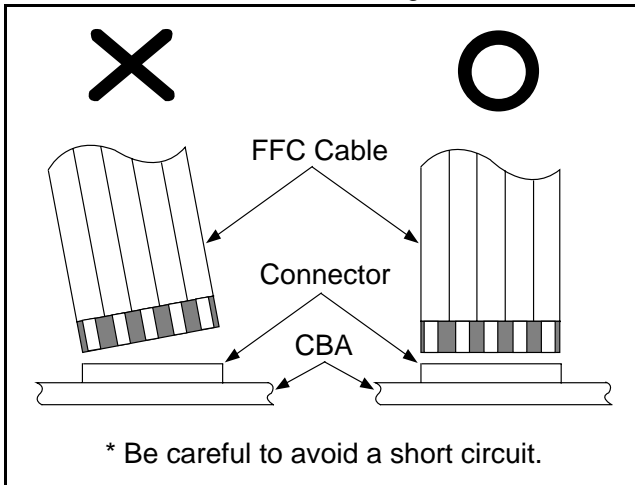


3. The 1st pin of every pin connector are indicated as shown:



## Instructions for Connectors

1. When you connect or disconnect FFC cable (connector), be sure to disconnect the AC cord.
2. FFC cable (connector) should be inserted parallel into the connector, not at an angle.

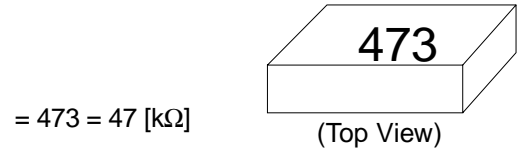


[ CBA= Circuit Board Assembly ]

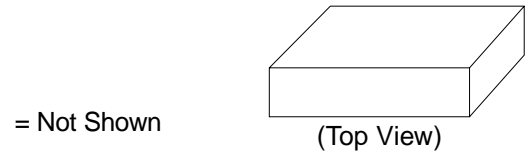
## How to Read the Values of the Rectangular Type Chip Components

Example:

(a) Resistor



(b) Capacitor



### Caution:

Once chip parts (Resistors, Capacitors, Transistors, etc.) are removed, they must not be reused. Always use a new part.

## Replacement Procedures for Leadless (Chip) Components

The Following Procedures are Recommended for the Replacement of the Leadless Components Used in this Unit.

### 1. Preparation for replacement

- a. Soldering Iron  
Use a pencil-type soldering iron (less than 30 watts).
- b. Solder  
Eutectic solder (Tin 63%, Lead 37%) is recommended.
- c. Soldering time  
Do not apply heat for more than 4 seconds.
- d. Preheating  
Leadless capacitor must be preheated before installation. (130°C~150°C, for about two minutes.)

### Notes:

- a. Leadless components must not be reused after removal.
- b. Excessive mechanical stress and rubbing for the component electrode must be avoided.

### 2. Removing the leadless component

Grasp the leadless component body with tweezers and alternately apply heat to both electrodes. When the solder on both electrodes has melted, remove leadless component with a twisting motion.

**Notes:**

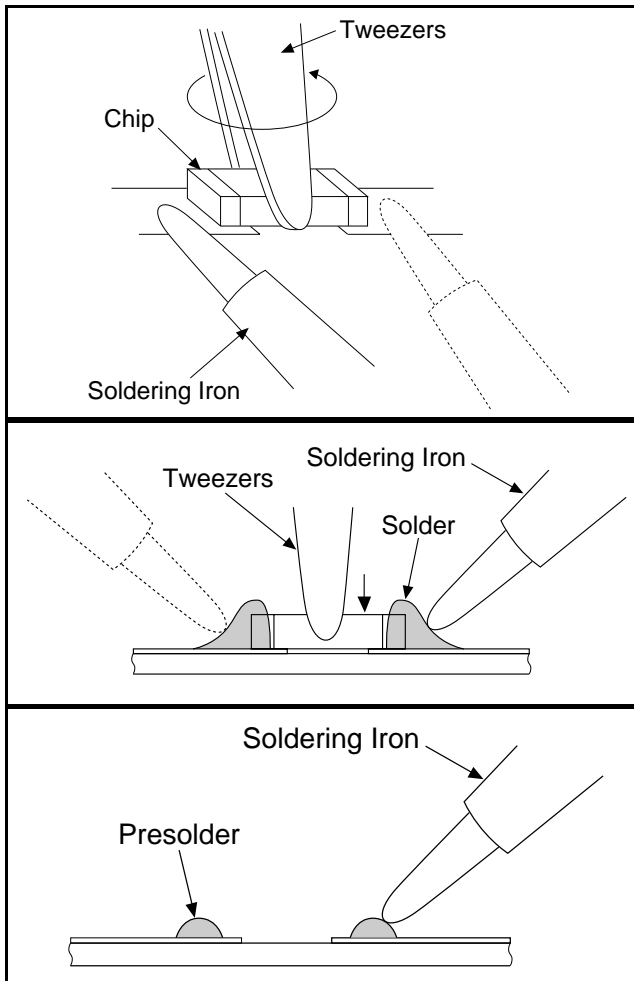
- a. Do not attempt to lift the component off the board until the component is completely disconnected from the board by the twisting action.
- b. Take care not to break the copper foil on the printed board

**3. Installing the leadless component**

- a. Presolder the contact points of the circuit board.
- b. Press the part downward with tweezers and solder both electrodes as shown below.

**Note:**

Do not glue the replacement leadless component to the circuit board.



**How to Remove / Install Flat Pack IC**

**Caution:**

- 1. Do not apply the hot air to the chip parts around the Flat Pack-IC for over 6 seconds as damage may occur to the chip parts. Put Masking Tape around the Flat Pack-IC to protect other parts from damage. (Fig. S-1-2)

- 2. The Flat Pack-IC on the CBA is affixed with glue, so be careful not to break or damage the foil of each pin or solder lands under the IC when removing it.

**1. Removal**

**With Hot - Air Flat Pack - IC Desoldering Machine:**

- a. Prepare the Hot - Air Flat Pack - IC Desoldering Machine, then apply hot air to Flat Pack - IC (about 5~6 seconds). (Fig. S-1-1)
- b. Remove the Flat Pack- IC with tweezers while applying the hot air.

**With Soldering Iron:**

- a. Using desoldering braid, remove the solder from all pins of the Flat Pack - IC. When you use solder flux which is applied to all pins of the Flat Pack - IC, you can remove it easily. (Fig. S-1-3)
- b. Lift each lead of the Flat Pack - IC upward one by one, using a sharp pin or wire to which solder will not adhere (iron wire). When heating the pins, use a fine tip soldering iron or a hot air Desoldering Machine. (Fig. S-1-4)

**With Iron Wire:**

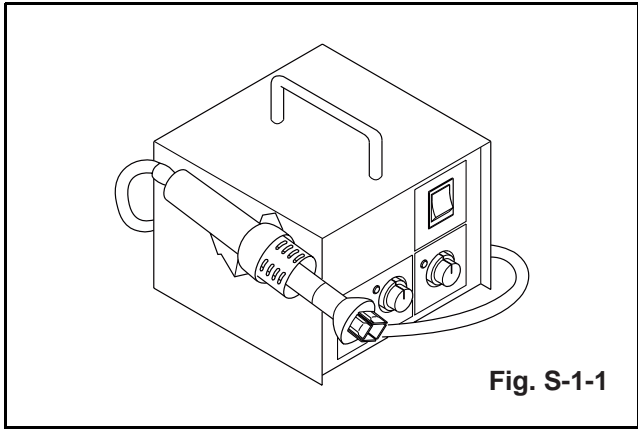
- a. Using desoldering braid, remove the solder from all pins of the Flat Pack - IC. When you use solder flux which is applied to all pins of the Flat Pack - IC, you can remove it easily. (Fig. S-1-3)
- b. Affix the wire to a workbench or solid mounting point, as shown in Fig. S-1-5.
- c. Pull up on the wire as the solder melts so as to lift the IC leads from the CBA contact pads, while heating the pins using a fine tip soldering iron or hot air blower.

**Note:**

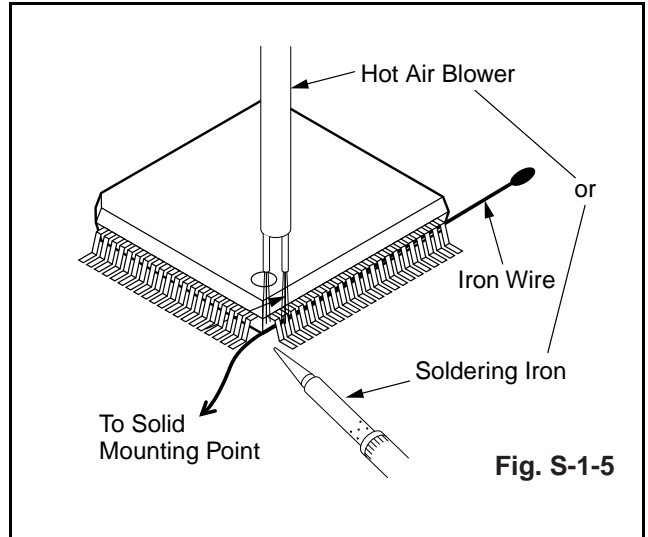
When using a soldering iron, care must be taken to ensure that the Flat Pack - IC is not being held by glue, or when it is removed from the CBA, it may be damaged if force is used.

**2. Installation**

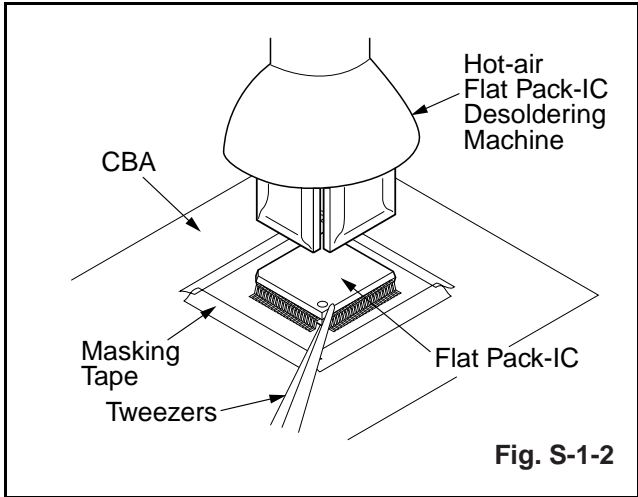
- a. Using desoldering braid, remove the solder from the foil of each pin of the Flat Pack - IC on the CBA, so you can install a replacement Flat Pack - IC more easily.
- b. The "●" mark on the Flat Pack - IC indicates pin 1 (See Fig. S-1-6). Make sure this mark matches the 1 on the CBA when positioning for installation. Then pre - solder the four corners of the Flat Pack-IC (See Fig. S-1-7).
- c. Solder all pins of the Flat Pack - IC. Make sure that none of the pins have solder bridges.



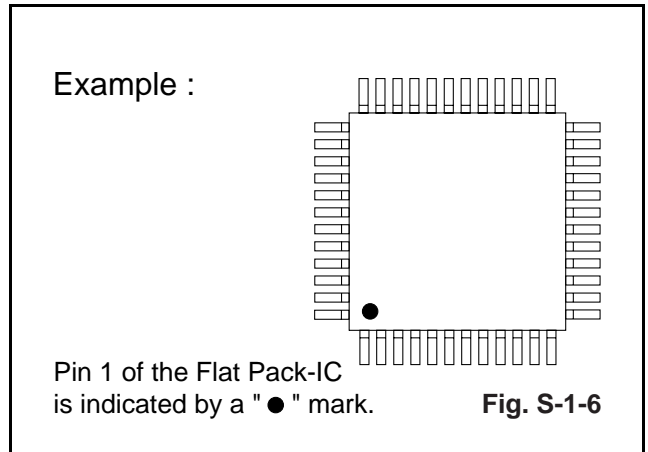
**Fig. S-1-1**



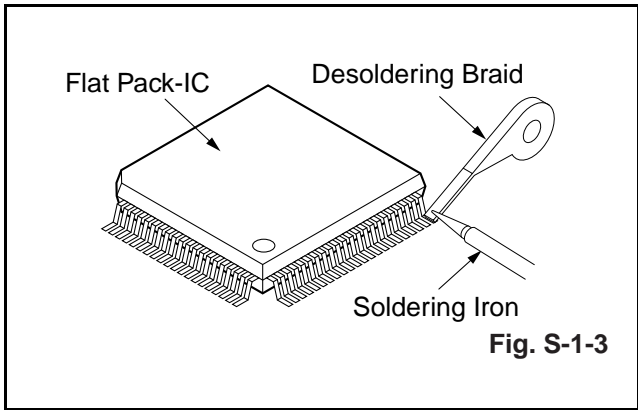
**Fig. S-1-5**



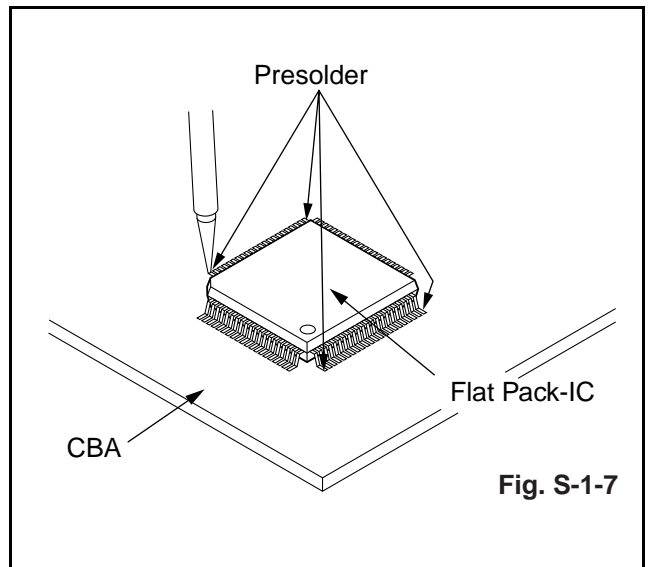
**Fig. S-1-2**



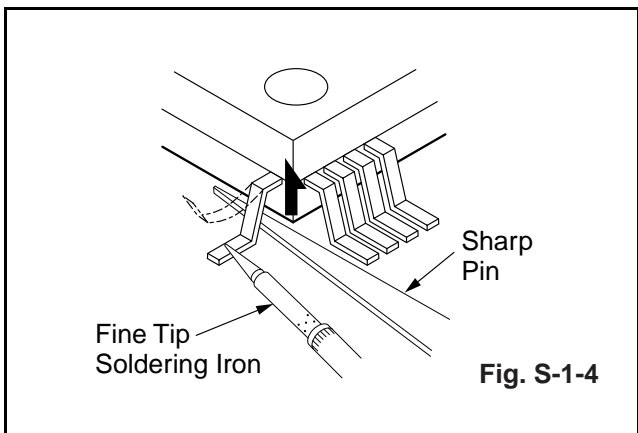
**Fig. S-1-6**



**Fig. S-1-3**



**Fig. S-1-7**



**Fig. S-1-4**

# Instructions for Handling Semiconductors

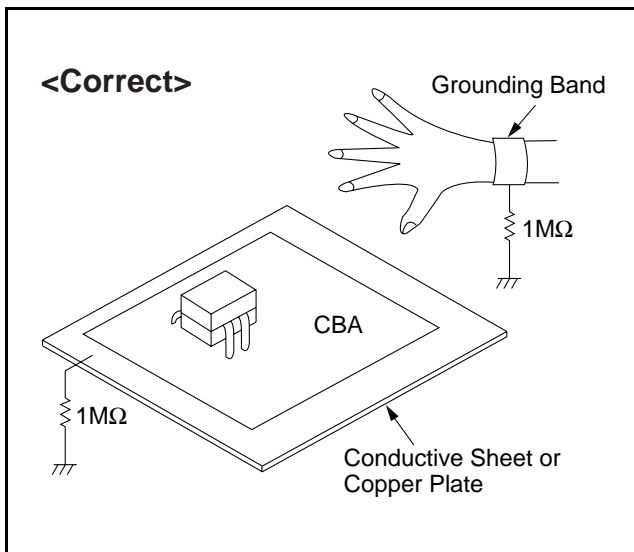
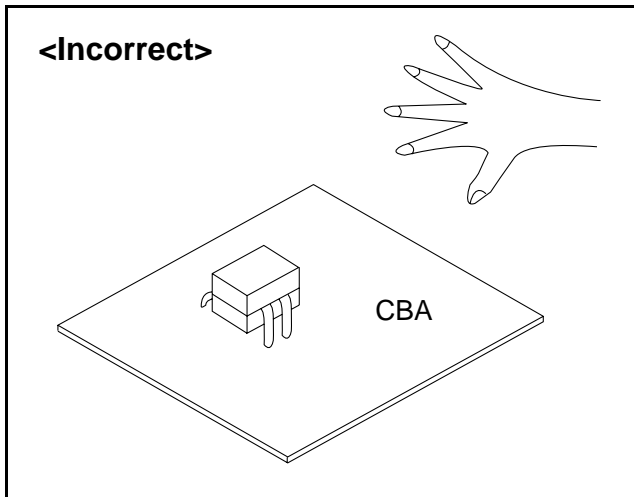
Electrostatic breakdown of the semiconductors may occur due to a potential difference caused by electrostatic charge during unpacking or repair work.

## Ground for Human Body

Be sure to wear a grounding band ( $1M\Omega$ ) that is properly grounded to remove any static electricity that may be charged on the body.

## Ground for Work Bench

Be sure to place a conductive sheet or copper plate with proper grounding ( $1M\Omega$ ) on the work bench or other surface, where the semiconductors are to be placed. Because the static electricity charge on the clothing will not escape through the body grounding band, be careful to avoid contacting semiconductors to clothing.



# PREPARATION FOR SERVICING

## How to Enter the Service Mode

### Caution: 1

- Optical sensors system are used for Tape Start and End Sensor on this equipment. Read this page carefully and prepare as described on this page before starting to service; otherwise, the unit may operate unexpectedly.

### Preparing: 1

- Cover Q202 (START SENSOR) and Q201 (END SENSOR) with Insulation Tape or enter the service mode to activate Sensor Inhibition automatically.

**Note:** Avoid playing, rewinding or fast forwarding the tape to its beginning or end, because both Tape End Sensors are not active.

## How to Enter the Service Mode

- Turn power on.
- Use service remote control unit and press WAKE-UP/SLEEP key. (See page 1-7-1)
- When entering the service mode, one of the number (1, 2 or 4) will display at corners of the screen.
- During the service mode, electrical adjustment mode can be selected by remote control key. (Service remote control unit).

Details are as follows.

Key	Adjustment Mode
<b>MENU</b>	Picture adjustment mode: Press the MENU button to change from BRT (Bright), *CNT (Contrast), *COL (Color), *TNT (Tint) and *V-T. Press CH UP/DOWN key to display Initial Value. *Marked items are not necessary to adjust normally.
<b>0</b>	C-Trap and Y DL Time/Y SW LPF adjustment mode: See adjustment instructions page 1-7-2.
<b>1</b>	No need to use.
<b>2</b>	H adjustment mode: See adjustment instructions page 1-7-2.
<b>3</b>	No need to use.
<b>4</b>	Auto record mode: Perform recording (15 Sec.)-->Stop-->Rewind (Zero return) automatically.
<b>5</b>	Head switching point adjustment mode: See adjustment instructions page 1-7-5.

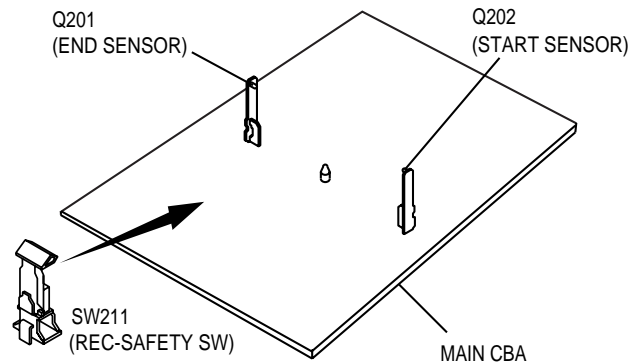
Key	Adjustment Mode
<b>6</b>	No need to use.
<b>7</b>	Purity check mode: Shows Red, Green, Blue or White cyclically on the screen each time the "7" key is pressed.
<b>8</b>	H. Shift adjustment mode: See adjustment instructions page 1-7-3.
<b>9</b>	V.size/V. shift adjustment: See adjustment instructions page 1-7-3.

### Caution: 2

- The deck mechanism assembly is mounted on the Main CBA directly, and SW211 (REC-SAFETY SW) is mounted on the Main CBA. When deck mechanism assembly is removed from the Main CBA due to servicing, this switch can not be operated automatically.

### Preparing: 2

- To eject the tape, press the STOP/EJECT button on the unit (or Remote Control).
- When you want to record during the Service mode, press the Rec button while depressing SW211 (REC-SAFETY SW) on the Main CBA.



# OPERATING CONTROLS AND FUNCTIONS

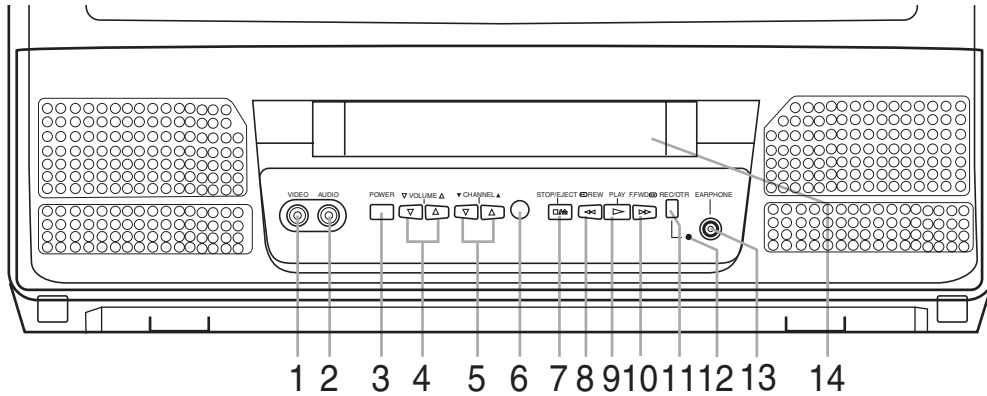
This manual covers 13" and 19". The operation of the two models are exactly the same except the appearance. 19" model is illustrated in this manual.

## NOTE:

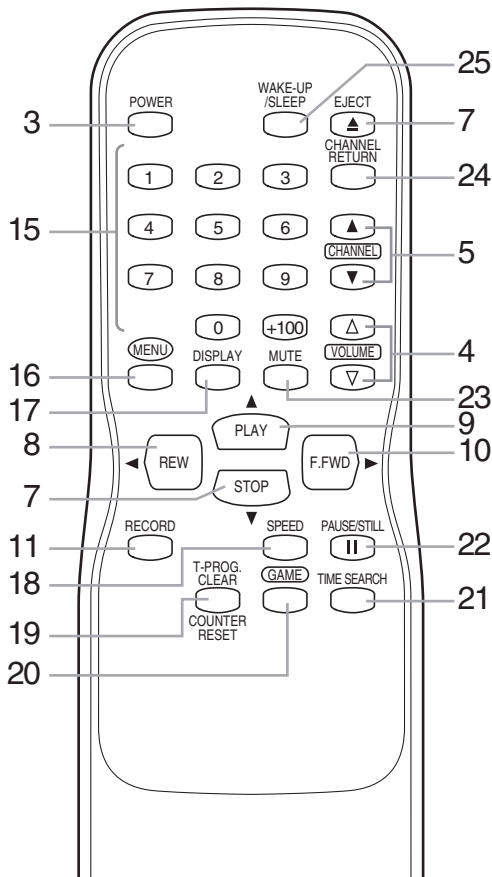
- We do not recommend the use of universal remote controls. Not all of the functions may be controlled with a universal remote control.

If you decide to use a universal remote control with this unit, please be aware that the code number given may not operate this unit. In this case, please call the manufacturer of the universal remote control.

## - TV/VCR FRONT PANEL -



## - REMOTE CONTROL -



**1 VIDEO input jack**– Connect to the video output jack of your video camera or another VCR.

**2 AUDIO input jack**– Connect to the audio output jack of your audio equipment, video camera or another VCR.

**3 POWER button**– Press to turn TV/VCR on and off. Press to activate timer recording.

**4 VOLUME  $\Delta$  /  $\nabla$  buttons**– Adjust the volume level.

**5 CHANNEL  $\Delta$  /  $\nabla$  buttons**– Press to select the desired channels for viewing or recording. You may display the main menu on the TV screen by pressing repeatedly this button on the TV/VCR.

**TRACKING function**– Press to minimize video ‘noise’ (lines or dots on screen) during playback mode.

**6 Remote Sensor Window**– Receives the infrared signals from the remote control.

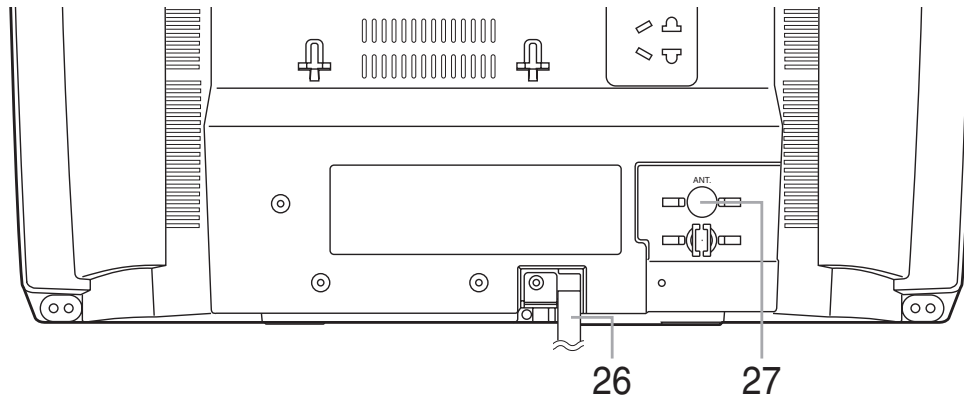
**7 STOP button**– Press to stop the tape motion.

**EJECT button**– Press in the Stop mode to remove tape from TV/VCR.

### **$\nabla$ button**–

- Press to select setting modes from the on screen menu.
- Press to enter digits when setting program. (for example: setting clock or timer program)

**- REAR VIEW -**



**8 REW button**– Press to rewind the tape, or to view the picture rapidly in reverse during playback mode. (Rewind Search)

**◀ button**–

- Press to select a mode from a particular menu. (for example: LANGUAGE or USER’S SET UP)

**9 PLAY button**– Press to begin playback.

**▲ button**–

- Press to select setting modes from the on screen menu.
- Press to enter digits when setting program. (for example: setting clock or timer program)

**10 F.FWD button**– Press to rapidly advance the tape, or to view the picture rapidly in forward during playback mode. (Forward Search)

**▶ button**–

- When setting program (for example: setting clock or timer program), press to determine your selection and proceed to the next step you want to input.
- Press to determine setting modes from on screen menu.
- Press to select a mode from a particular menu. (for example: LANGUAGE or USER’S SET UP)

**11 REC button**– Press for manual recording.

**OTR button**– Activates One Touch Recording. (only on the TV/VCR)

**12 RECORD indicator**– Flashes during recording. Lights up in the Stand-by mode for Timer Recording.

**13 EARPHONE jack**– Connects to earphones (not supplied) for personal listening. The size of jack is 1/8” monaural (3.5mm).

**14 Cassette compartment**

**15 Number buttons**– Press to select desired channels for viewing or recording. To select channels from 1 to 9, first press the 0 button and then 1 to 9.

**+100 button**– When selecting cable channels which are higher than 99, press this button first, then press the last two digits. (To select channel 125, first press the “+100” button then press “2” and “5”).

**16 MENU button**– Press to display the main menu on the TV screen.

**17 DISPLAY button**– Display the counter or the current channel number and current time on the TV screen.

**18 SPEED button**– Press to choose the desired recording speed:SP/SLP.

**19 T-PROG. CLEAR button**– Press to cancel a setting of timer program.

**COUNTER RESET button**– Press to reset counter to 0:00:00.

**20 GAME button**– Sets the game mode and external input mode at the same time.

**21 TIME SEARCH button**– Press to activate Time Search mode.

**22 PAUSE/STILL button**– Press to temporarily stop the tape during the recording or to view a still picture during playback.

**23 MUTE button**– Mutes the sound. Press it again to resume sound.

**24 CHANNEL RETURN button**– Press to go back to the previously viewed channel. For example, pressing this button once will change channel display from 3 (present channel) to 10 (previously viewed channel), and pressing it a second time will return from 10 to 3.

**25 WAKE-UP/SLEEP button**– Sets the Wake up or Sleep Timer.

**26 Power cord**– Connect to a standard AC outlet (120V/60Hz).

**27 ANT. terminal**– Connect to an antenna or cable system.



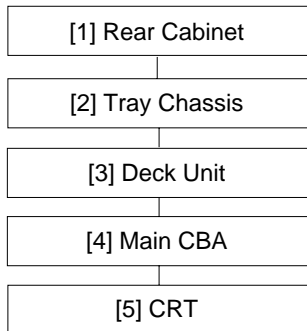
# CABINET DISASSEMBLY INSTRUCTIONS

## 1. Disassembly Flowchart

This flowchart indicates the disassembly steps for the cabinet parts and the CBA in order to gain access to item(s) to be serviced. When reassembling, follow the steps in reverse order. Bend, route and dress the cables as they were.

### Caution !

When removing the CRT, be sure to discharge the Anode Lead of the CRT with the CRT Ground Wire before removing the Anode Cap.



## 2. Disassembly Method

ID/ LOC. No.	PART	REMOVAL		
		Fig. No.	REMOVE/ *UNHOOK/ UNLOCK/RELEASE/ UNPLUG/DESOL- DER	Note
[1]	Rear Cabinet	1, 2	4(S-1), (S-2)	1
[2]	Tray Chassis	3, 5	Anode Cap, CN505, CRT CBA, CN601, CN801, CN571	2
[3]	Deck Unit	3, 5	7(S-3), 2(S-4), Desolder (CL201, CL401, CL402, CL403)	3
[4]	Main CBA	3, 5	6(S-5)	4
[5]	CRT	4	4(S-6)	5

↓            ↓            ↓            ↓            ↓  
 (1)        (2)        (3)        (4)        (5)

(1): Order of steps in Procedure. When reassembling, follow the steps in reverse order. These numbers are also used as the Identification (location) No. of parts in Figures.

(2): Parts to be removed or installed.

(3): Fig. No. showing Procedure of Part Location.

(4): Identification of part to be removed, unhooked, unlocked, released, unplugged, unclamped, or desoldered.

S=Screw, P=Spring, L=Locking Tab, CN=Connector, \*=Unhook, Unlock, Release, Unplug, or Desolder

2(S-2) = two screws (S-2)

(5): Refer to the following Reference Notes in the Table.

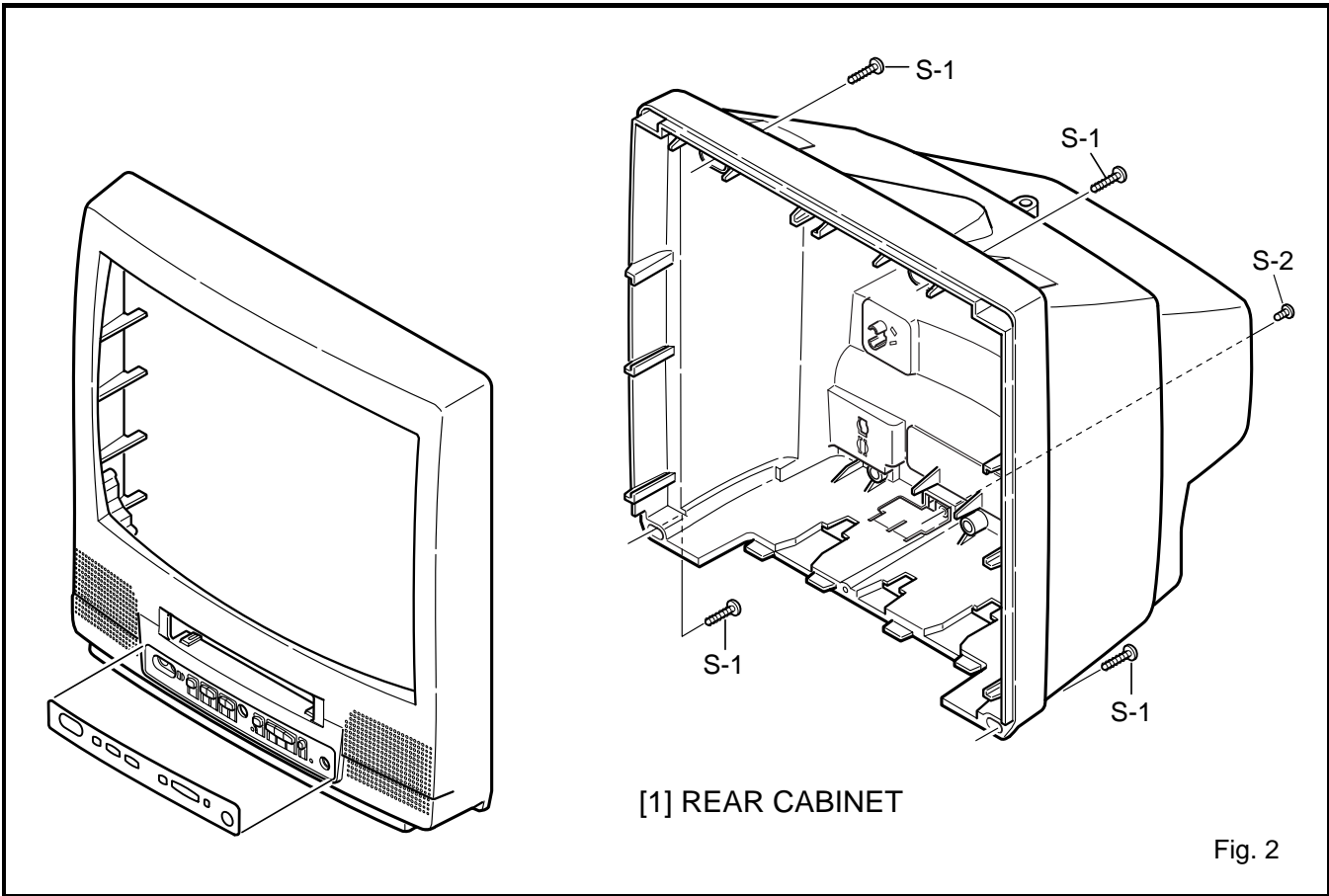
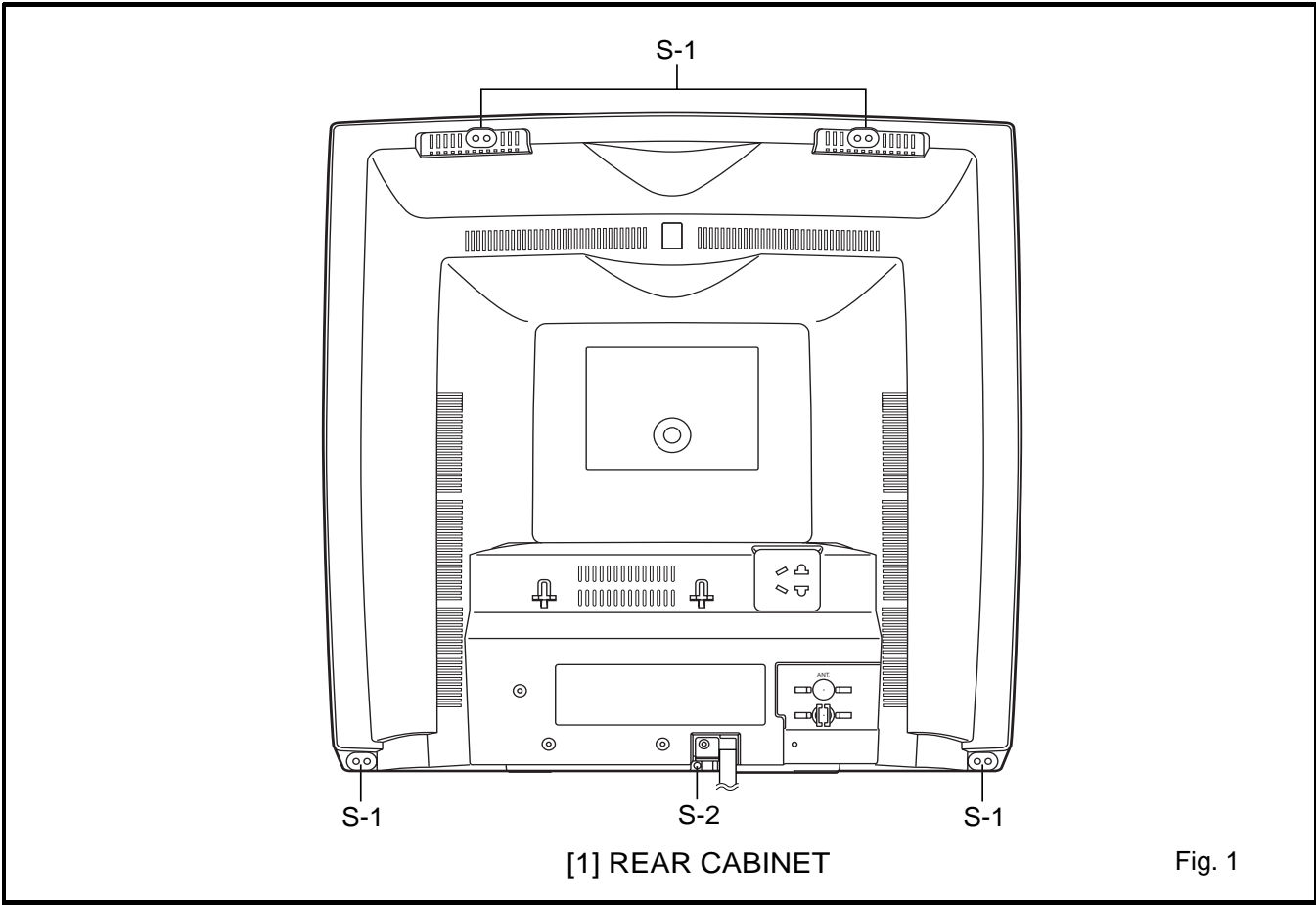
### Reference Notes in the Table

1. Removal of the Rear Cabinet.  
Remove screws 4(S-1) and (S-2).

### Caution !

Discharge the Anode Lead of the CRT with the CRT Ground Wire before removing the Anode Cap.

2. Removal of the Tray Chassis.  
Discharge the Anode Lead of the CRT with the CRT Ground Wire before removing the Anode Cap. Disconnect the following: Anode Cap, CN505, CRT CBA, CN601, CN571 and CN801. Then, pull the Tray Chassis backward.
3. Removal of the Deck Unit.  
Remove screws 7(S-3) and 2(S-4). Then, desolder connectors (CL201, CL401, CL402, CL403) and lift up the Deck Unit.
4. Removal of the Main CBA.  
Remove screws 6(S-5) and pull up the Main CBA.
5. Removal of the CRT.  
Remove screws 4(S-6) and pull the CRT backward.



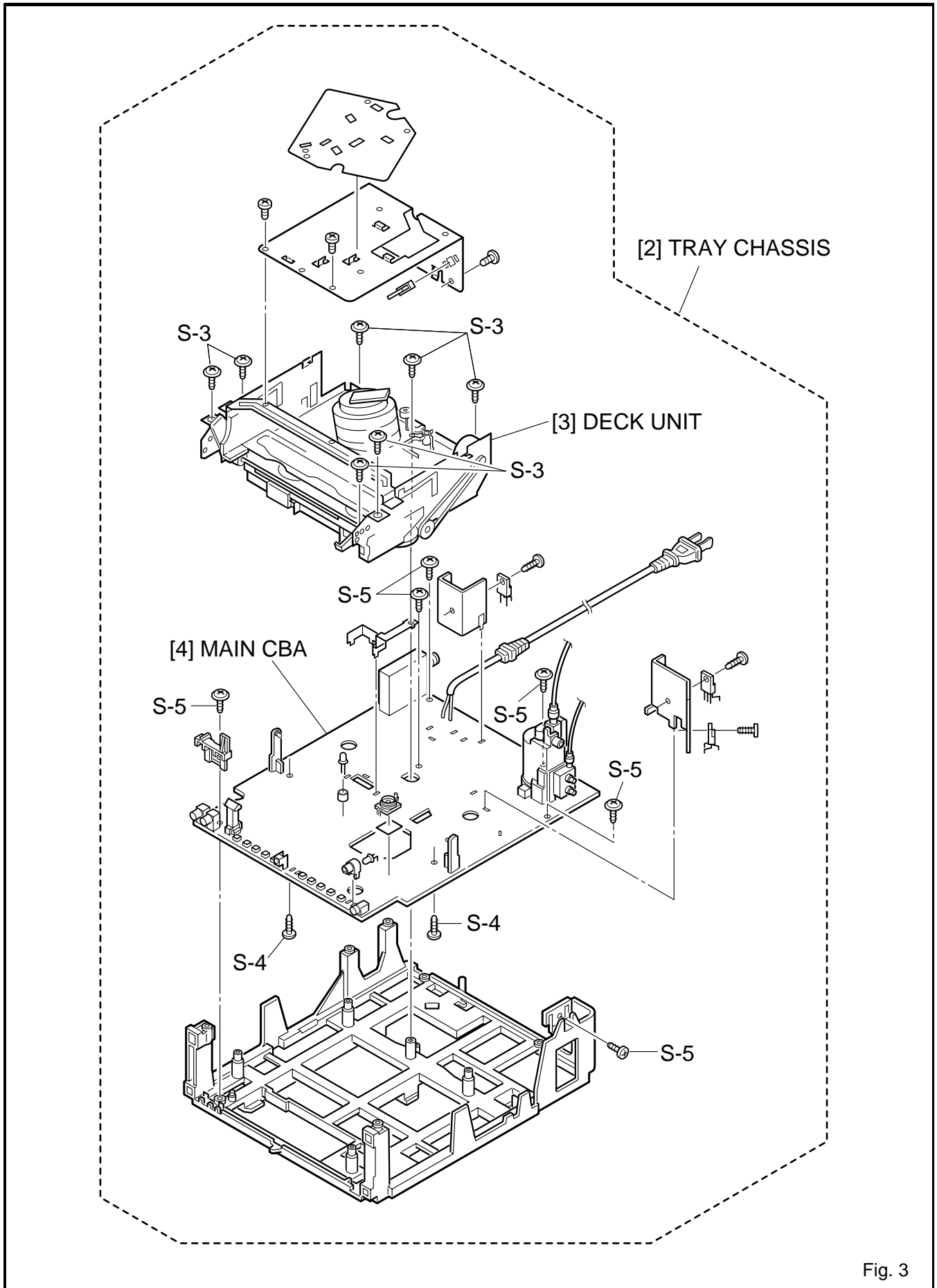


Fig. 3

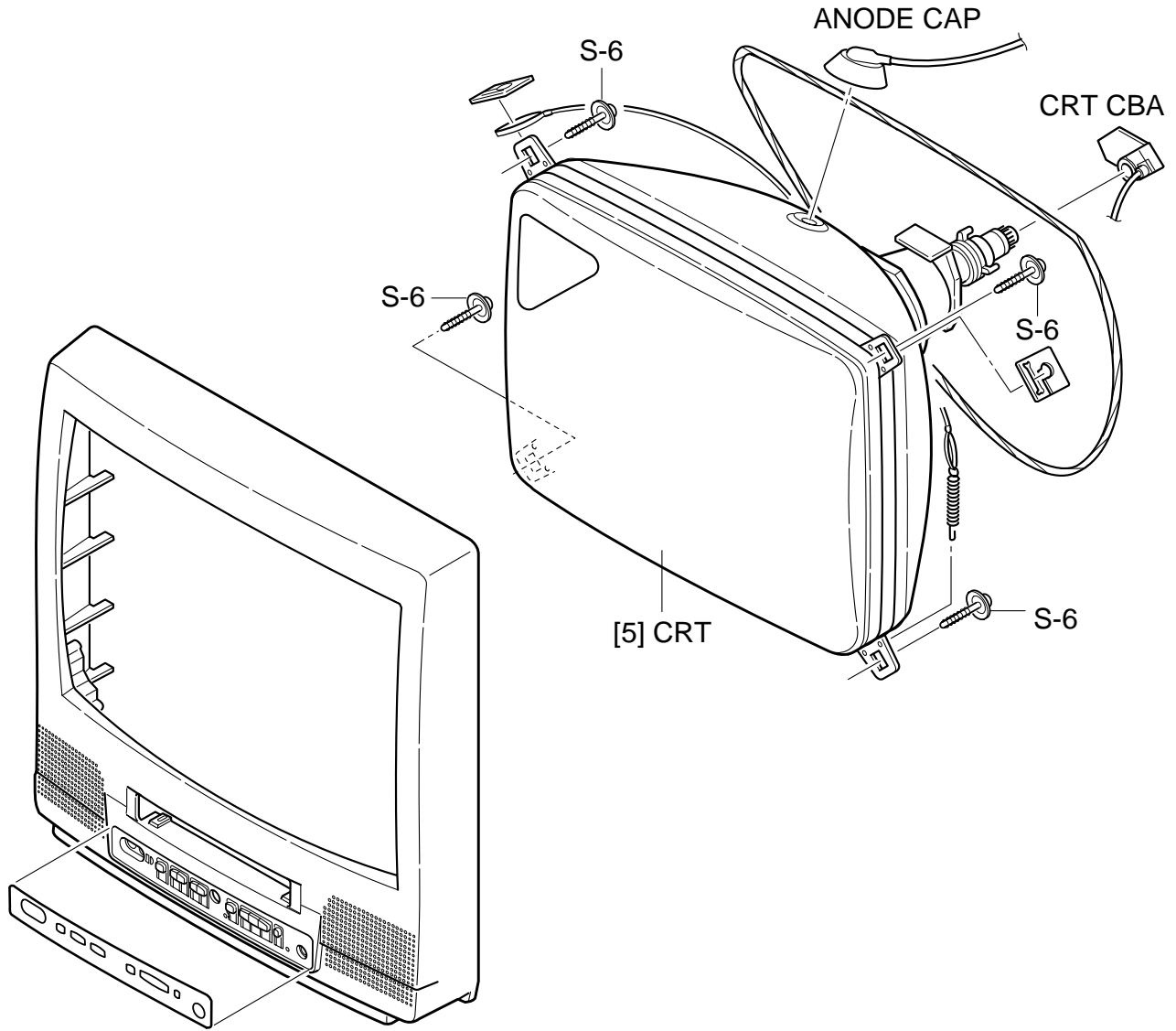


Fig. 4

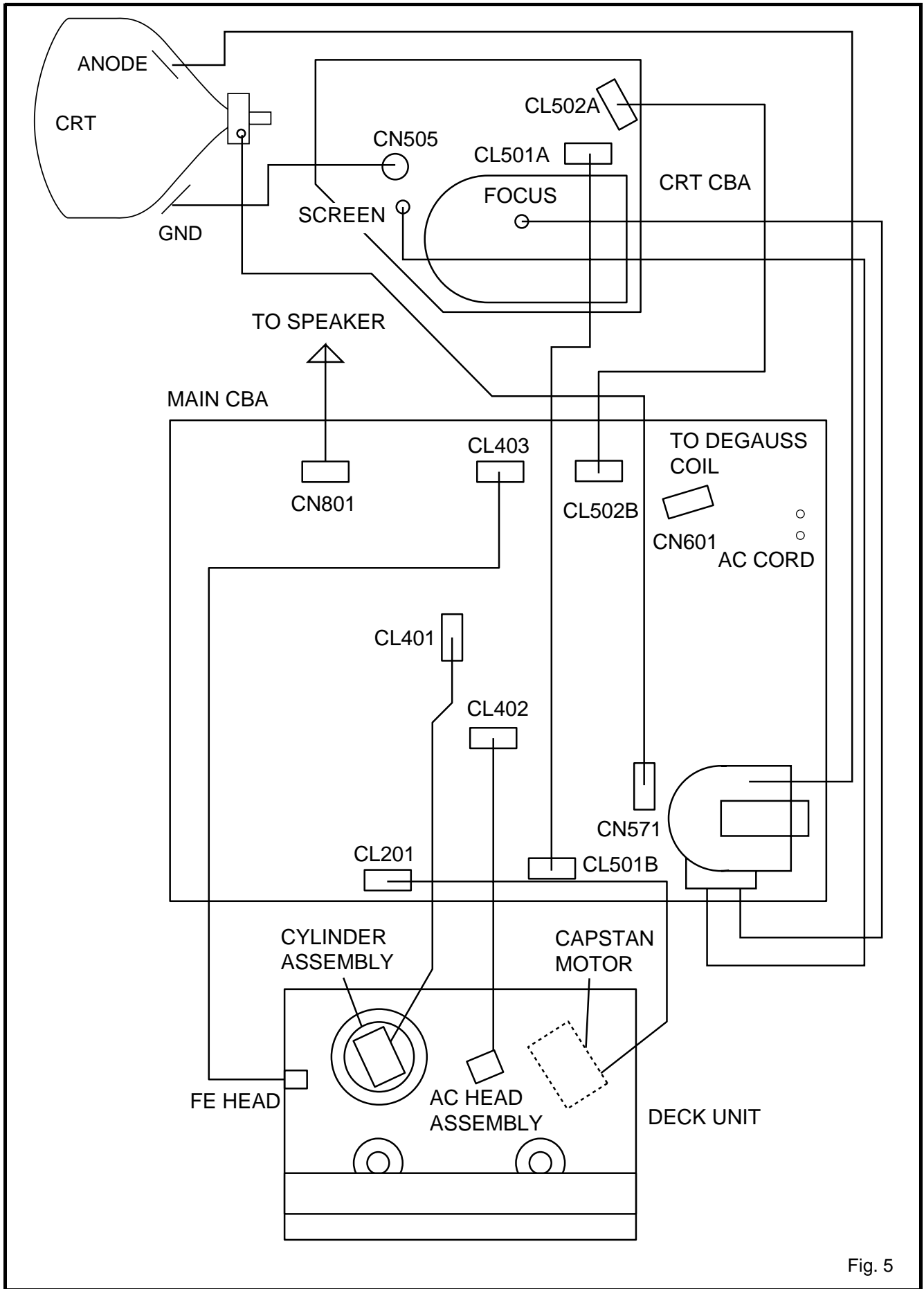


Fig. 5

# ELECTRICAL ADJUSTMENT INSTRUCTIONS

## General Note:

"CBA" is abbreviation for "Circuit Board Assembly."

## NOTE:

Electrical adjustments are required after replacing circuit components and certain mechanical parts. It is important to perform these adjustments only after all repairs and replacements have been completed.

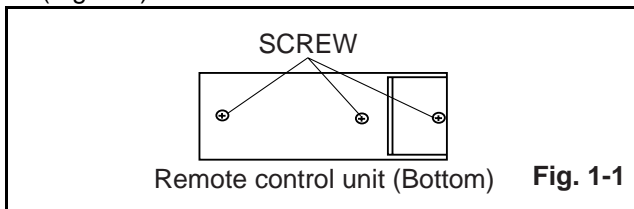
Also, do not attempt these adjustments unless the proper equipment is available.

## Test Equipment Required

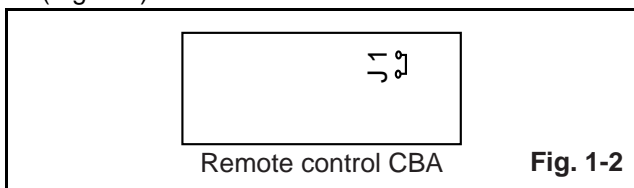
1. NTSC Pattern Generator (Color Bar W/White Window, Red Color, Dot Pattern, Gray Scale, Monoscope, Multi-Burst)
2. AC Milli Voltmeter (RMS)
3. Alignment Tape (FL8A, FL8N), Blank Tape
4. DC Voltmeter
5. Oscilloscope: Dual-trace with 10:1 probe,  
V-Range: 0.001~50V/Div,  
F-Range: DC~AC-60MHz
6. Frequency Counter
7. Plastic Tip Driver

## How to make service remote control unit:

1. Prepare remote control unit. (Part No. N0107UD or N0150UD) Remove 3 screws from the back lid. (Fig. 1-1)



2. Remote control unit: Part No. N0107UD  
Add J1 (Jumper Wire) to the remote control CBA. (Fig. 1-2)



Remote control unit: Part No. N0150UD  
Cut off pin 10 of the remote control microprocessor and short circuit pins 10 and 17 of the microprocessor with a jumper wire.

**Note:** The attached remote control unit can not be used as service remote control unit.

## How to Set up the Service mode:

### Service Mode:

1. Use the service remote control unit.
2. Turn the power on.
3. Press "WAKE-UP/SLEEP" button on the service remote control unit.

## 1. DC 114V (+B) Adjustment

**Purpose:** To obtain correct operation.

**Symptom of Misadjustment:** The picture is dark and unit does not operate correctly.

Test point	Adj. Point	Mode	Input
D613 Cathode (+B) C613(-) (GND)	VR601	---	----
Tape	M. EQ.	Spec.	
---	DC Voltmeter Plastic Tip Driver	+114±0.5V DC	

**Note:** D613 Cathode (+B), C613(-) (GND),  
VR601 --- Main CBA

1. Connect the unit to AC Power Outlet.
2. Connect DC Volt Meter to D613 Cathode (+B) and C613(-) (GND).
3. Adjust VR601 so that the voltage of D613 Cathode (+B) becomes +114±0.5V DC.

## 2-1. H Adjustment

**Purpose:** To get correct horizontal position and size of screen image.

**Symptom of Misadjustment:** Horizontal position and size of screen image may not be properly displayed.

Test point	Adj. Point	Mode	Input
R583	CH ▲ / ▼ buttons	Video	---
Tape	M. EQ.	Spec.	
---	Frequency Counter	15.734kHz±300Hz	

**Note:** R583 --- Main CBA

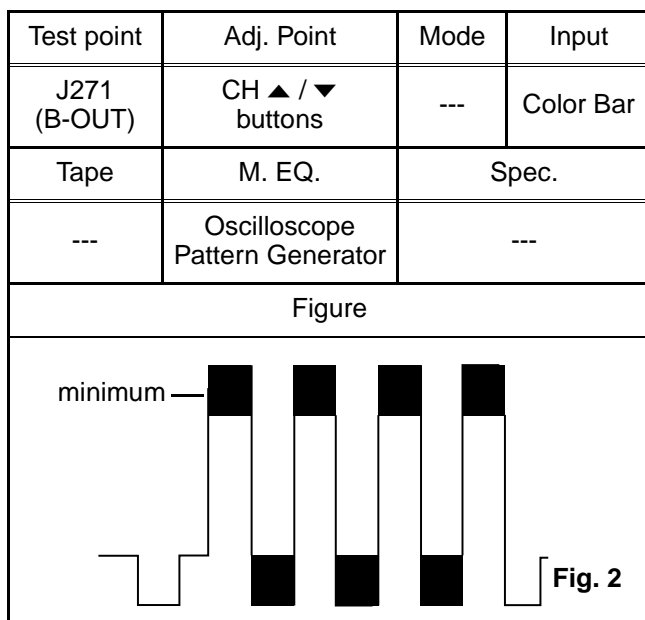
1. Connect Frequency Counter to R583.
2. Set the unit to the VIDEO mode and no input is necessary. Enter the Service mode. (See page 1-4-1.)

- Operate the unit for at least 20 minutes.
- Press "2" button on the remote control unit and select H-Adj Mode. (Press "2" button, then display will change H-Adj and AGC.)
- Press CH ▲ / ▼ buttons on the remote control unit so that the display will change "0" to "7."  
At this moment, choose display "0" to "7" when the Frequency counter display is closest to 15.734kHz±300Hz.
- Turn the power off and on again.

## 2-2. C-Trap Adjustment

**Purpose:** To get minimum leakage of the color signal carrier.

**Symptom of Misadjustment:** If C-Trap Adjustment is incorrect, stripes will appear on the screen.



**Note:** J271 (B-Out)--- Main CBA

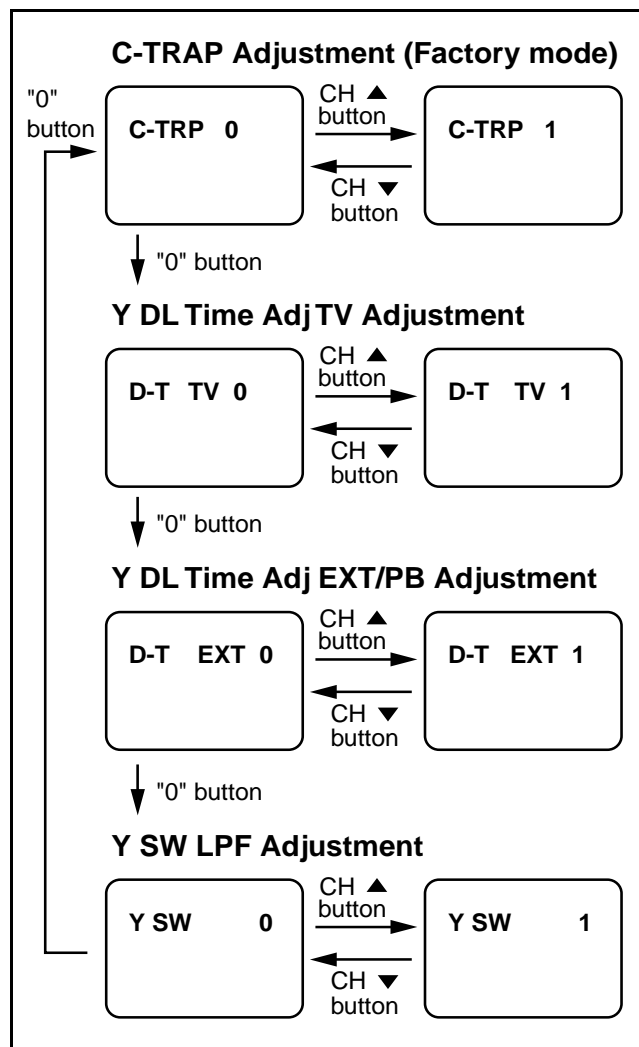
- Connect Oscilloscope to J271.
- Input a color bar signal from RF input. Enter the Service mode. (See page 1-4-1.)
- Press "0" button on the remote control unit and select C-TRAP Mode.
- Press "CH ▲ / ▼" buttons on the remote control unit so that the carrier leakage B-Out (3.58MHz) value becomes minimum on the oscilloscope.
- Turn the power off and on again.

## 2-3. Y DL Time/Y SW LPF Adjustment

**Purpose:** To get minimum leakage of the color signal carrier.

**Symptom of Misadjustment:** If Y DL Time Adjustment is incorrect, stripes will appear on the screen.

- Enter the Service Mode. (See page 1-4-1.)
- Y DL Time Adjustment:** Press "0" button on the service remote control unit twice to show "D-T" on the display.  
**Y SW LPF Adjustment:** Press "0" button on the service remote control unit four times to show "Y SW" on the display.
- Y DL Time Adjustment:** Select "2" by pressing "CH ▲ / ▼" buttons on the service remote control.
- Y SW LPF Adjustment:** Select "1" by pressing "CH ▲ / ▼" buttons on the service remote control.
- If needed, perform the following.



### 3. V. Size Adjustment

**Purpose:** To obtain correct vertical height of screen image.

**Symptom of Misadjustment:** If V. Size is incorrect, vertical height of image on the screen may not be properly displayed.

Test point	Adj. Point	Mode	Input
---	CH ▲ / ▼ buttons	---	Monoscope
Tape	M. EQ.	Spec.	
---	Pattern Generator	90±5%	

1. Enter the Service mode. (See page 1-4-1.)  
Press "9" button on the remote control unit and select V-S Mode. (Press "9" button then display will change to V-P and V-S).
2. Input monoscope pattern.
3. Press "CH ▲ / ▼" buttons on the remote control unit so that the monoscope pattern is 90±5% of display size and the circle is round.

### 4. V. Shift Adjustment

**Purpose:** To obtain correct vertical position of screen image.

**Symptom of Misadjustment:** If V. position is incorrect, vertical position of image on the screen may not be properly displayed.

Test point	Adj. Point	Mode	Input
---	CH ▲ / ▼ buttons	---	Monoscope
Tape	M. EQ.	Spec.	
---	Pattern Generator	90±5%	

1. Enter the Service mode. (See page 1-4-1.)  
Press "9" button on the remote control unit and select V-P Mode. (Press "9" button then display will change to V-P and V-S).
2. Input monoscope pattern.
3. Press "CH ▲ / ▼" buttons on the remote control unit so that the top and bottom of the monoscope pattern are equal to each other.

### 5. H. Shift Adjustment

**Purpose:** To obtain correct horizontal position and size of screen image.

**Symptom of Misadjustment:** Horizontal position and size of screen image may not be properly displayed.

Test point	Adj. Point	Mode	Input
---	CH ▲ / ▼ buttons	---	Monoscope
Tape	M. EQ.	Spec.	
---	Pattern Generator	90±5%	

1. Enter the Service mode. (See page 1-4-1.)  
Press "8" button on the remote control unit and select H-P Mode.
2. Input monoscope pattern.
3. Press "CH ▲ / ▼" buttons on the remote control unit so that the left and right side of the monoscope pattern are equal to each other.
4. Turn the power off and on again.

### 6. Cut-off Adjustment

**Purpose:** To adjust the beam current of R, G, B, and screen voltage.

**Symptom of Misadjustment:** White color may be reddish, greenish or bluish.

Test point	Adj. Point	Mode	Input
---	Screen-Control	Ext.	Black Raster / White Raster
Tape	M. EQ.	Spec.	
---	Pattern Generator	See Reference Notes below	

Figure

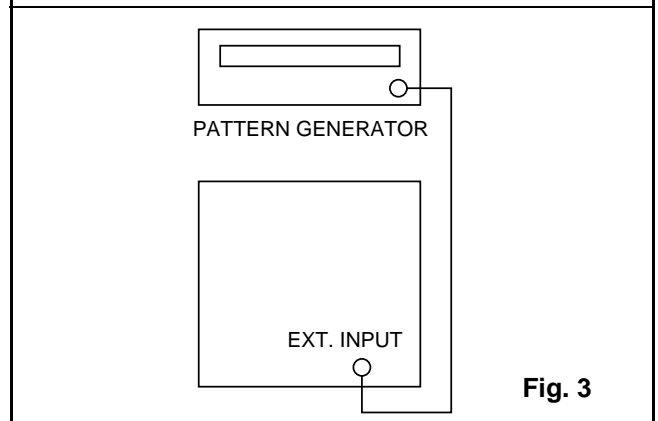


Fig. 3



**Notes:** Screen Control FBT --- MAIN CBA  
 F.B.T= Fly Back Transformer  
 Use the Remote Control Unit

1. Degauss the CRT and allow CRT to operate for 20 minutes before starting the alignment.
2. Set the screen control to minimum position. Input the Black raster signal from RF input.
3. Enter the Service Mode. (See page 1-4-1.) Dimmed horizontal line appears on the CRT.
4. Press the "VOL ▼" button once.
5. Press "1" button. This adjustment mode is CUT OFF (R).
6. Press the "CH ▲ / ▼" button until the horizontal line becomes white.
7. Press "2" button. This adjustment mode is CUT OFF (G). Press "CH ▲ / ▼" until the horizontal line becomes white.
8. Press "3" button. This adjustment mode is CUT OFF (B). Press "CH ▲ / ▼" until the horizontal line becomes white.
9. Input the White Raster Signal from Video In.
10. Press "4" button. Adjust the RED DRIVE as needed with the "CH ▲ / ▼" buttons to get the following value, X= 286, Y= 294.
11. Press "5" button. Adjust the BLUE DRIVE as needed with the "CH ▲ / ▼" buttons to get the following value, X= 286.
12. Turn the power off and on again.

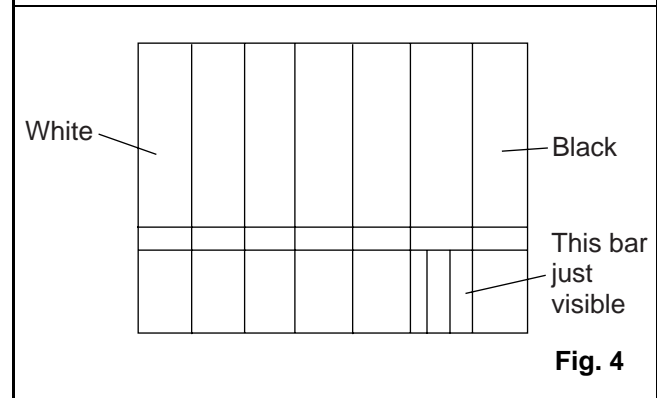
## 7. Sub-Brightness Adjustment

**Purpose:** To get proper brightness.

**Symptom of Misadjustment:** If Sub-Brightness is incorrect, proper brightness cannot be obtained by adjusting the Brightness Control.

Test point	Adj. Point	Mode	Input
---	CH ▲ / ▼ buttons	---	SYMPTE 7.5IRE
Tape	M. EQ.	Spec.	
---	Pattern Generator	See below	

Figure



**Note:** SYMPTE Setup level --- 7 IRE

1. Enter the Service Mode. (See page 1-4-1.) Then input SYMPTE signal from RF input.
2. Press "MENU" button. (Press "MENU" button then display will change B R T, C N T, C O L, T N T, V-T and SHP). Select BRT and press "CH ▲ / ▼" buttons so that the bar is just visible (See above figure).
3. Turn the power off and on again.

## 8. Focus Adjustment

**Purpose:** Set the optimum Focus.

**Symptom of Misadjustment:** If Focus Adjustment is incorrect, blurred images are shown on the display.

Test point	Adj. Point	Mode	Input
---	Focus Control	---	Monoscope
Tape	M. EQ.	Spec.	
---	Pattern Generator	See below.	

**Note:** Focus VR (FBT) --- MAIN CBA

FBT= Fly Back Transformer

1. Operate the unit more than 30 minutes.
2. Face the unit to the East and degauss the CRT using a Degaussing Coil.
3. Input the monoscope pattern.
4. Adjust the Focus Control on the FBT to obtain clear picture.

## 9. Head Switching Position Adjustment

**Purpose:** Determine the Head Switching Point during Playback.

**Symptom of Misadjustment:** May cause Head Switching Noise or Vertical Jitter in the picture.

**Note:** Unit reads Head Switching Position automatically and displays it on the screen (Upper Left Corner).

1. Playback test tape (FL8A, FL8N).
2. Enter the Service Mode. (See page 1-4-1.) Then press the "5" button on the remote control unit.
3. The Head Switching position will display on the screen; if adjustment is necessary follow step 4. 6.5H(412.7μs) is preferable.
4. Press "CH ▲" or "CH ▼" button on the remote control unit if necessary. The value will be changed in 0.5H steps up or down. Adjustable range is up to 9.5H. If the value is beyond adjustable range, the display will change as:  
Lower out of range: 0.0H  
Upper out of range: --H
5. Turn the power off and on again.

## 10. CCS Text Box Location

When replacing the CRT, the CCS Box might not stay in appropriate position. Then, replace micro computer.

**Note:** This adjustment automatically done by the microcomputer.

The following 2 adjustments normally are not attempted in the field. They should be done only when replacing the CRT then adjust as a preparation.

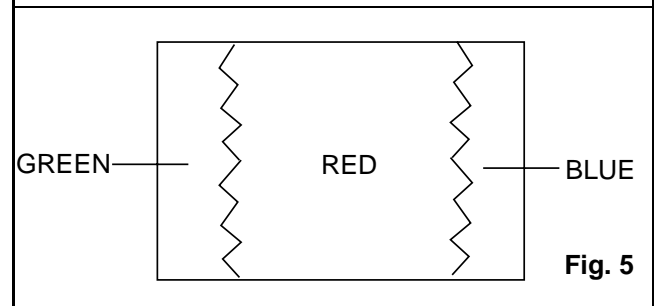
## 11. Purity Adjustment

**Purpose:** To obtain pure color.

**Symptom of Misadjustment:** If Color Purity Adjustment is incorrect, large areas of color may not be properly displayed.

Test point	Adj. Point	Mode	Input
---	Deflection Yoke Purity Magnet	---	*Red Color
Tape	M. EQ.	Spec.	
---	Pattern Generator	See below.	

Figure



\* This becomes RED COLOR if push 7KEY with a service mode.

1. Set the unit facing east.
2. Operate the unit for over 30 minutes before adjusting.
3. Fully degauss the unit using an external degaussing coil.
4. Set the unit to the AUX Mode which is located before CH2 then input a red raster from video in.
5. Loosen the screw on the Deflection Yoke Clamper and pull the Deflection Yoke back away from the screen. (See Fig. 6.)
6. Loosen the Ring Lock and adjust the Purity Magnets so that a red field is obtained at the center of the screen. Tighten Ring Lock. (See Fig. 5,6.)
7. Slowly push the Deflection Yoke toward the bell of the CRT and set it where a uniform red field is obtained.
8. Tighten the clamp screw on the Deflection Yoke.

## 12. Convergence Adjustment

**Purpose:** To obtain proper convergence of red, green and blue beams.

**Symptom of Misadjustment:** If Convergence Adjustment is incorrect, the edge of white letters may have color edges.

Test point	Adj. Point	Mode	Input
---	C.P. Magnet (RB), C.P. Magnet (RB-G), Deflection Yoke	---	Dot Pattern or Crosshatch
Tape	M. EQ.	Spec.	
---	Pattern Generator	See below.	

Figure

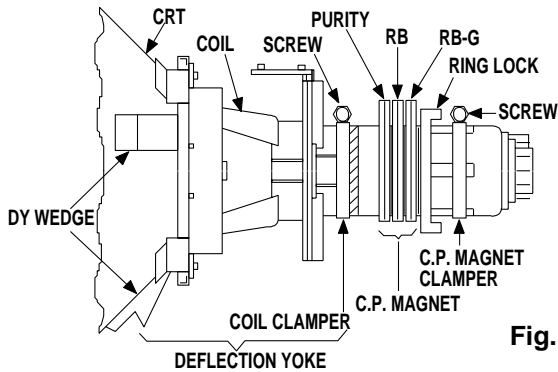


Fig. 6

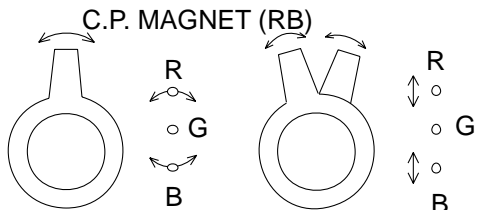


Fig. 7

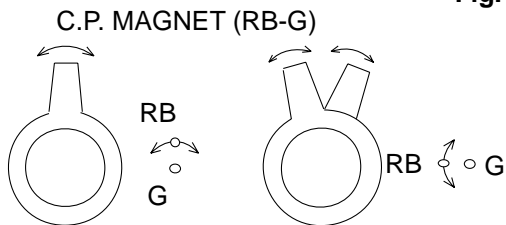
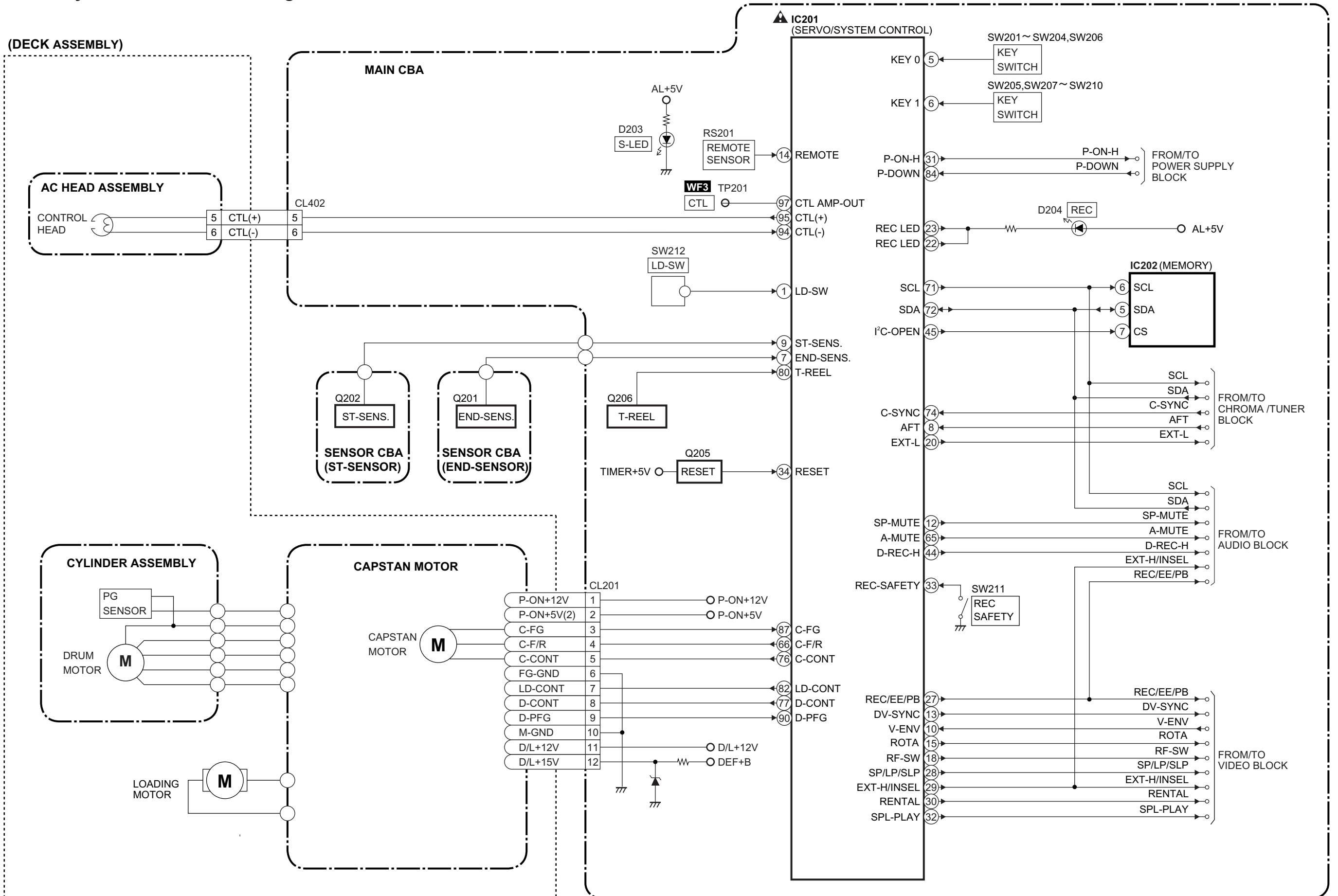


Fig. 8

1. Set the unit to the AUX Mode which is located before CH2 then input a Dot or crosshatch pattern.
2. Loosen the Ring Lock and align red with blue dots or Crosshatch at the center of the screen by rotating (RB) C.P. Magnets. (See Fig. 7.)
3. Align red / blue with green dots at the center of the screen by rotating (RB-G) C.P. Magnet. (See Fig. 8.)
4. Fix the C.P. Magnets by tightening the Ring Lock.
5. Remove the DY Wedges and slightly tilt the Deflection Yoke horizontally and vertically to obtain the best overall convergence.
6. Fix the Deflection Yoke by carefully inserting the DY Wedges between CRT and Deflection Yoke.

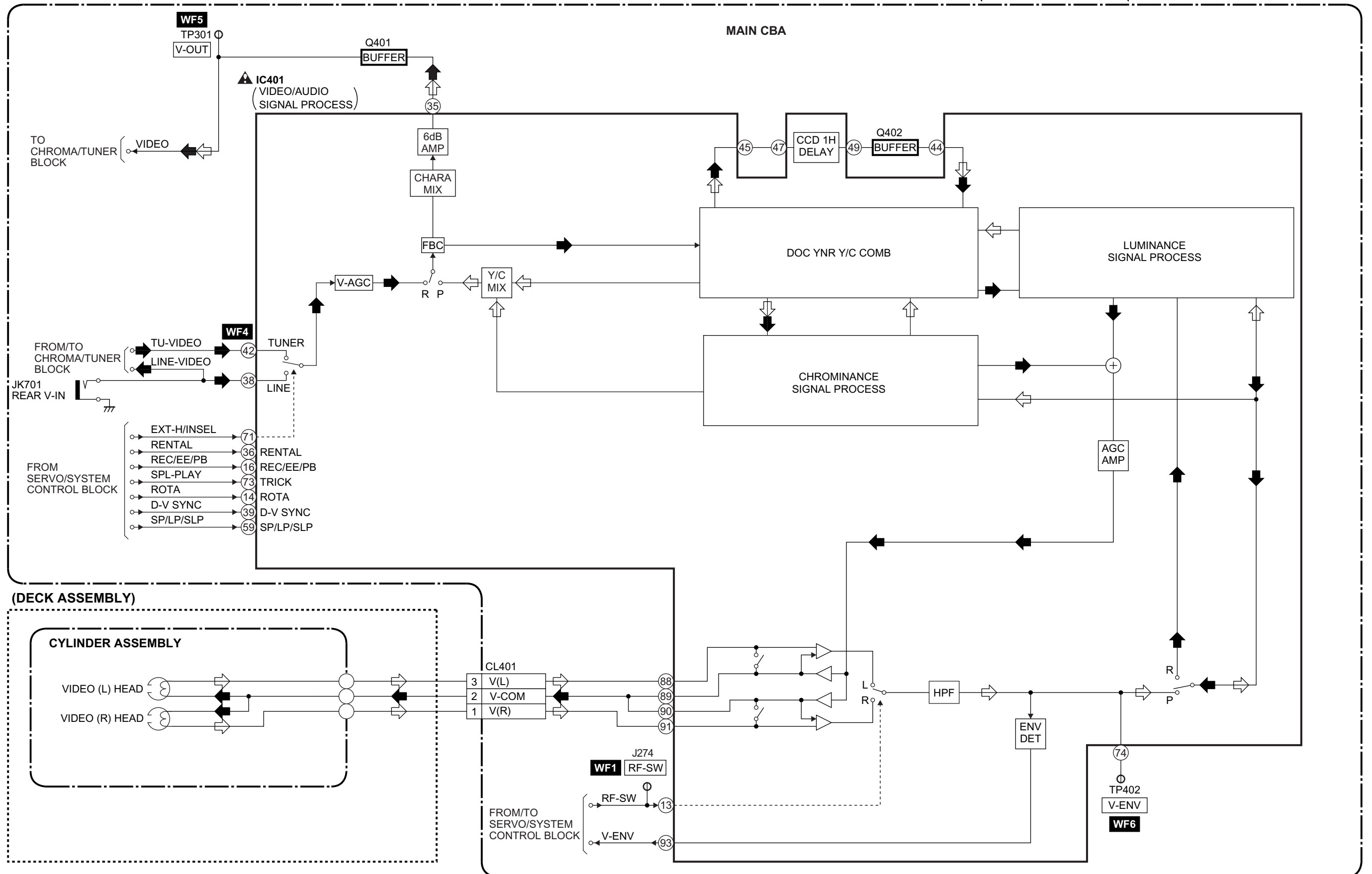
# BLOCK DIAGRAMS

## Servo/System Control Block Diagram



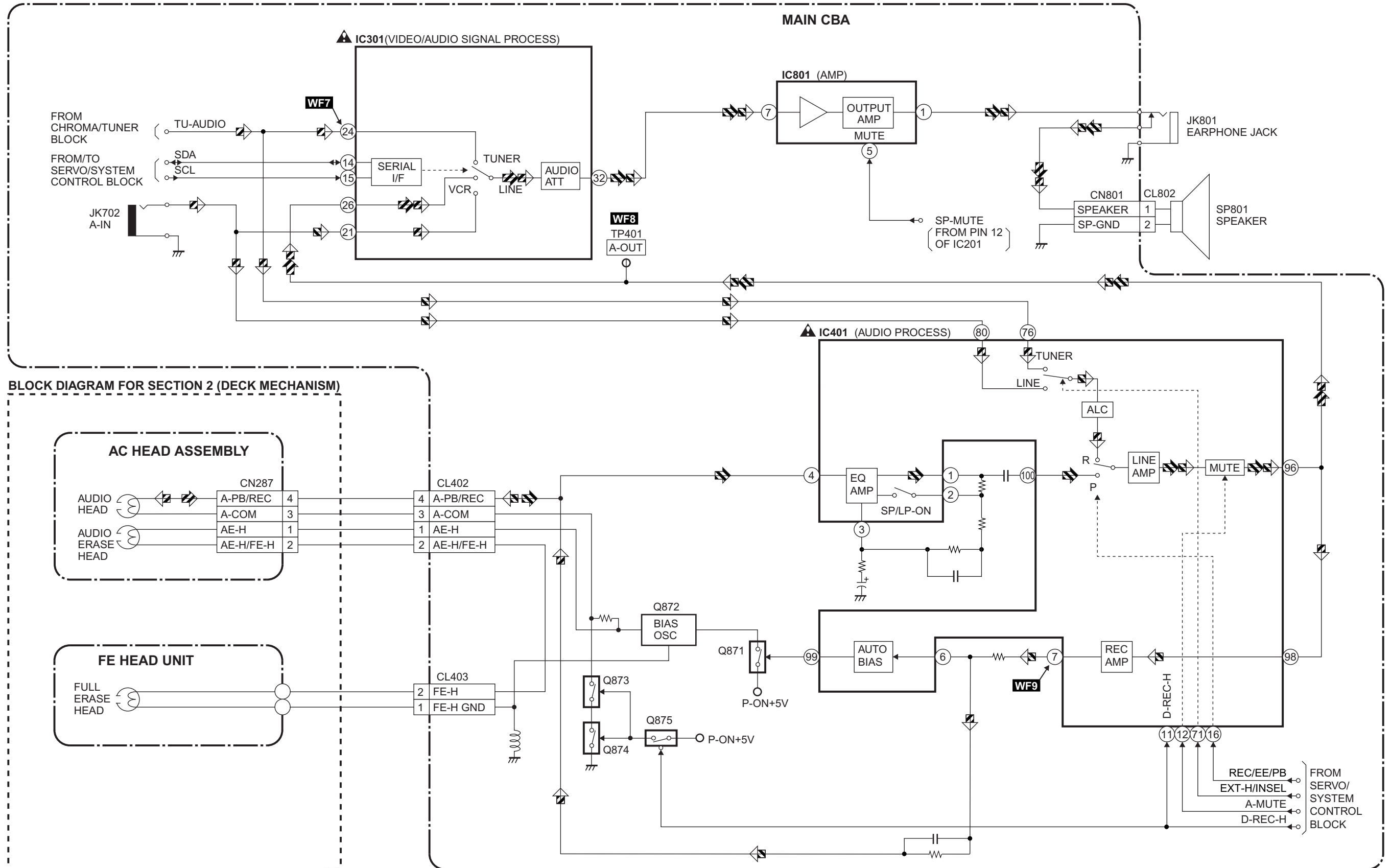
# Video Block Diagram

← REC VIDEO SIGNAL   ← PB VIDEO SIGNAL   MODE: SP/REC

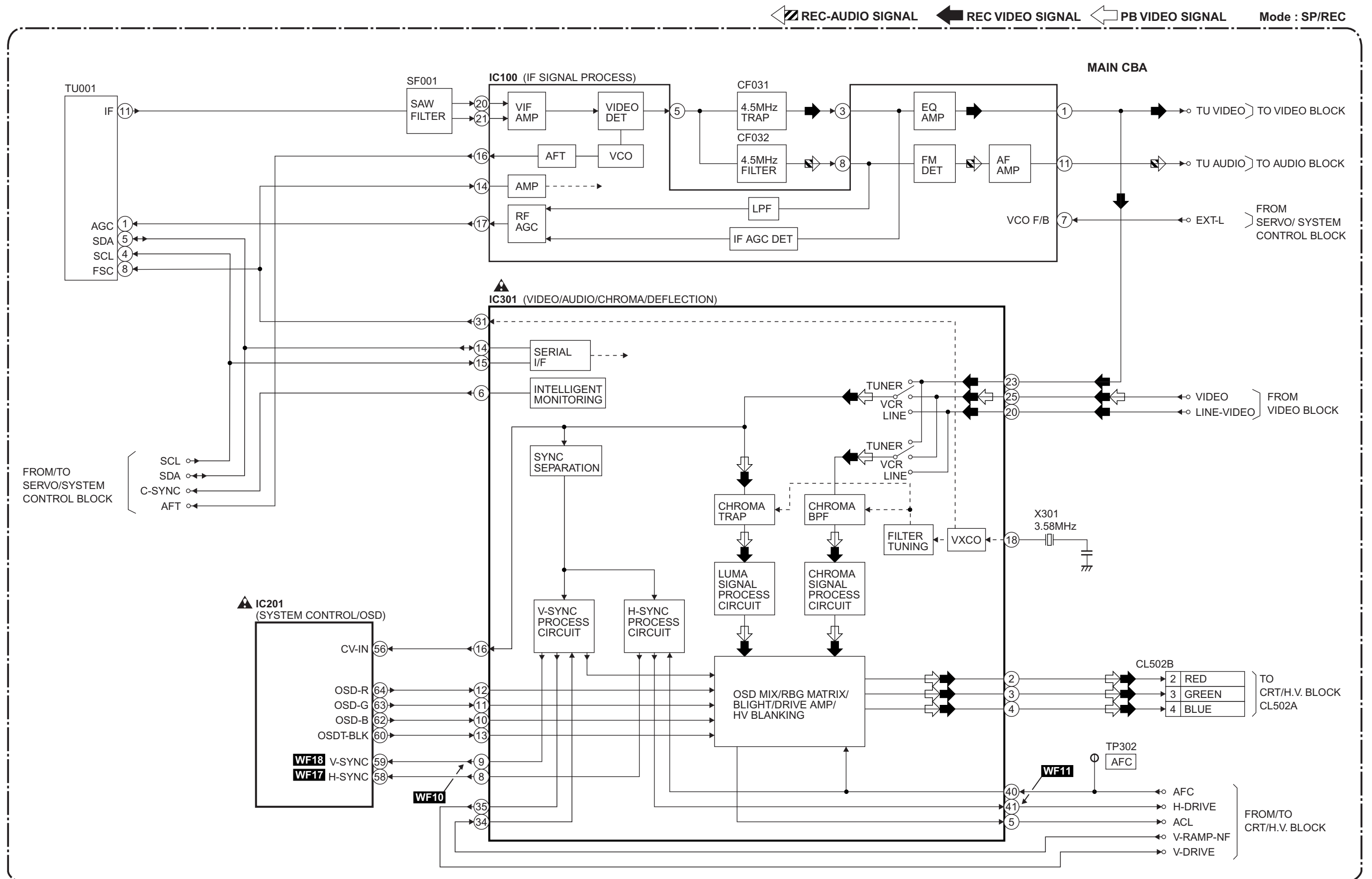


# Audio Block Diagram

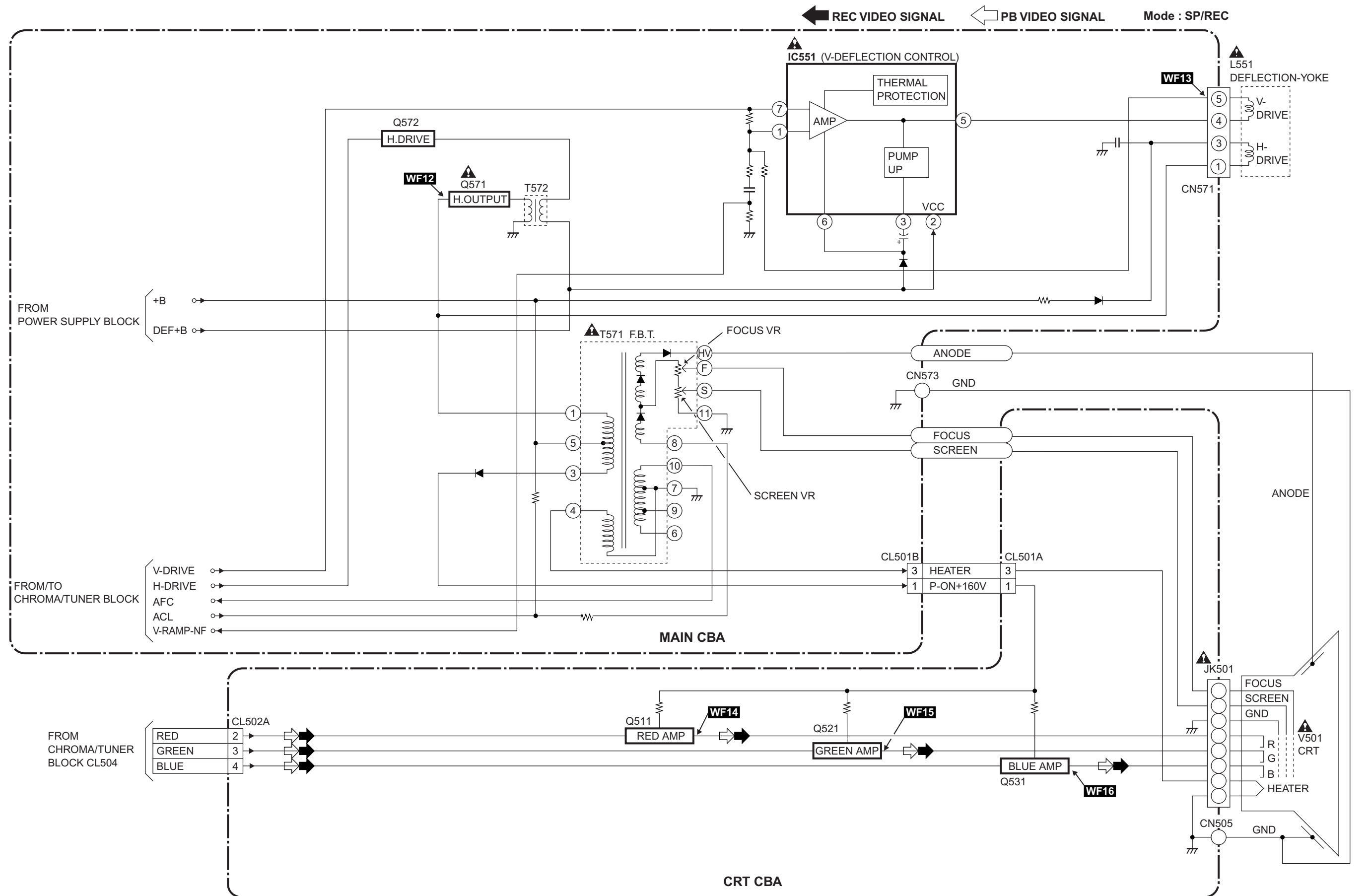
 PB-AUDIO SIGNAL  
  REC-AUDIO SIGNAL  
 Mode : SP/REC



# Chroma/Tuner Block Diagram



# CRT/H.V. Block Diagram

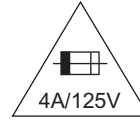




# Power Supply Block Diagram

## CAUTION !

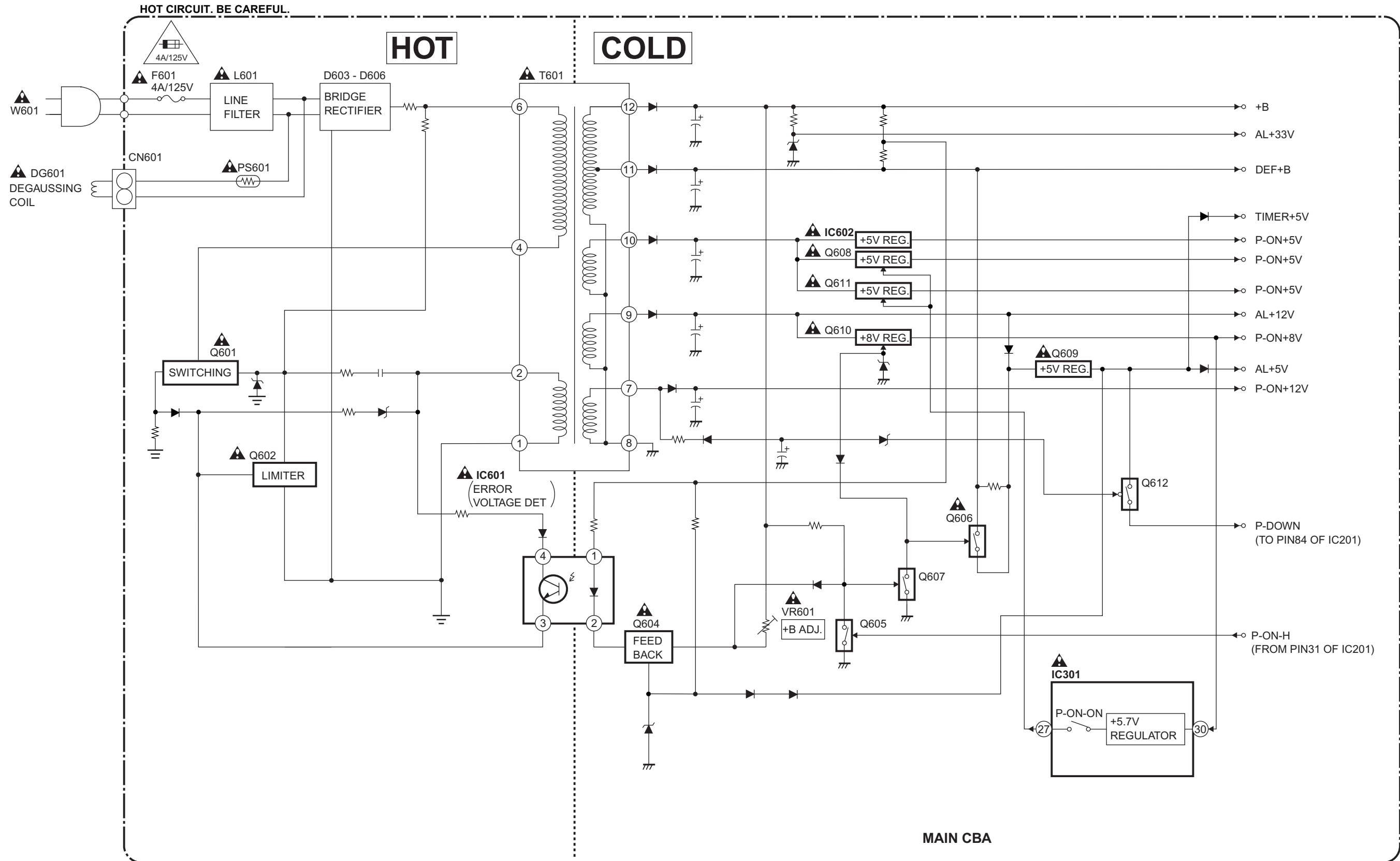
Fixed voltage ( or Auto voltage selectable ) power supply circuit is used in this unit.  
 If Main Fuse (F601) is blown, check to see that all components in the power supply circuit are not defective before you connect the AC plug to the AC power supply.  
 Otherwise it may cause some components in the power supply circuit to fail.



**CAUTION:** FOR CONTINUED PROTECTION AGAINST RISK OF FIRE,  
 REPLACE ONLY WITH SAME TYPE 4 A, 125V FUSE.  
**ATTENTION:** UTILISER UN FUSIBLE DE RECHANGE DE MÊME TYPE DE 4A, 125V.

## NOTE :

The voltage for parts in hot circuit is measured using hot GND as a common terminal.



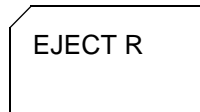
# MECHANICAL TROUBLE INDICATOR

## 1, Each Malfunction Indication

If the MONITOR is turned ON right after the Mechanical Malfunction occurs or POWER SAFETY/X-RAY is turned ON, display the following character to show Malfunction after the EJECT display.

Immediately preceding Malfunction	Display character
REEL Malfunction	R
DRUM Malfunction	D
CASSETTE LOADING Malfunction	C
TAPE LOADING Malfunction	T
P-SAFETY 2	2
P-SAFETY 3	3
X-RAY	X

Example: If REEL Malfunction



## 2, Each Malfunction evaluation method

### X-RAY protect

If X-RAY port becomes continuously 2.5V or more for 120 msec. (4 times 40 msec. interval), the unit shall immediately turn OFF the POWER/MONITOR and switch over to the Mechanical Malfunction mode with POWER OFF.

(To return from this mode shall become possible only by POWER Key as in the case of the Mechanical Malfunction).

## POWER SAFETY

### 1) POWER SAFETY 2

If P-SAFETY 2 port becomes continuously 2.5V or less for 120 msec. (4 times 40 msec. interval) when P-ON-H port is ON, the unit shall be assumed to be the Power Malfunction 2 and immediately turn OFF the POWER/MONITOR and switch over the Mechanical Malfunction mode with POWER OFF.

(Shall not unload)

(To return from this mode shall become possible only by POWER Key as in the case of the Mechanical Malfunction).

\* However the POWER SAFETY 2 function shall be disabled during 500 msec. right after the P-ON-H turns ON.

### 2) POWER SAFETY 3

If P-SAFETY 3 port becomes continuously 2.5V or over for 120 msec. (4 times 40 msec. interval) when MONITOR is ON, P-SAFETY 3 function is available. After that, if P-SAFETY 3 port becomes continuously 2.5V or less for 120 msec. (4 times 40 msec. interval), the unit shall be assumed to be the Power Malfunction 3 and immediately turn OFF the POWER/MONITOR and switch over the Mechanical Malfunction mode with POWER OFF.

(Shall not unload)

(To return from this mode shall become possible only by POWER Key as in the case of the Mechanical Malfunction).

## Mechanical Malfunction determination

### 1) REEL Malfunction detection

Countermeasure for REEL and CAPSTAN motor rotation malfunction (Except CASSETTE LOADING function)

After the Malfunction detection with REEL/CAPSTAN sensor, the unit shall switch over to STOP (B) and be REEL Mechanical Malfunction.

- a) If the T-REEL pulse is not impressed after a lapse of 5 sec. at SP, 10 sec. at LP, 14 sec. at SLP, or more in the REEL Rotation Mode like PLAY/REC, FS/RS Mode, and the T-REEL or S-REEL pulse is not impress after a lapse of 4 sec. or more in REEL Rotation Mode of FF/REW, it shall be assumed to stop the rotation and switch over to STOP (B) position, then POWER be turned OFF and the unit be REEL Mechanical Malfunction. (T-REEL and S-REEL for the models on S-REEL and only T-REEL for other models)
- b) If the C-FG pulse is not impressed for a lapse of 1 sec. or more during the CAPSTAN MOTOR rotation, it shall be MOTOR Rotation Malfunction (REEL Malfunction).

### 2) DRUM Malfunction detection

Detect the DRUM rotation at the D-FG input terminal.

If the variation of D-FG input level is not detected for a lapse of 1 sec. or more when D-CONT is "H", it shall be assumed to be Rotation Malfunction and be DRUM Malfunction.

When detect Drum Malfunction, POWER shall be turned OFF after the unit switches over to STOP (B) Mode.

### 3) Countermeasure for TAPE LOADING Malfunction

Detect the Malfunction with the LOADING Switch.

#### a) TAPE LOADING Malfunction

If LD-SW does not go to the established position after a lapse of 7 sec. or more from TAPE LOADING or TAPE UNLOADING start, the LOADING function shall immediately be stopped and POWER be turned OFF, and inform the Timer about the LOADING Mechanical Malfunction.

#### b) LD-SW Position Malfunction at each mode

When the unit operates at each mode, even if the LD-SW position changes from the established one in its mode, it keeps the function according to its mode.

#### 4) Countermeasure for CASSETTE LOADING Malfunction

##### a) CASSETTE IN operating Malfunction

If LD-SW does not go to SB position after a lapse of 5 sec. or more from the CASSETTE insertion start, the unit starts the CASSETTE OUT operation.

After switch over to CASSETTE OUT operation and then a laps of 5 sec. or more from the CASSETTE OUT operation start, if LD-SW does not go to the EJ position or if START Sensor and END Sensor does not turn "ON" at the EJ position, the unit starts again to insert CASSETTE.

(However in S-INH state, the START/END Sensor shall be disabled).

##### b) CASSETTE OUT operating Malfunction

After a lapse of 5 sec. or more from CASSETTE OUT operation start, if LD-SW does not go to the EJ position or if START Sensor and END Sensor does not turn "ON" at the EJ position, the unit starts to insert CASSETTE.

(However in S-INH state, the START/END Sensor shall be disabled).



When the unit switches over to CASSETTE insertion at CASSETTE IN or CASSETTE OUT Malfunction, if LD-SW does not go to the SB position after a lapse of 5 sec. or more from CASSETTE insertion start, the function shall immediately be stopped and POWER be turned OFF, and the unit be CASSETTE LOADING Malfunction.

##### c) When POWER is turned ON, if the CL position or GC position cannot be detected after 5 sec. LD-REV operation and 5 sec. LD-FWD operation, the function shall immediately be stopped and POWER be turned OFF, and the unit be CASSETTE LOADING Malfunction.

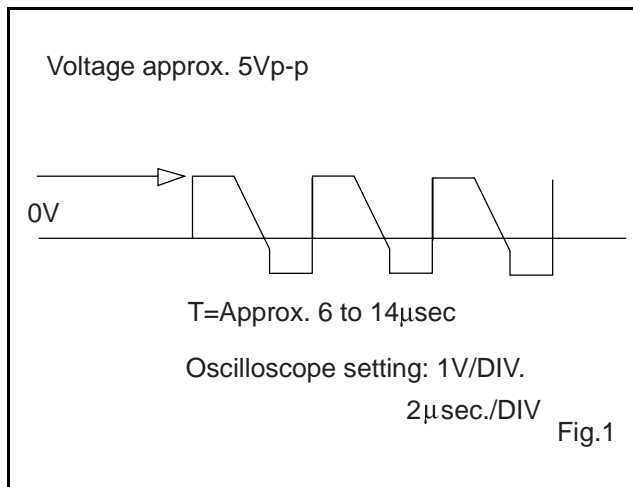
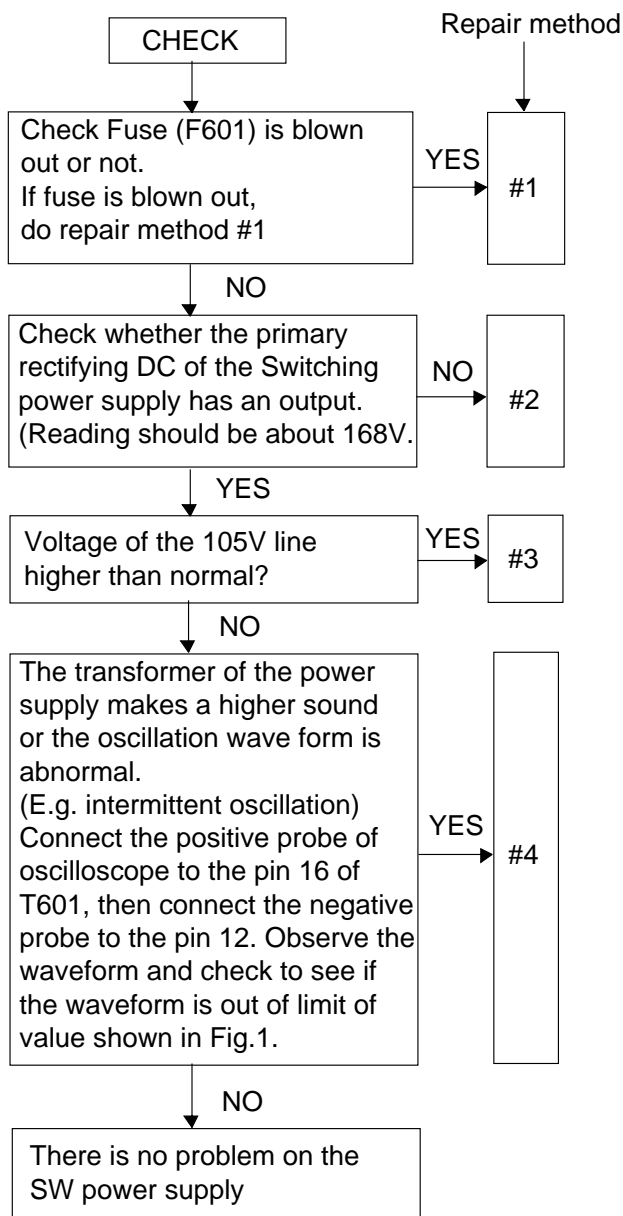
##### d) When POWER is turned ON without CASSETTE (EJ position) and LD-SW is monitored all the time, if the CL or GC position is detected continuously for 1 sec. or more, the POWER shall be turned OFF and the unit be CASSETTE LOADING Malfunction.

## Countermeasure for Mechanical Malfunction

If the unit detects Mechanical Malfunction, turn the POWER OFF. If the unit is Mechanical Malfunction, Key input except POWER key shall be disabled and CASSETTE insertion disabled. When POWER Key is entered, the POWER is turned ON and the unit switches over the EJECT Mode. (Return with POWER ON)

# Power Supply Trouble Shooting Guide

It is highly recommended that a variable isolation transformer which can monitor current be used. (Alternatively a variable AC source which monitors current will do). Read directions below before power is added!



## Repair method #1

(Power must be off)

Short circuit in the secondary side. check diode D613, D614, D616, D617 and D618, switching transistor (Q601), control transistor (Q602), diode and resistor replace as necessary.

Disconnect 105V diode (D613), 25V diode (D614), 8V diode (D616), 12V diode (D617), 12V diode (D618) and Check the load continuity of 105V line, 25V line, 8V line, 12V line through a tester (resistance range).

If the tester indicates a lower resistance value around 0 ohm, the line is short-circuited.

Before repairing the switching power supply, find out the short-circuited area of such line and repair it.

If the tester does not indicate any low resistance value (around 0 ohm), no load is short-circuited and there is no problem.

Check for any defective parts while the secondary rectifying diodes are disconnected (D613, D614, D616, D617 and D618) perform a diode check in both forward and reverse directions through a tester.

## **Repair method #2**

Check the primary rectifying diodes (D603-D606) as possible problems. Remove the above mentioned parts and check them. Perform check according to the step 1 and 2 of repair method #1 and check for defects following parts, then if necessary replace with factory originals.

R602 is open or not.

Q601, Q602, D607, D608 and D611 are short or not.

## **Repair method #3**

The feedback circuit which is monitored by the output of D613 105V may not work and this may be regarded as a possible cause, remove IC601 (Photo Coupler), diode (D620) and transistor (Q604) check for defects.

## **Repair method #4**

Check control circuitry which is connecting to Pin 2 and 1 of Switching Transformer T601.

# SCHEMATIC DIAGRAMS / CBA'S AND TEST POINTS

## Standard Notes

### Warning

Many electrical and mechanical parts in this chassis have special characteristics. These characteristics often pass unnoticed and the protection afforded by them cannot necessarily be obtained by using replacement components rated for higher voltage, wattage, etc. Replacement parts that have these special safety characteristics are identified in this manual and its supplements; electrical components having such features are identified by the mark "▲" in the schematic diagram and the parts list. Before replacing any of these components, read the parts list in this manual carefully. The use of substitute replacement parts that do not have the same safety characteristics as specified in the parts list may create shock, fire, or other hazards.

### Note:

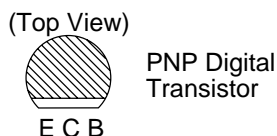
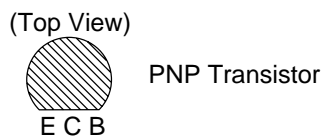
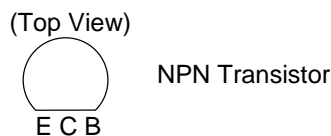
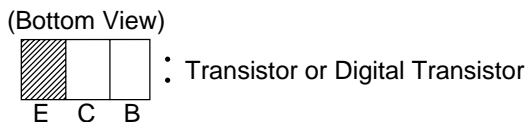
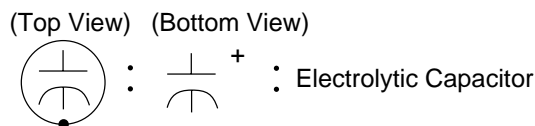
1. Do not use the part number shown on these drawings for ordering. The correct part number is shown in the parts list, and may be slightly different or amended since these drawings were prepared.
2. All resistance values are indicated in ohms ( $K=10^3$ ,  $M=10^6$ ).
3. Resistor wattages are 1/4W or 1/6W unless otherwise specified.
4. All capacitance values are indicated in  $\mu F$  ( $P=10^{-6}\mu F$ ).
5. All voltages are DC voltages unless otherwise specified.

## Capacitor Temperature Markings

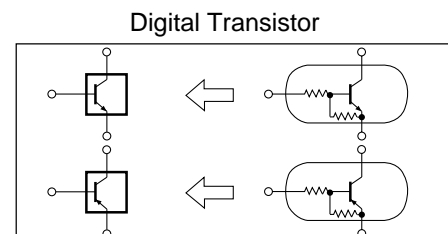
Mark	Capacity change rate	Standard temperature	Temperature range
(B)	$\pm 10\%$	20°C	-25~+85°C
(F)	+30 -80%	20°C	-25~+85°C
(SR)	$\pm 15\%$	20°C	-25~+85°C
(Z)	+30 -80%	20°C	-10~+70°C

Capacitors and transistors are represented by the following symbols.

### CBA Symbols



### Schematic Diagram Symbols



## LIST OF CAUTION, NOTES, AND SYMBOLS USED IN THE SCHEMATIC DIAGRAMS ON THE FOLLOWING PAGES:

1. **CAUTION:** FOR CONTINUED PROTECTION AGAINST RISK OF FIRE, REPLACE ONLY WITH SAME TYPE\_A,\_V FUSE.

**ATTENTION:** UTILISER UN FUSIBLE DE RECHANGE DE MÊME TYPE DE\_A,\_V.

### 2. CAUTION:

Fixed Voltage (or Auto voltage selectable) power supply circuit is used in this unit.

If Main Fuse (F601) is blown, first check to see that all components in the power supply circuit are not defective before you connect the AC plug to the AC power supply. Otherwise it may cause some components in the power supply circuit to fail.

### 3. Note:

(1) Do not use the part number shown on the drawings for ordering. The correct part number is shown in the parts list, and may be slightly different or amended since the drawings were prepared.

(2) To maintain original function and reliability of repaired units, use only original replacement parts which are listed with their part numbers in the parts list section of the service manual.

### 4. Wire Connectors

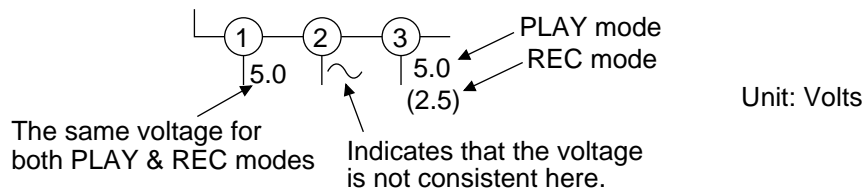
(1) Prefix symbol "CN" means "connector" (can disconnect and reconnect).

(2) Prefix symbol "CL" means "wire-solder holes of the PCB" (wire is soldered directly).

5. Note: Mark "•" is a leadless (chip) component.

6. Mode: SP/REC

7. Voltage indications for PLAY and REC modes on the schematics are as shown below:

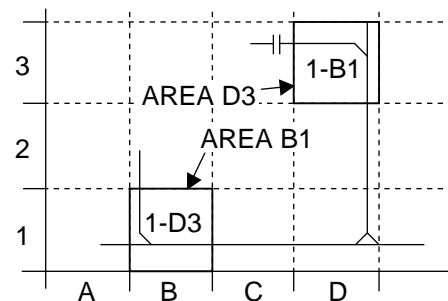


### 8. How to read converged lines

1-D3  
↑  
Distinction Area  
Line Number  
(1 to 3 digits)

Examples:

- "1-D3" means that line number "1" goes to area "D3".
- "1-B1" means that line number "1" goes to area "B1".



### 9. Test Point Information

⊙ : Indicates a test point with a jumper wire across a hole in the PCB.

□→ : Used to indicate a test point with a component lead on foil side.

⊘ : Used to indicate a test point with no test pin.

● : Used to indicate a test point with a test pin.

A4

B4

C4

D4

E4

F4

A3

B3

C3

D3

E3

F3

A2

B2

C2

D2

E2

F2

A1

B1

C1

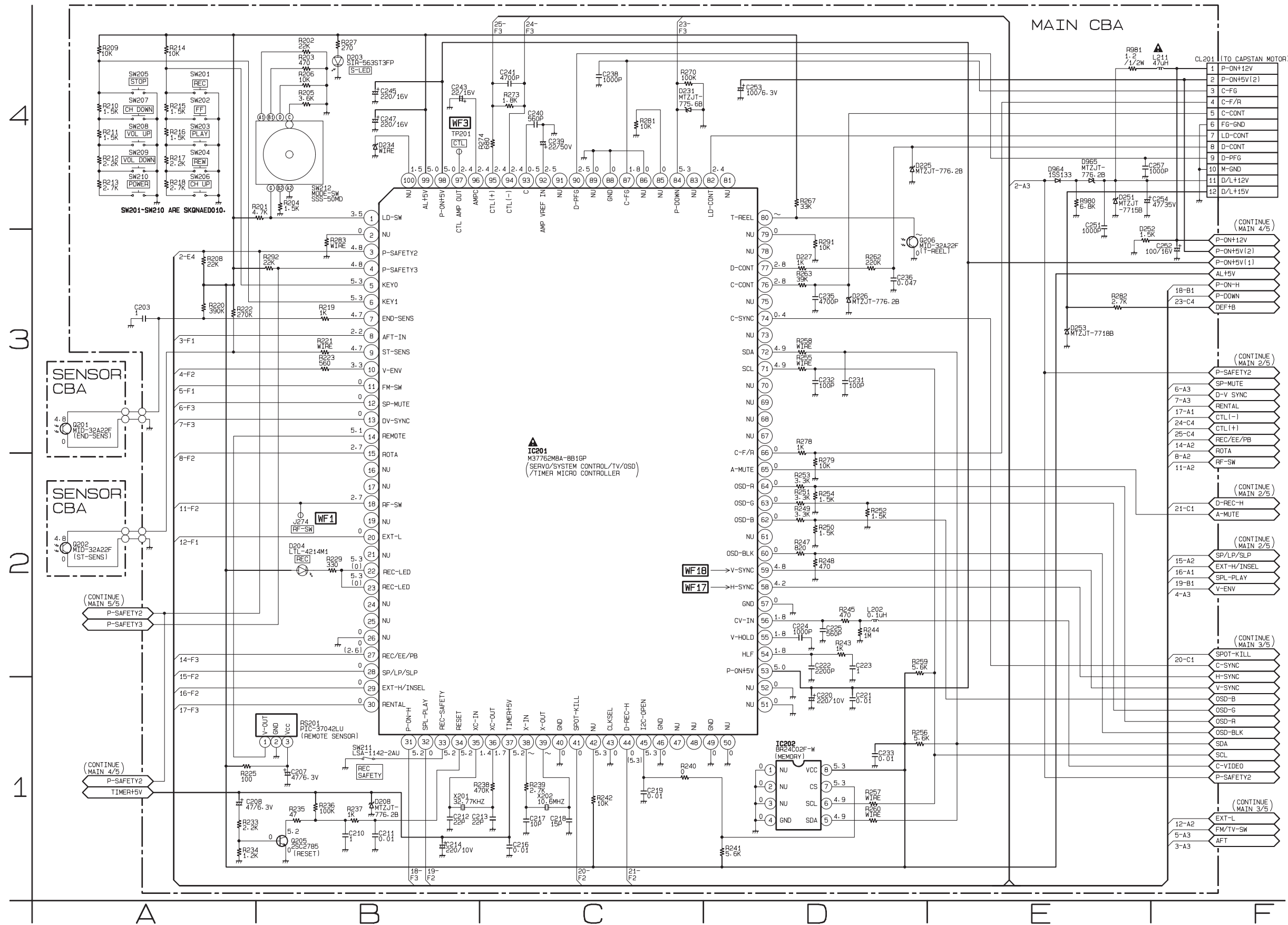
D1

E1

F1



# Main 1/5 Schematic Diagram



MAIN 1/5

Ref No.	Position
ICS	
IC201	C-3
IC202	D-1
TRANSISTORS	
Q205	B-1
Q206	D-3
CONNECTOR	
CL201	F-4
TEST POINTS	
J274	B-2
TP201	B-4

G4

H4

I4

J4

K4

L4

G3

H3

I3

J3

K3

L3

G2

H2

I2

J2

K2

L2

G1

H1

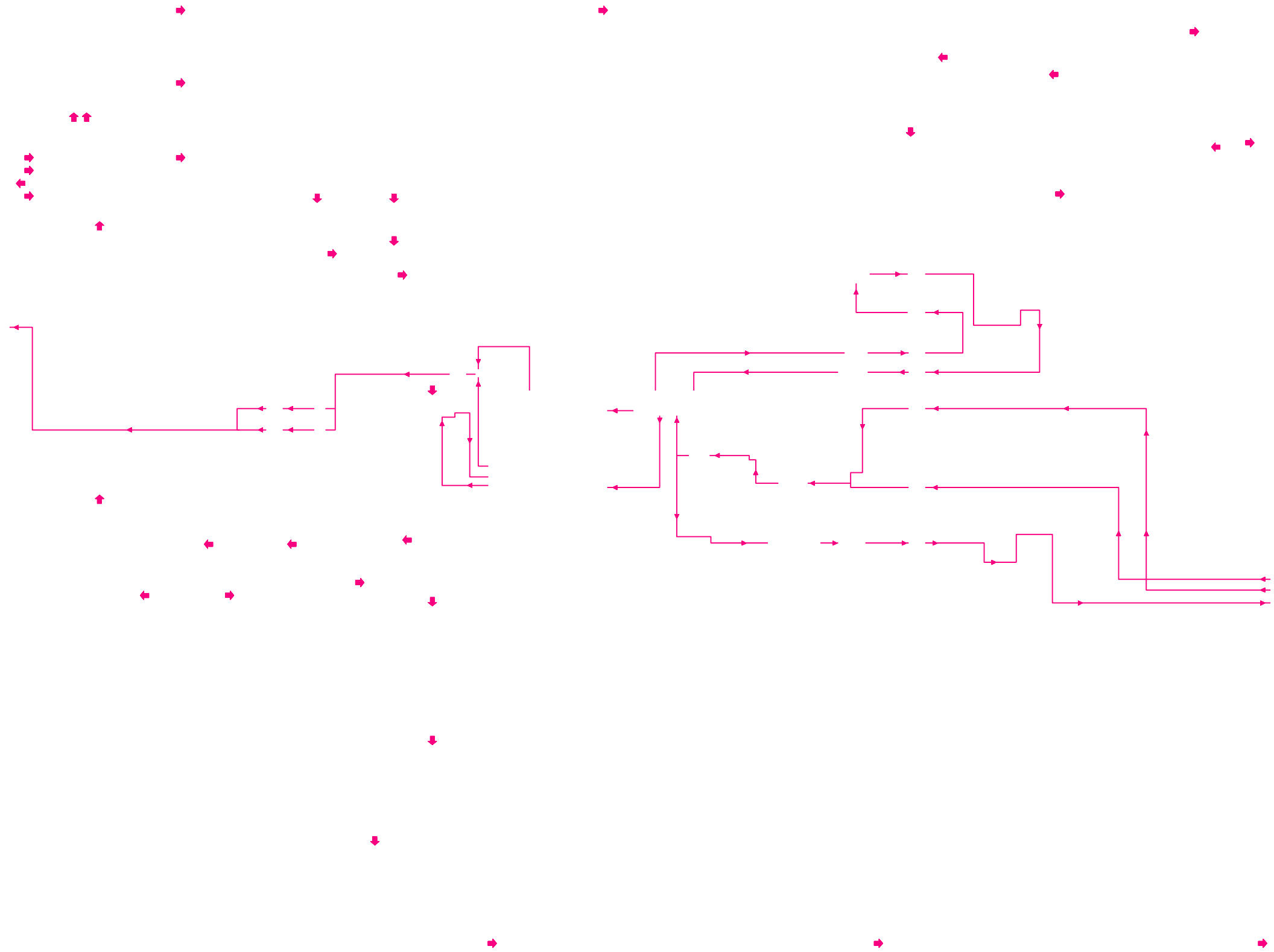
I1

J1

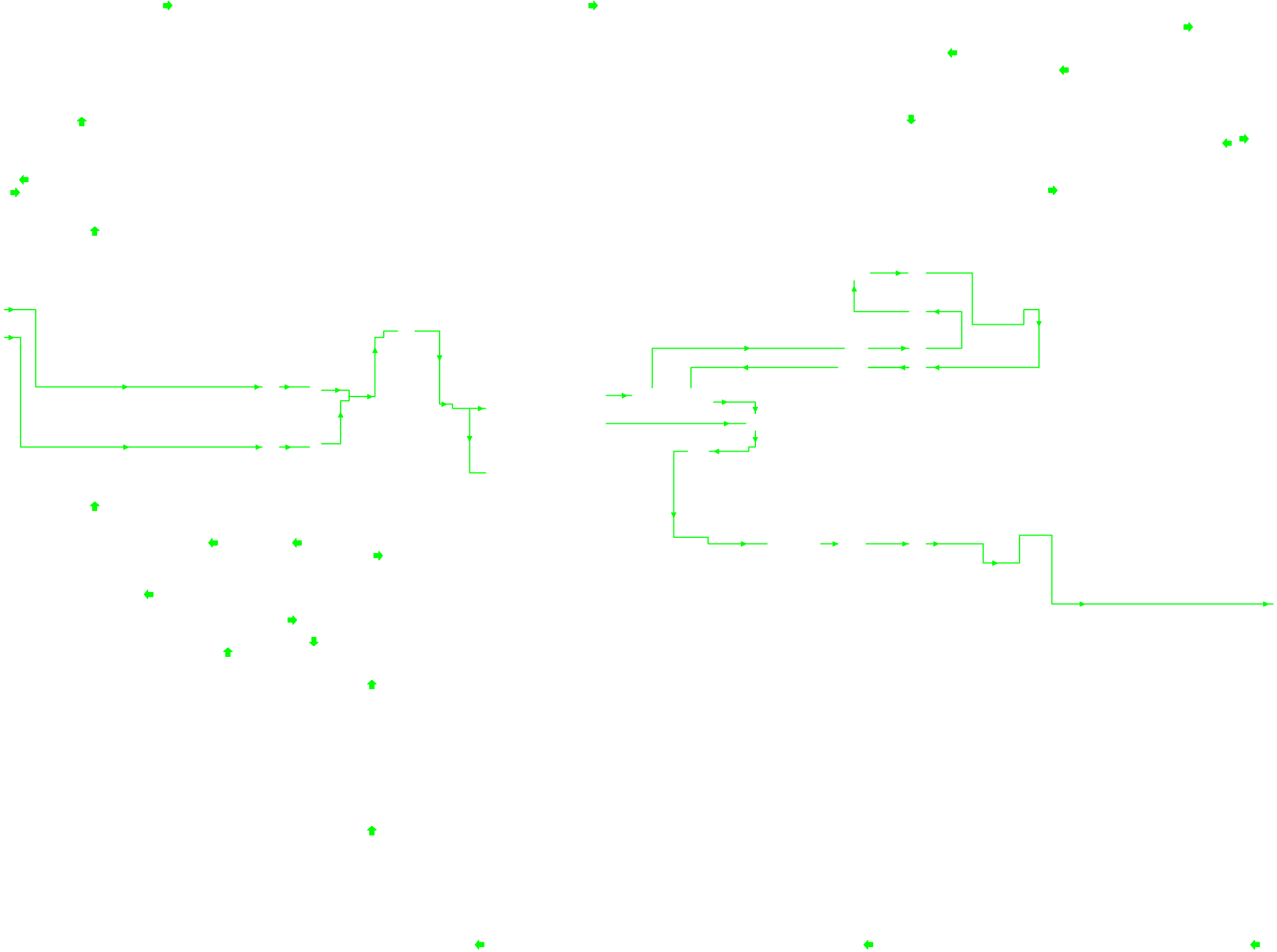
K1

L1

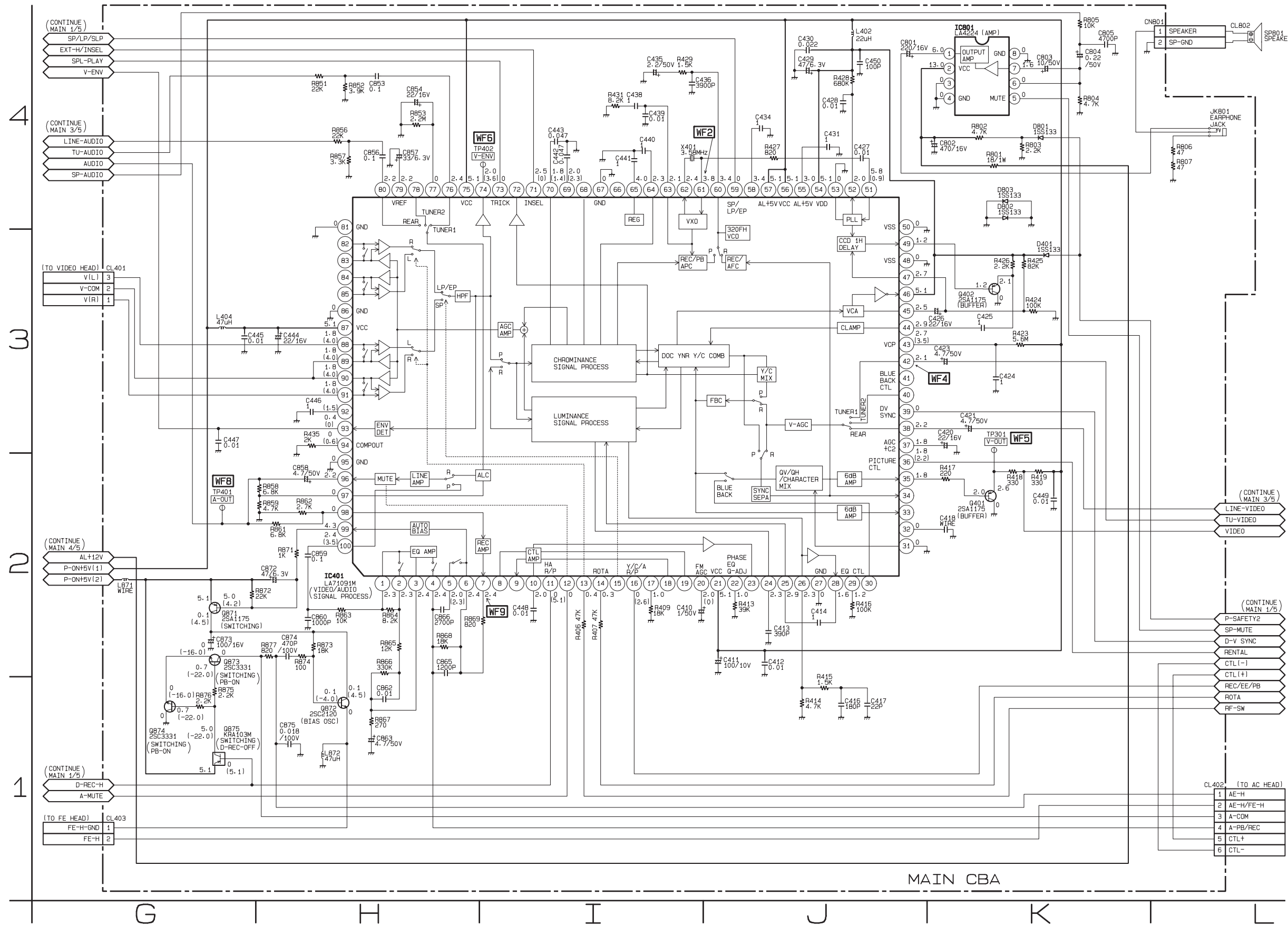
REC Video Signal  
REC Audio Signal



———— PB Video Signal  
← PB Audio Signal



# Main 2/5 Schematic Diagram



MAIN 2/5	
Ref No.	Position
ICs	
IC401	H-2
IC801	K-4
TRANSISTORS	
Q401	K-2
Q402	K-3
Q871	G-2
Q872	H-1
Q873	G-2
Q874	G-1
Q875	G-1
CONNECTORS	
CL401	G-3
CL402	L-1
CL403	G-1
CN801	L-4
TEST POINTS	
TP301	K-3
TP401	G-2
TP402	I-4

M4

N4

O4

P4

Q4

R4

M3

N3

O3

P3

Q3

R3

M2

N2

O2

P2

Q2

R2

M1

N1

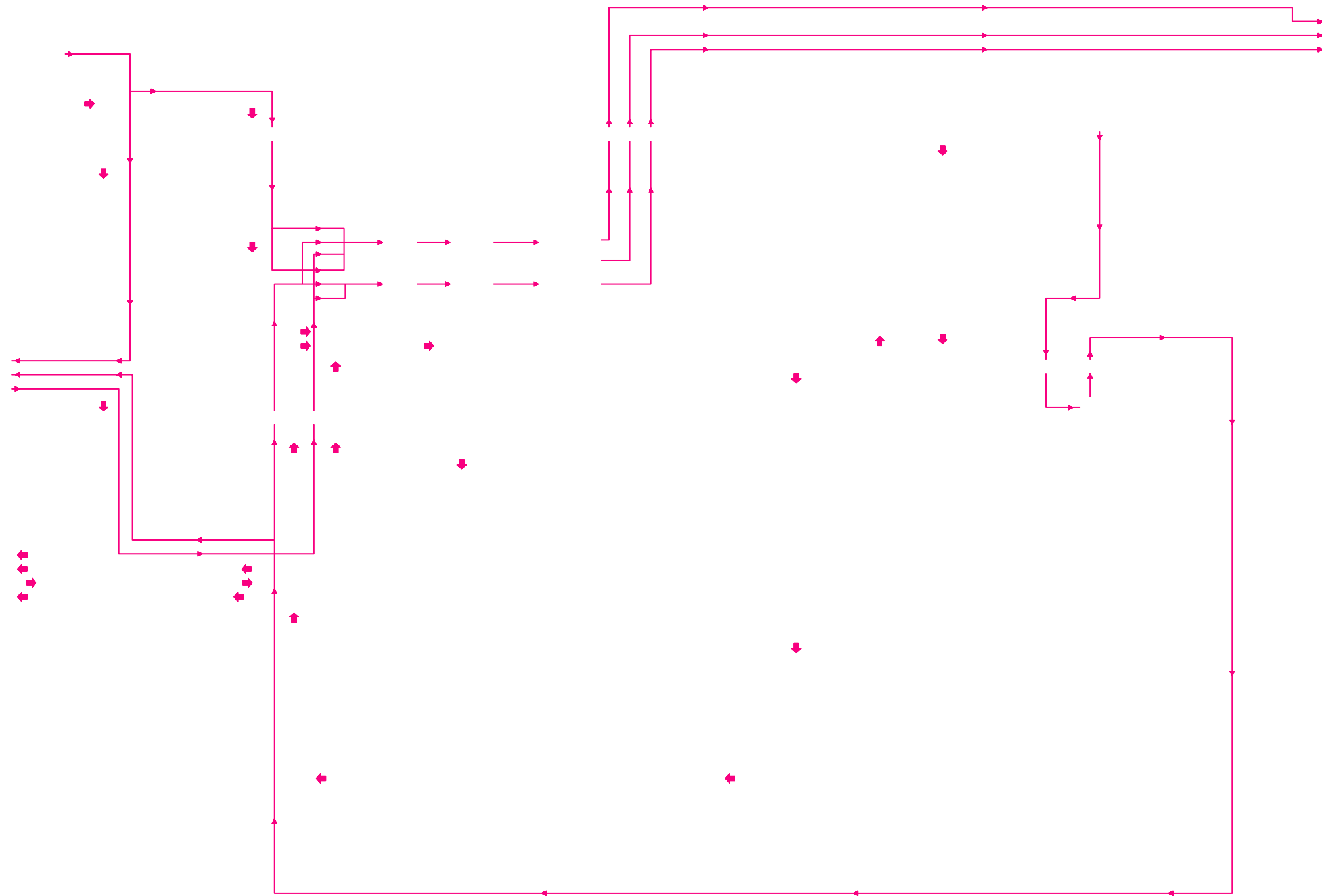
O1

P1

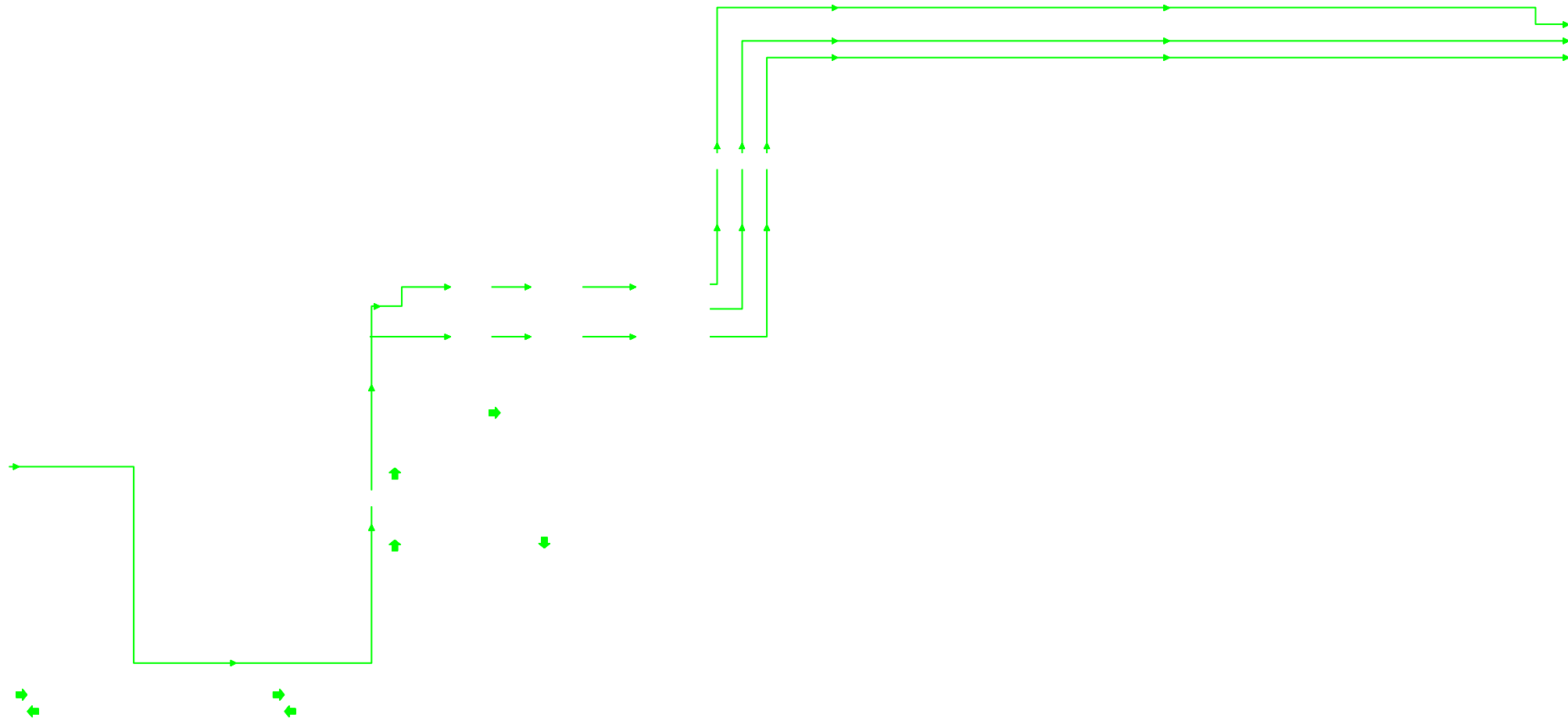
Q1

R1

— REC Video Signal  
← REC Audio Signal

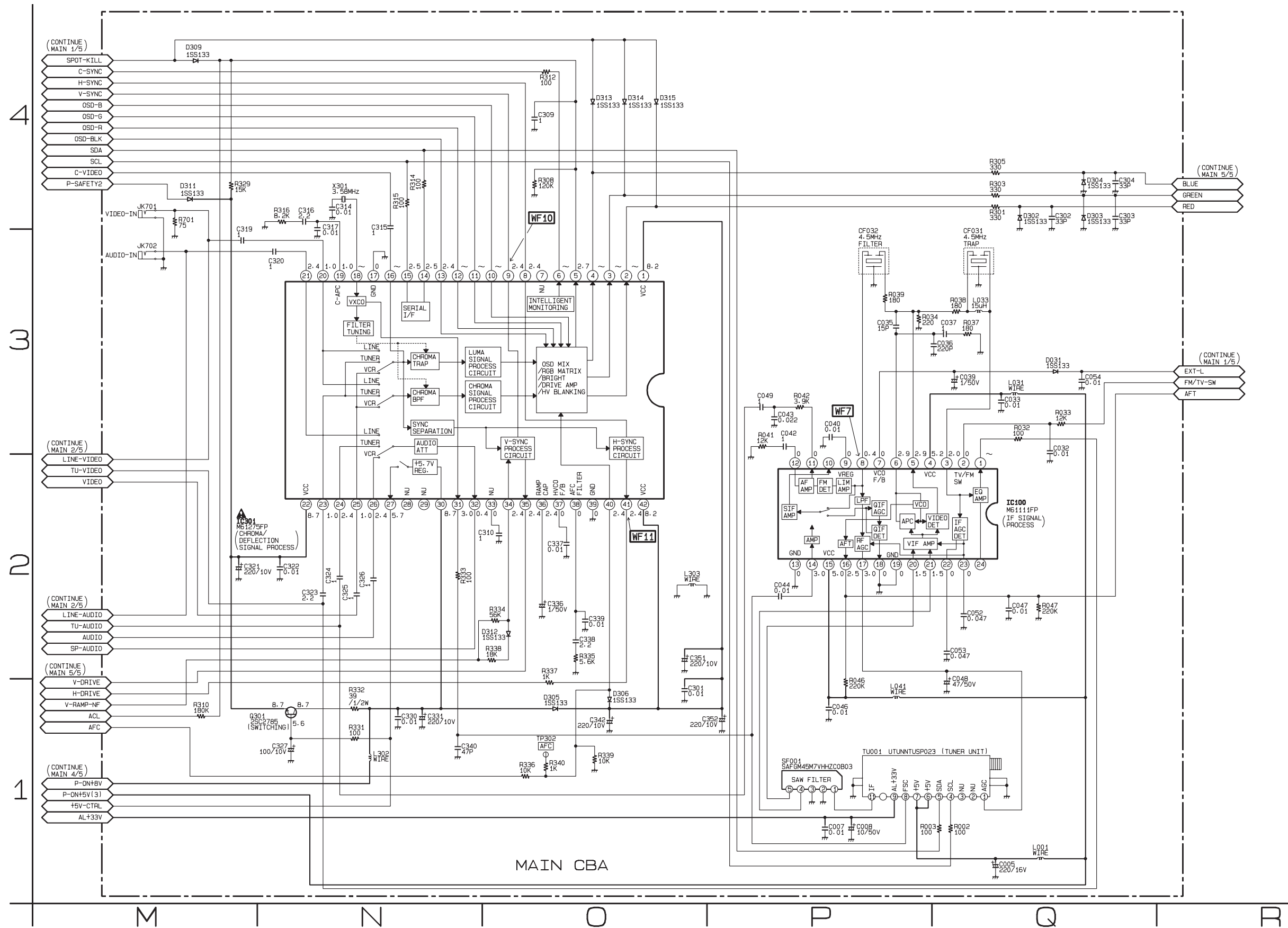


————— PB Video Signal  
← PB Audio Signal





# Main 3/5 Schematic Diagram



MAIN 3/5

Ref No.	Position
ICS	
IC100	Q-2
IC301	M-2
TRANSISTOR	
Q301	N-1
TEST POINT	
TP302	O-1

S3	T3	U3	V3	W3	X3
S2	T2	U2	V2	W2	X2
S1	T1	U1	V1	W1	X1

# Main 4/5 Schematic Diagram

## CAUTION !

Fixed voltage ( or Auto voltage selectable ) power supply circuit is used in this unit.  
If Main Fuse (F601) is blown, check to see that all components in the power supply circuit are not defective before you connect the AC plug to the AC power supply.  
Otherwise it may cause some components in the power supply circuit to fail.



**CAUTION:** FOR CONTINUED PROTECTION AGAINST RISK OF FIRE, REPLACE ONLY WITH SAME TYPE 4A, 125V FUSE.  
**ATTENTION:** UTILISER UN FUSIBLE DE RECHANGE DE MÊME TYPE DE 4A, 125V.

## NOTE :

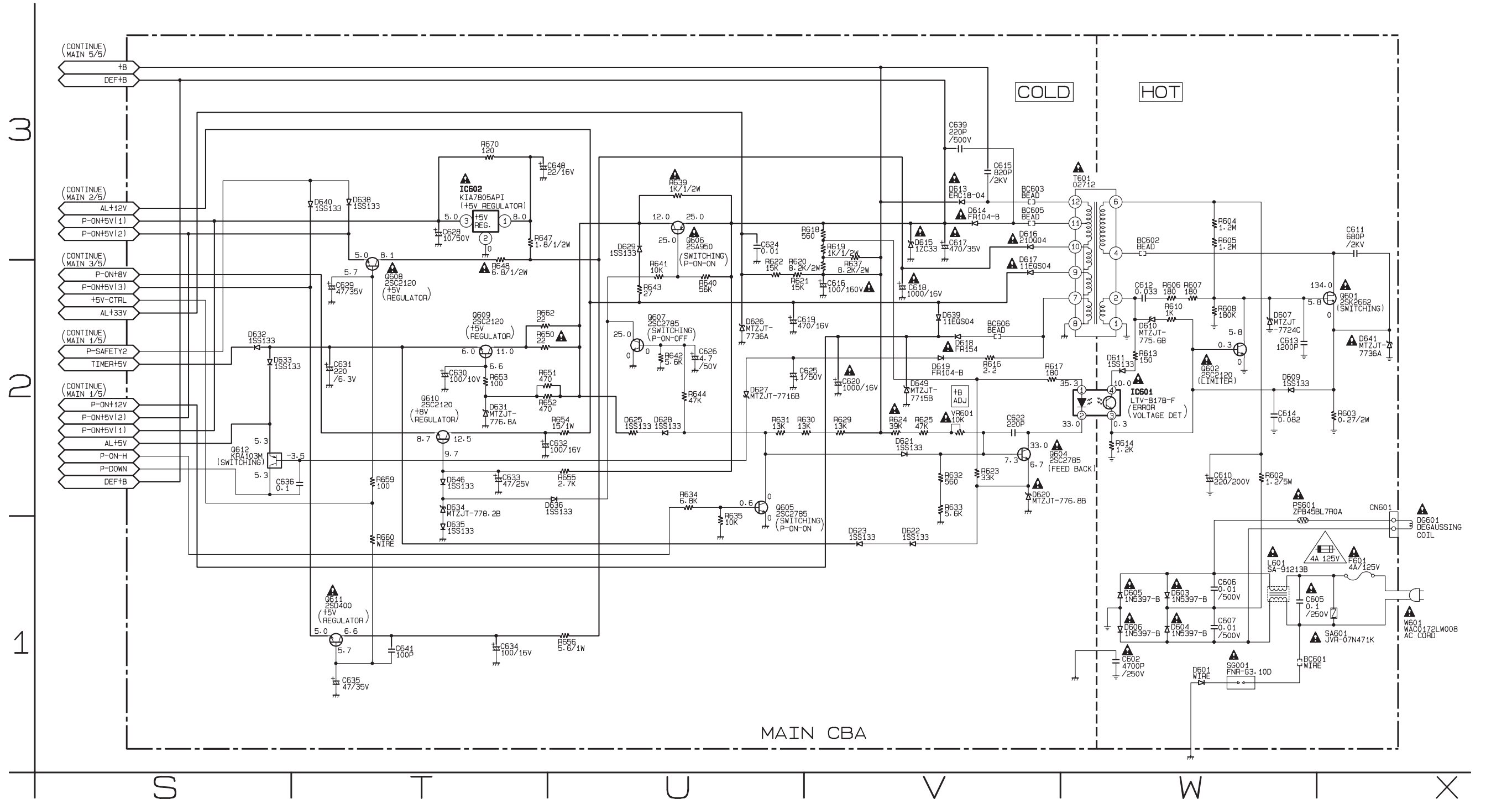
The voltage for parts in hot circuit is measured using hot GND as a common terminal.

MAIN 4/5

Ref No.	Position	Ref No.	Position
ICS		TRANSISTORS	
IC601	W-2	Q608	T-2
IC602	T-3	Q609	T-2
TRANSISTORS		Q610	T-2
Q601	X-2	Q611	T-1
Q602	W-2	Q612	S-2
Q604	V-2	CONNECTOR	
Q605	U-2	CN601	X-2
Q606	U-3	VARIABLE RESISTOR	
Q607	U-2	VR601	V-2

## VOLTAGE CHART (Power off mode)

Ref. No.	S	D	G
Q601	0.0	137.0	1.8
Ref. No.	E	C	B
Q602	0	3.2	0.5
Q605	0	7.0	0
Q606	7.0	7.0	7.0
Q608	5.0	7.5	5.7
Q609	6.0	6.5	6.6
Q610	0.7	4.7	1.3
Q611	0	2.4	0
Q612	5.3	5.3	0.8



MAIN CBA

Y3

Z3

AA3

BB3

CC3

DD3

Y2

Z2

AA2

BB2

CC2

DD2

Y1

Z1

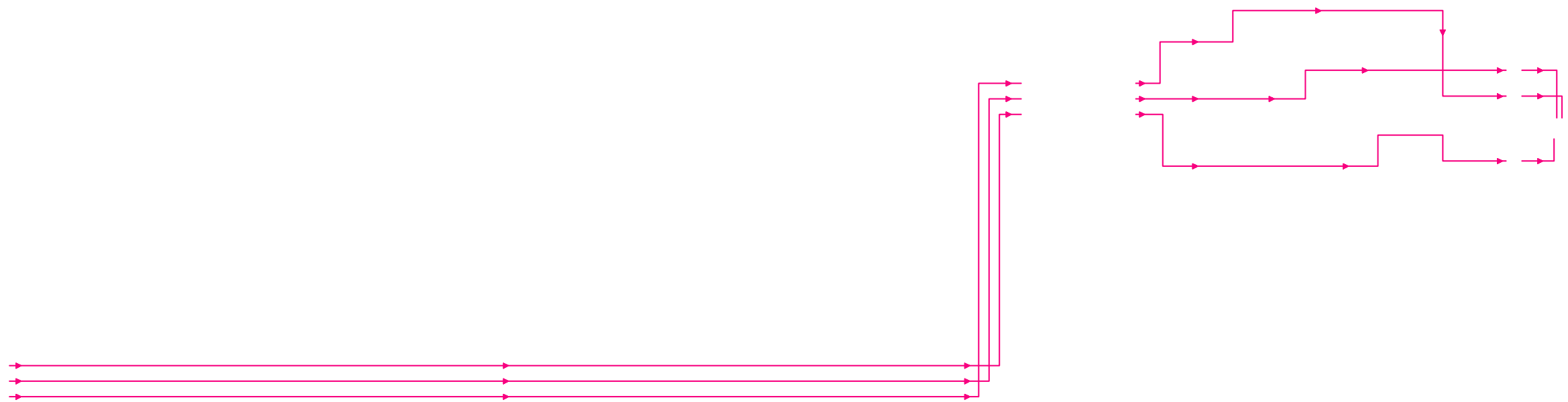
AA1

BB1

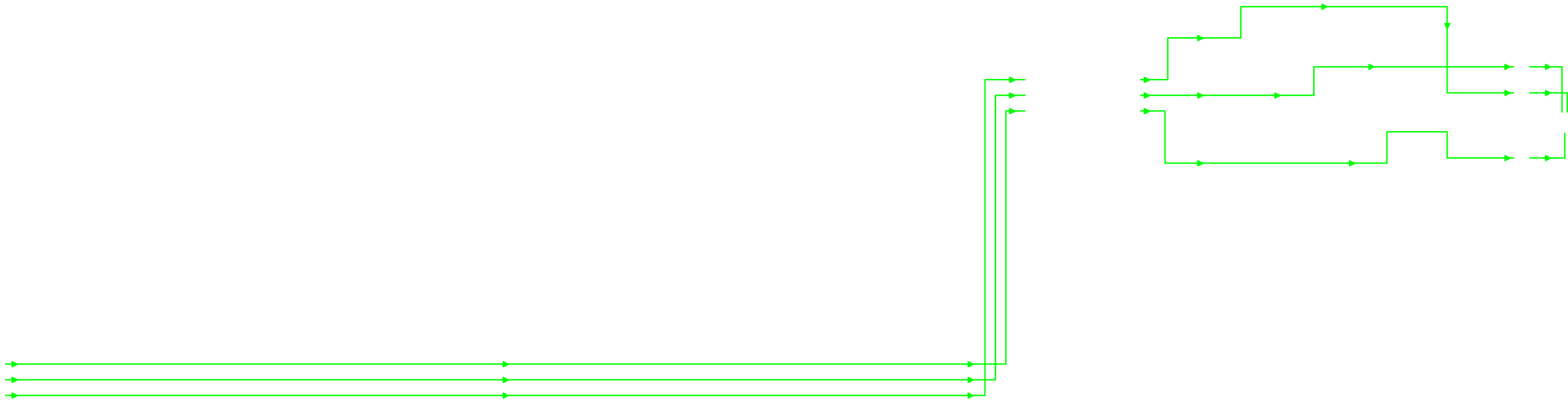
CC1

DD1

REC Video Signal



———— PB Video Signal



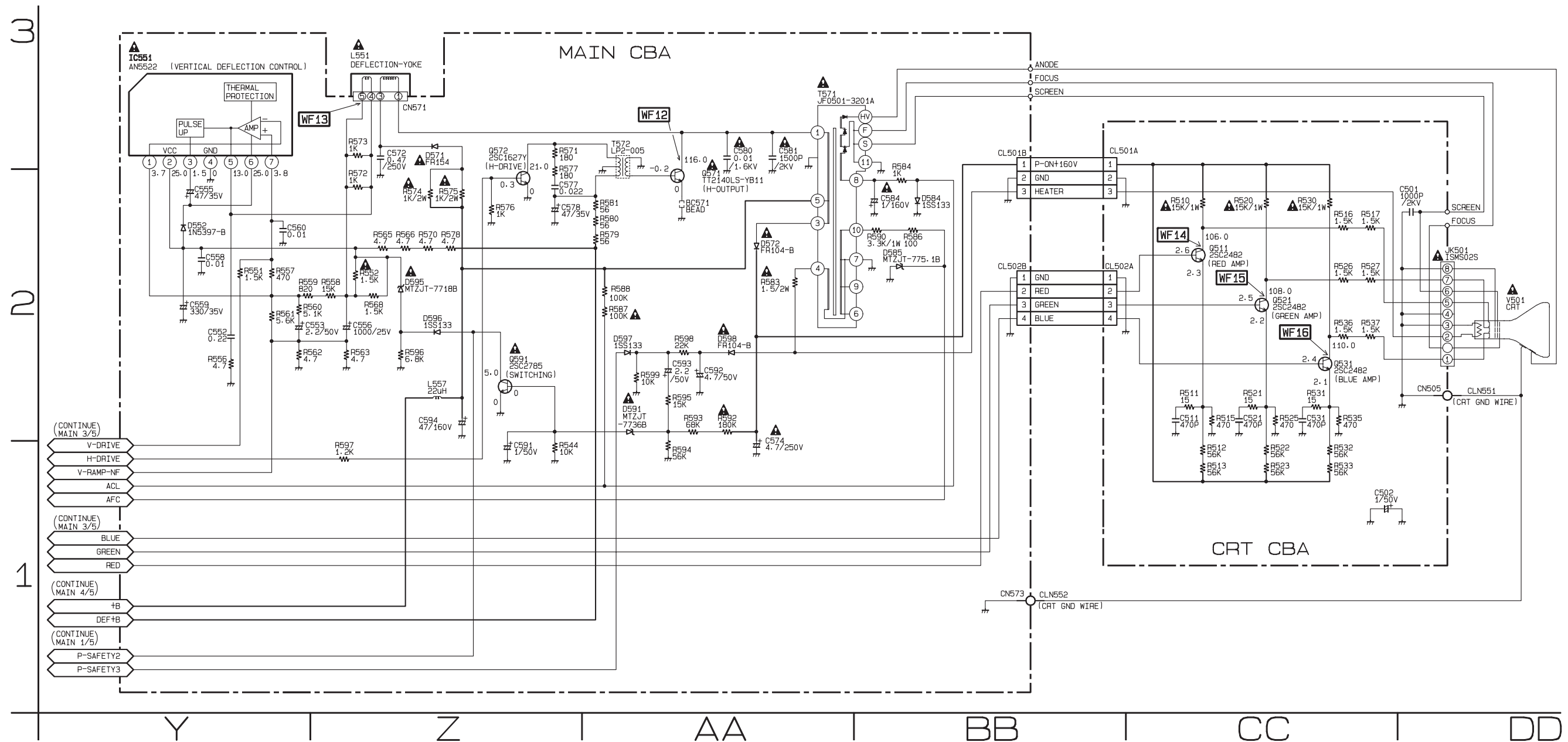
# Main 5/5 & CRT Schematic Diagram

## MAIN 5/5

Ref No.	Position
IC	
IC551	Y-3
TRANSISTORS	
Q571	AA-2
Q572	Z-3
Q591	Z-2
CONNECTORS	
CL501B	BB-3
CL502B	BB-2
CN571	Z-3
CN573	BB-1

## CRT

Ref No.	Position
TRANSISTORS	
Q511	CC-2
Q521	CC-2
Q531	CC-2
CONNECTORS	
CL501A	BB-3
CL502A	BB-2
CN505	DD-2



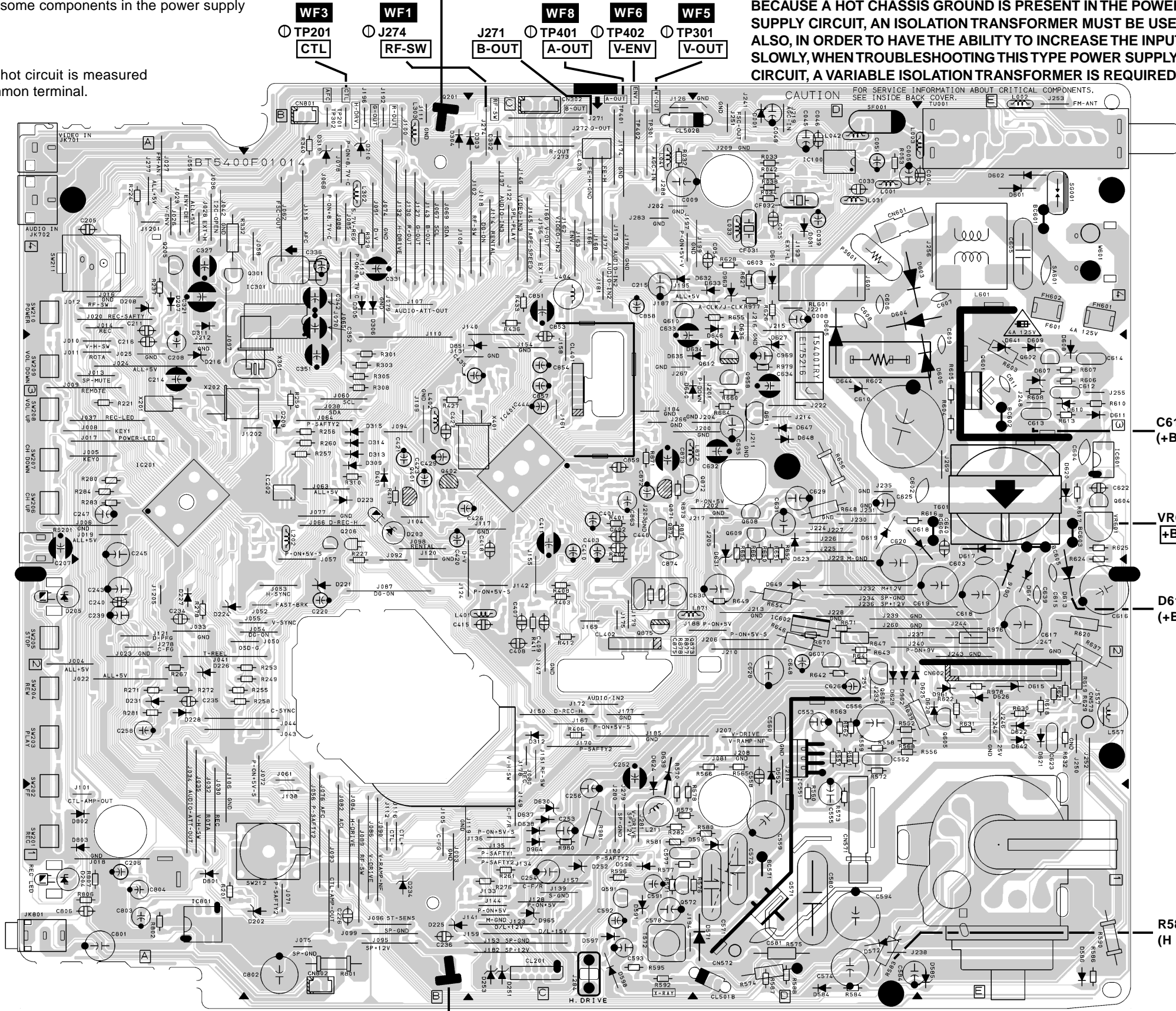
# Main CBA Top View

## CAUTION!

Fixed voltage ( or Auto voltage selectable ) power supply circuit is used in this unit.  
If Main Fuse (F601) is blown, check to see that all components in the power supply circuit are not defective before you connect the AC plug to the AC power supply.  
Otherwise it may cause some components in the power supply circuit to fail.

## NOTE:

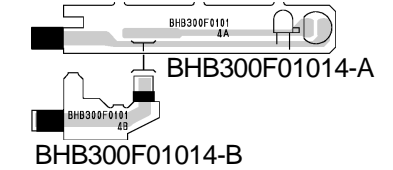
The voltage for parts in hot circuit is measured using hot GND as a common terminal.



**CAUTION:** FOR CONTINUED PROTECTION AGAINST RISK OF FIRE, REPLACE ONLY WITH SAME TYPE 4A, 125V FUSE.  
**ATTENTION:** UTILISER UN FUSIBLE DE RECHANGE DE MÊME TYPE DE 4A, 125V.

**BECAUSE A HOT CHASSIS GROUND IS PRESENT IN THE POWER SUPPLY CIRCUIT, AN ISOLATION TRANSFORMER MUST BE USED. ALSO, IN ORDER TO HAVE THE ABILITY TO INCREASE THE INPUT SLOWLY, WHEN TROUBLESHOOTING THIS TYPE POWER SUPPLY CIRCUIT, A VARIABLE ISOLATION TRANSFORMER IS REQUIRED.**

# Sensor CBA Top View



MAIN CBA	
Ref No.	Position
ICS	
IC100	D-4
IC201	A-3
IC202	B-3
IC301	B-4
IC401	C-3
IC551	D-2
IC601	E-3
IC602	D-2
IC801	A-1
TRANSISTORS	
Q205	A-4
Q206	B-3
Q301	B-4
Q401	B-3
Q402	B-3
Q571	D-1
Q572	C-1
Q591	C-1
Q601	E-3
Q602	E-3
Q604	E-3
Q605	E-2
Q606	D-2
Q607	D-2
Q608	D-3
Q609	D-3
Q610	D-3
Q611	D-3
Q612	D-3
Q871	C-3
Q872	D-3
Q873	C-2
Q874	C-3
Q875	C-2
CONNECTORS	
CL201	C-1
CL401	C-3
CL402	C-2
CL403	C-4
CL501B	D-1
CL502B	C-4
CN571	D-1
CN573	E-2
CN601	D-4
CN801	B-4
TEST POINTS	
J274	C-4
TP201	B-4
TP301	C-4
TP302	B-4
TP401	C-4
TP402	C-4
VARIABLE RESISTOR	
VR601	E-3

C613 GND (+B Adjustment)

VR601 (+B ADJ)

D613 Cathode (+B Adjustment)

R583 (H Adjustment)



# Main CBA Bottom View

## CAUTION !

Fixed voltage ( or Auto voltage selectable ) power supply circuit is used in this unit.  
 If Main Fuse (F601) is blown, check to see that all components in the power supply circuit are not defective before you connect the AC plug to the AC power supply.  
 Otherwise it may cause some components in the power supply circuit to fail.

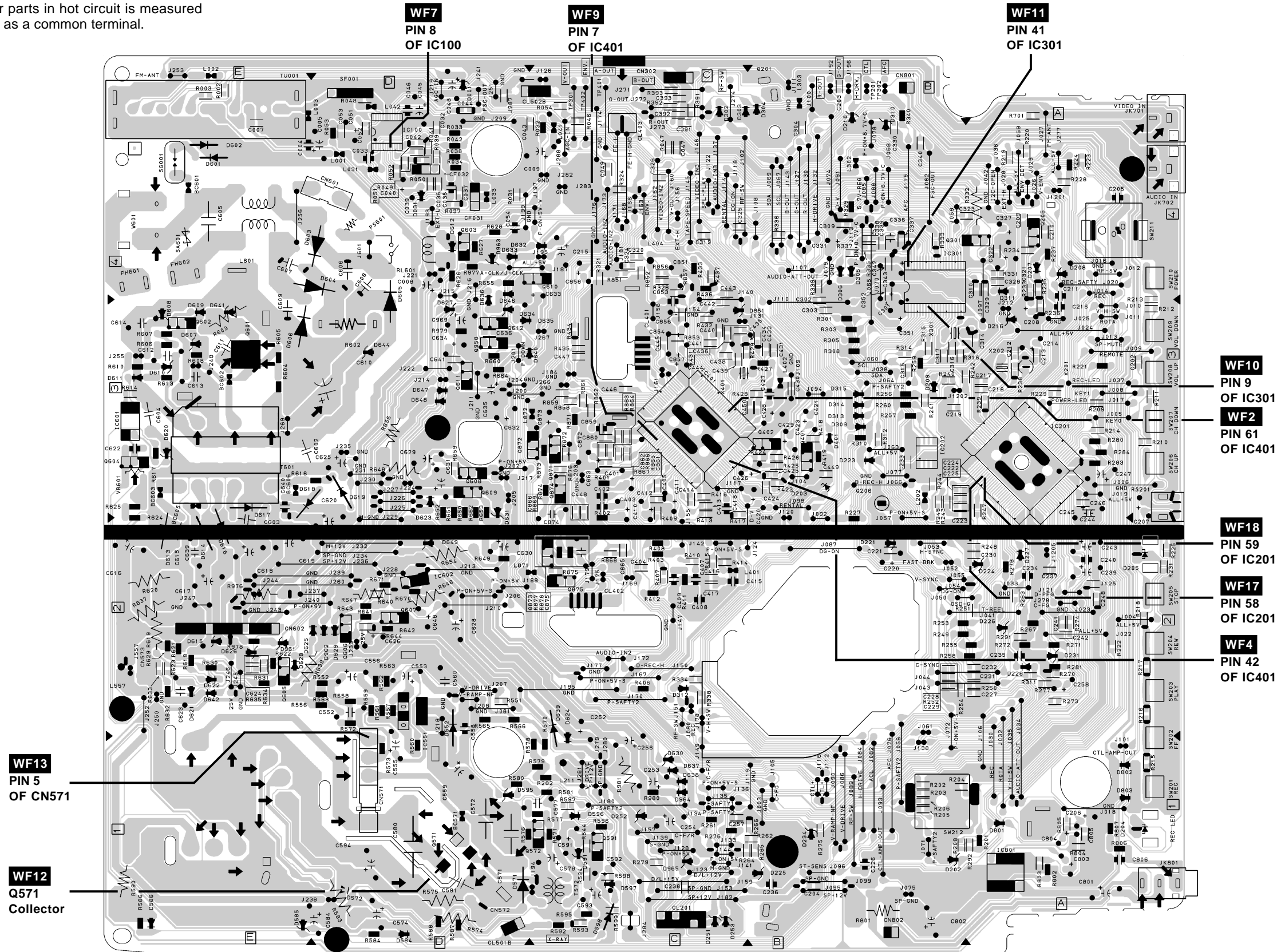
## NOTE :

The voltage for parts in hot circuit is measured using hot GND as a common terminal.



**CAUTION: FOR CONTINUED PROTECTION AGAINST RISK OF FIRE, REPLACE ONLY WITH SAME TYPE 4A, 125V FUSE. ATTENTION: UTILISER UN FUSIBLE DE RECHANGE DE MÊME TYPE DE 4A, 125V.**

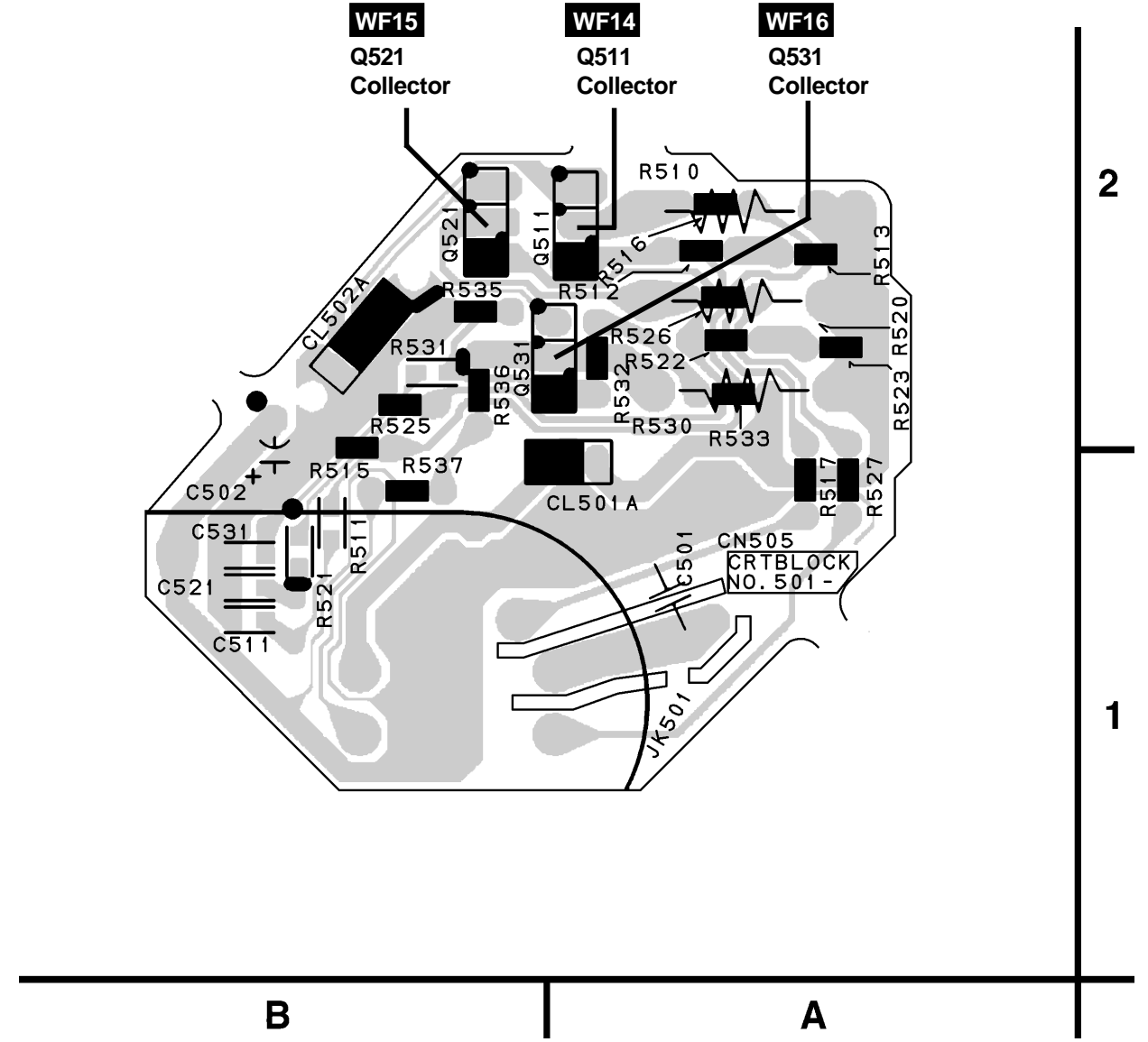
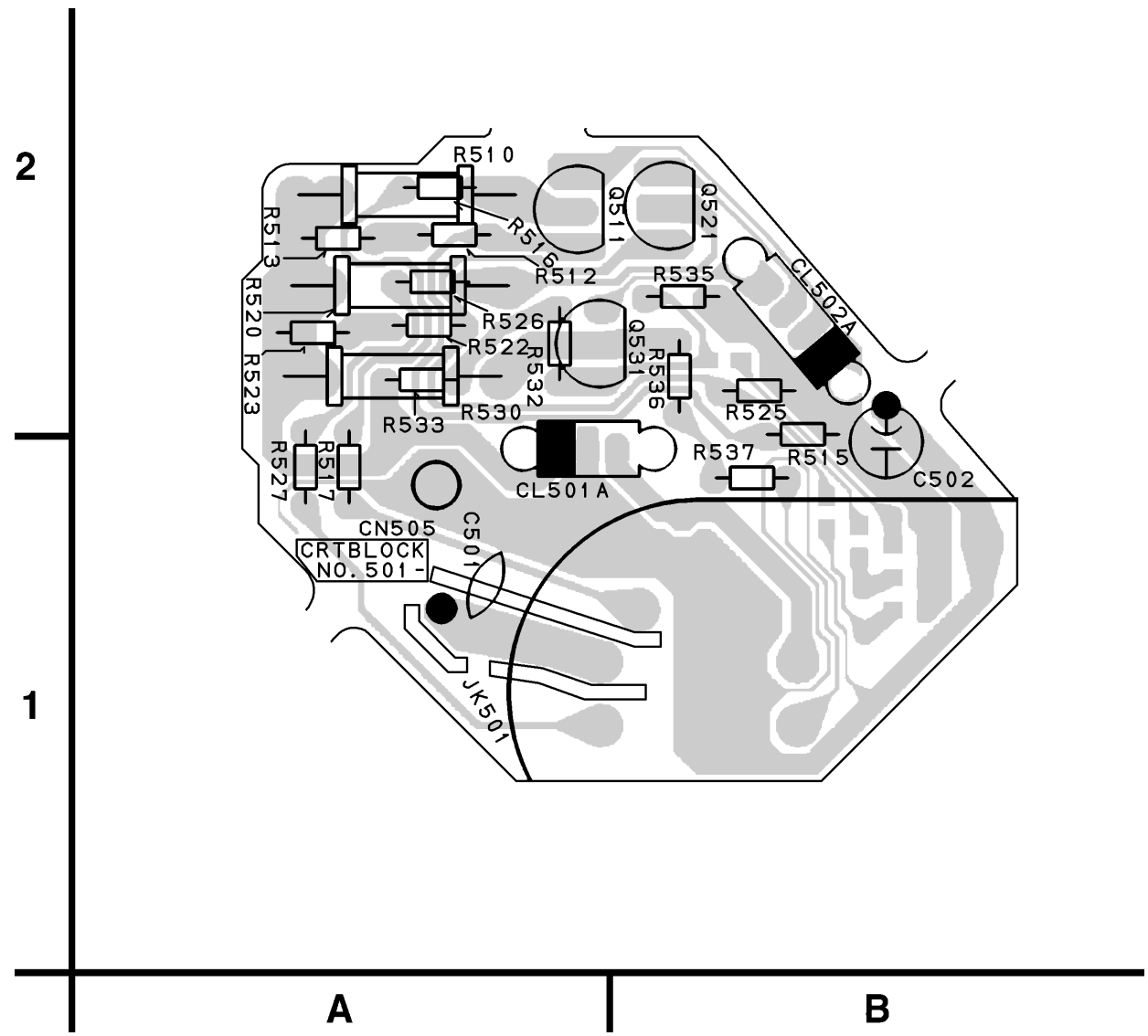
**BECAUSE A HOT CHASSIS GROUND IS PRESENT IN THE POWER SUPPLY CIRCUIT, AN ISOLATION TRANSFORMER MUST BE USED. ALSO, IN ORDER TO HAVE THE ABILITY TO INCREASE THE INPUT SLOWLY, WHEN TROUBLESHOOTING THIS TYPE POWER SUPPLY CIRCUIT, A VARIABLE ISOLATION TRANSFORMER IS REQUIRED.**



CRT CBA Top View

CRT CBA Bottom View

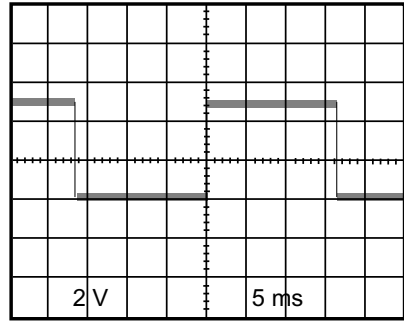
CRT CBA	
Ref No.	Position
TRANSISTORS	
Q511	B-2
Q521	B-2
Q531	B-2
CONNECTORS	
CL501A	A-1
CL502A	B-2
CN505	A-1



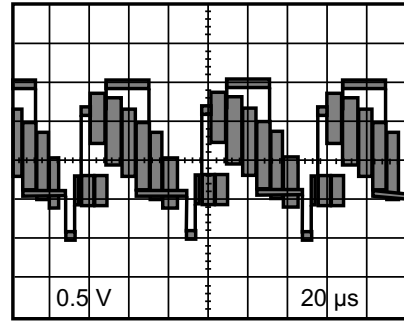
# WAVEFORMS

## WAVEFORM NOTES

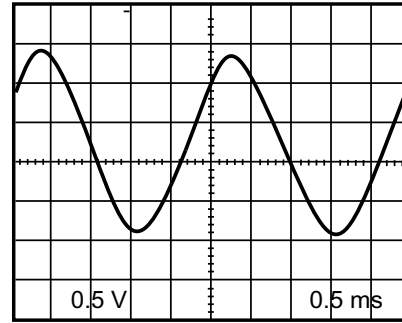
INPUT: NTSC COLOR BAR SIGNAL (WITH 1kHz AUDIO SIGNAL)  
 BRIGHTNESS, COLOR AND TINT CONTROLS: CENTER POSITION  
 CONTRAST CONTROL: APPROX 70%  
 VOLTAGES SHOWN ARE RANGE OF OSCILLOSCOPE SETTING.



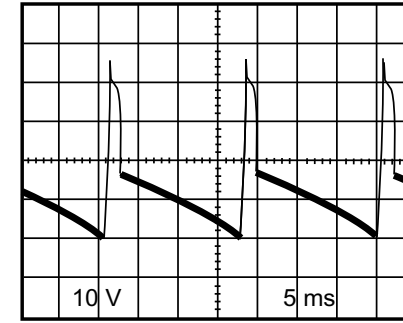
WF1 MAIN 1/5 SCHEMATIC DIAGRAM  
J274 RF-SW



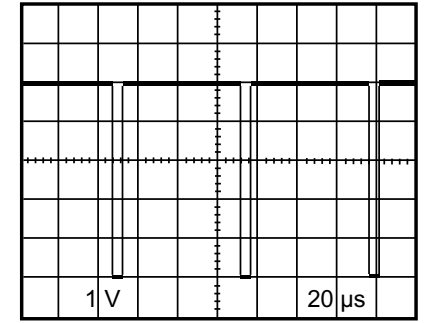
WF5 MAIN 2/5 SCHEMATIC DIAGRAM  
TP301 V-OUT



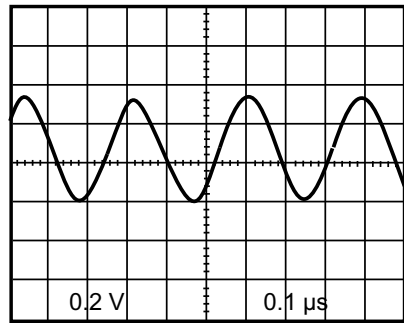
WF9 MAIN 2/5 SCHEMATIC DIAGRAM  
IC401 PIN 7



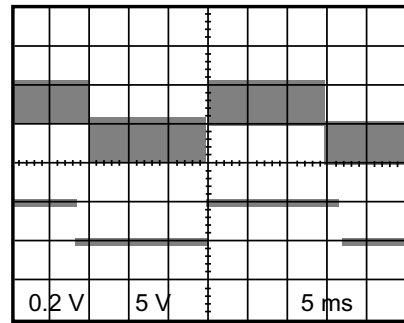
WF13 MAIN 5/5 & CRT SCHEMATIC  
DIAGRAM  
CN571 PIN 5



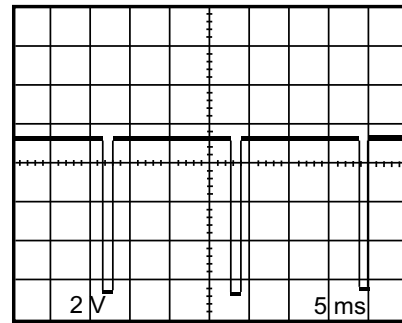
WF17 MAIN 1/5 SCHEMATIC DIAGRAM  
IC201 PIN 58



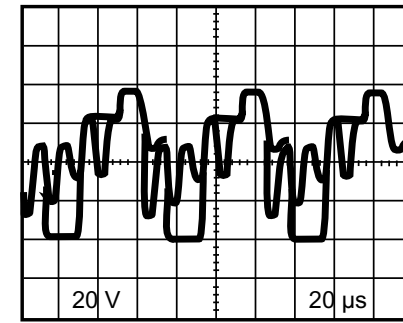
WF2 MAIN 2/5 SCHEMATIC DIAGRAM  
IC401 PIN 61



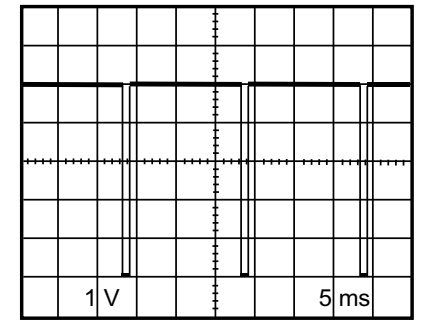
Upper: WF6 Lower: WF1  
MAIN 2/5 SCHEMATIC DIAGRAM  
TP402 V-ENV



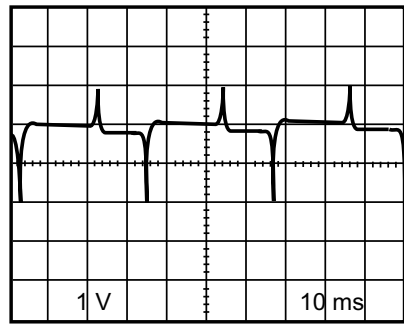
WF10 MAIN 3/5 SCHEMATIC DIAGRAM  
IC301 PIN 9



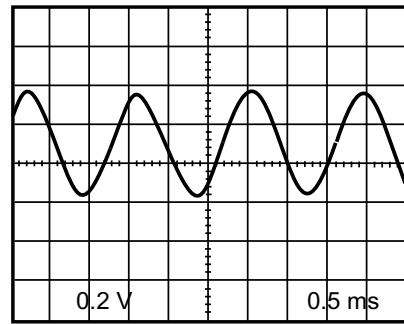
WF14 MAIN 5/5 & CRT SCHEMATIC  
DIAGRAM  
Q511 COLLECTOR



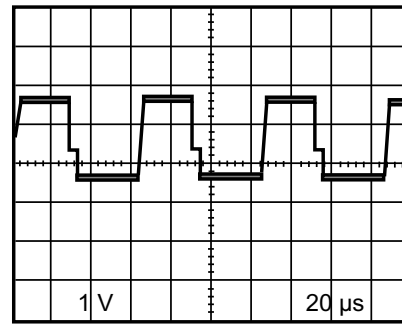
WF18 MAIN 1/5 SCHEMATIC DIAGRAM  
IC201 PIN 59



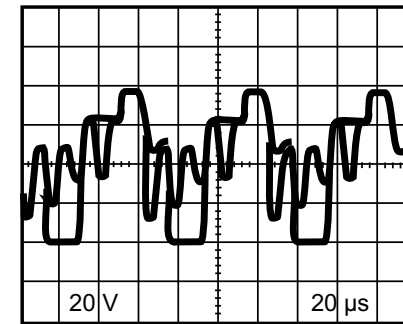
WF3 MAIN 1/5 SCHEMATIC DIAGRAM  
TP201 CTL



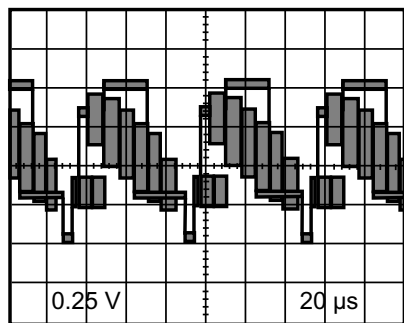
WF7 MAIN 3/5 SCHEMATIC DIAGRAM  
IC100 PIN 8



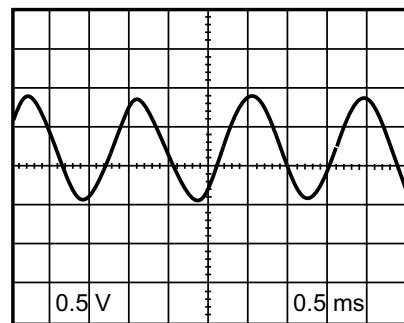
WF11 MAIN 3/5 SCHEMATIC DIAGRAM  
IC301 PIN 41



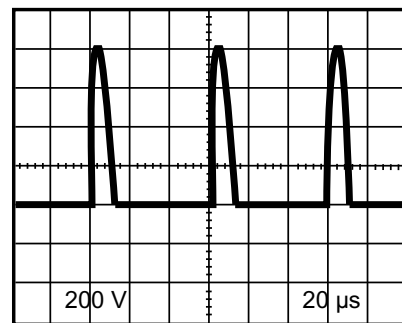
WF15 MAIN 5/5 & CRT SCHEMATIC  
DIAGRAM  
Q521 COLLECTOR



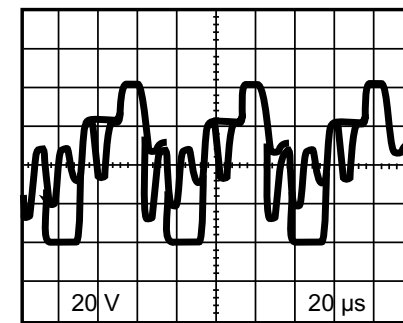
WF4 MAIN 2/5 SCHEMATIC DIAGRAM  
IC401 PIN 42



WF8 MAIN 2/5 SCHEMATIC DIAGRAM  
TP401 A-OUT

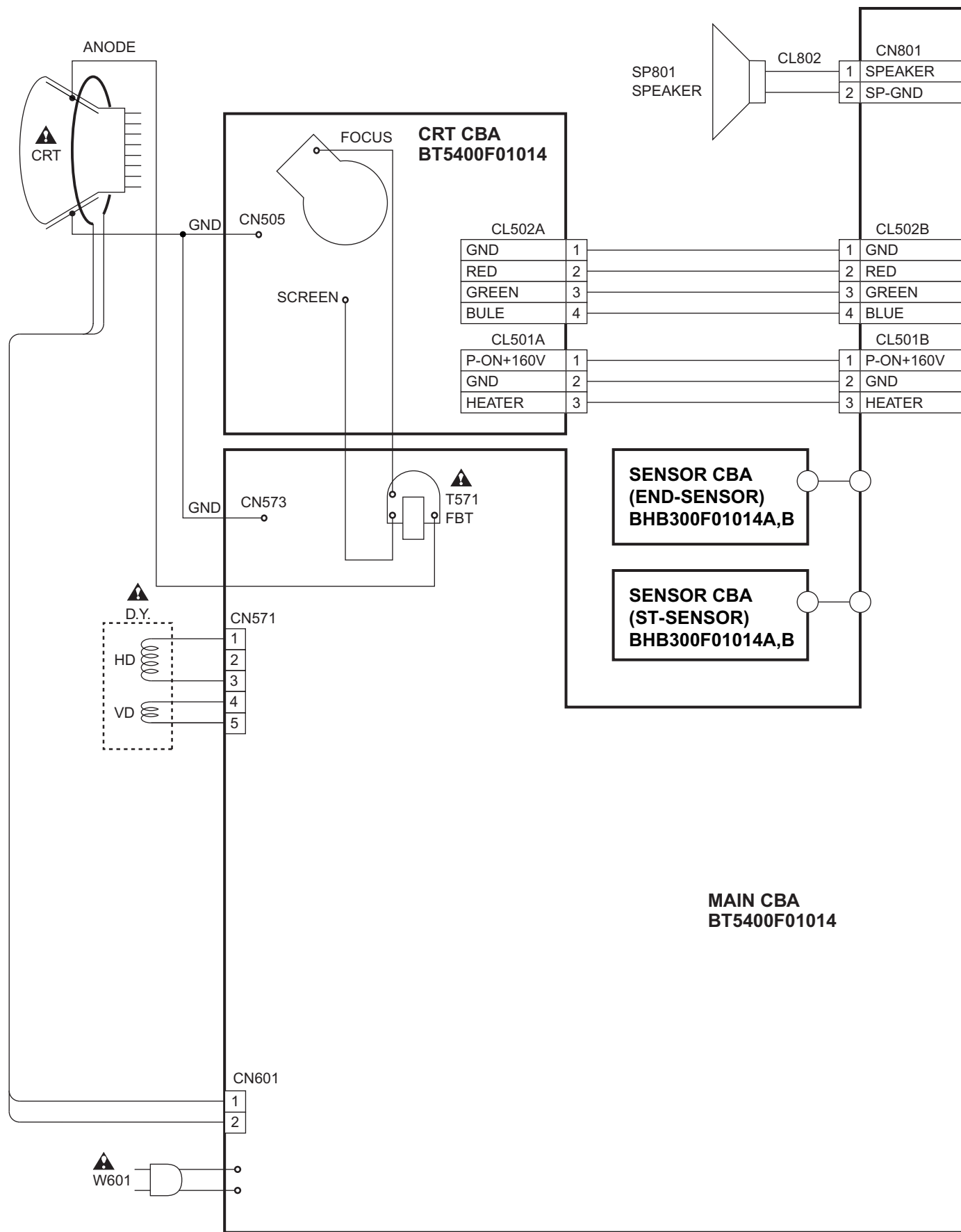


WF12 MAIN 5/5 & CRT SCHEMATIC  
DIAGRAM  
Q571 COLLECTOR

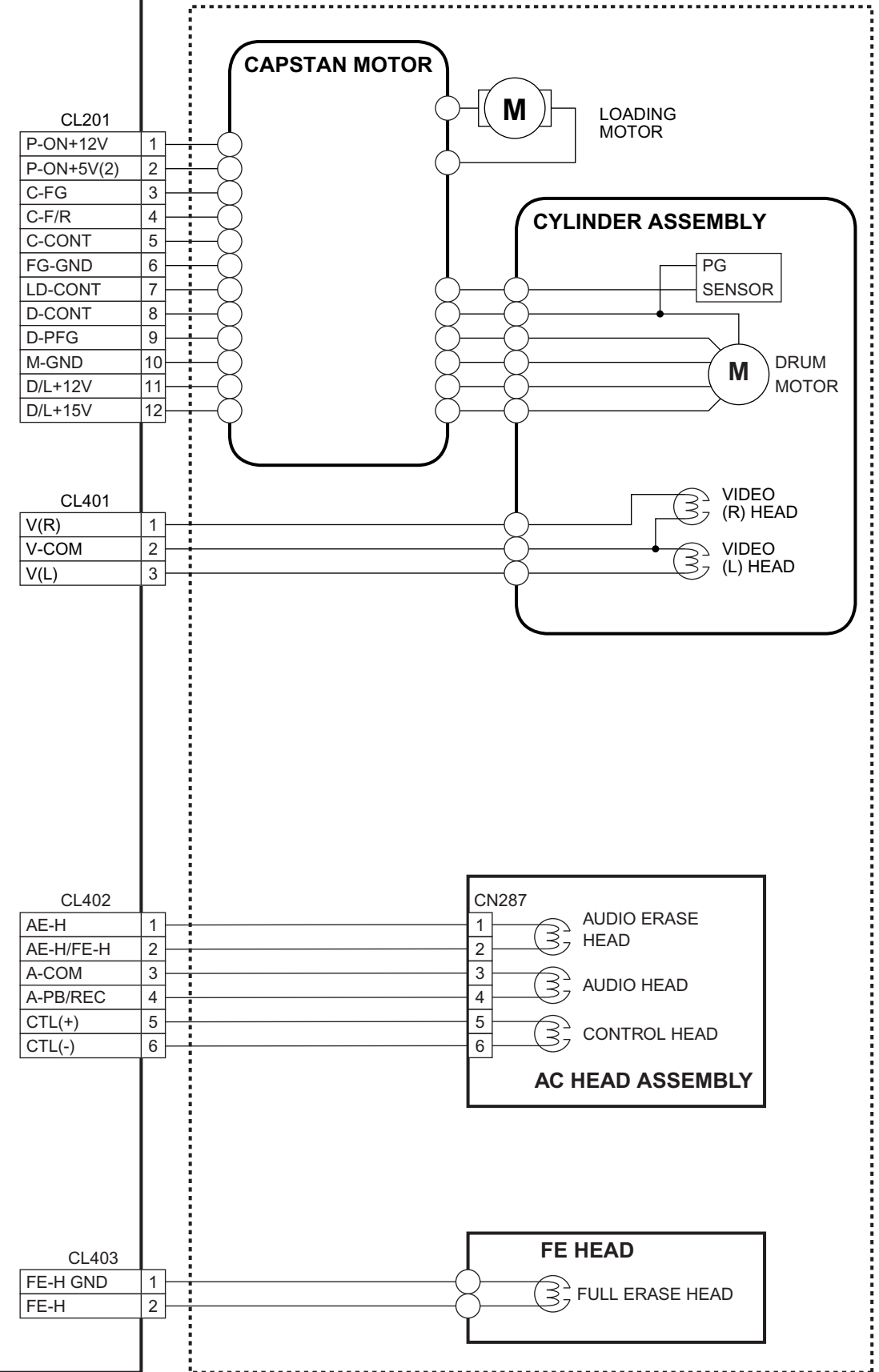


WF16 MAIN 5/5 & CRT SCHEMATIC  
DIAGRAM  
Q531 COLLECTOR

# WIRING DIAGRAM



## WIRING DIAGRAM FOR SECTION 2 (DECK MECHANISM)



# SYSTEM CONTROL TIMING CHARTS

Chart 1

1. EJECT (POWER OFF) -> CASSETTE IN (POWER ON) -> STOP(B) -> STOP(A) -> PLAY -> RS -> FS -> PLAY -> STILL(N-CANCEL) -> PLAY -> STOP(A)

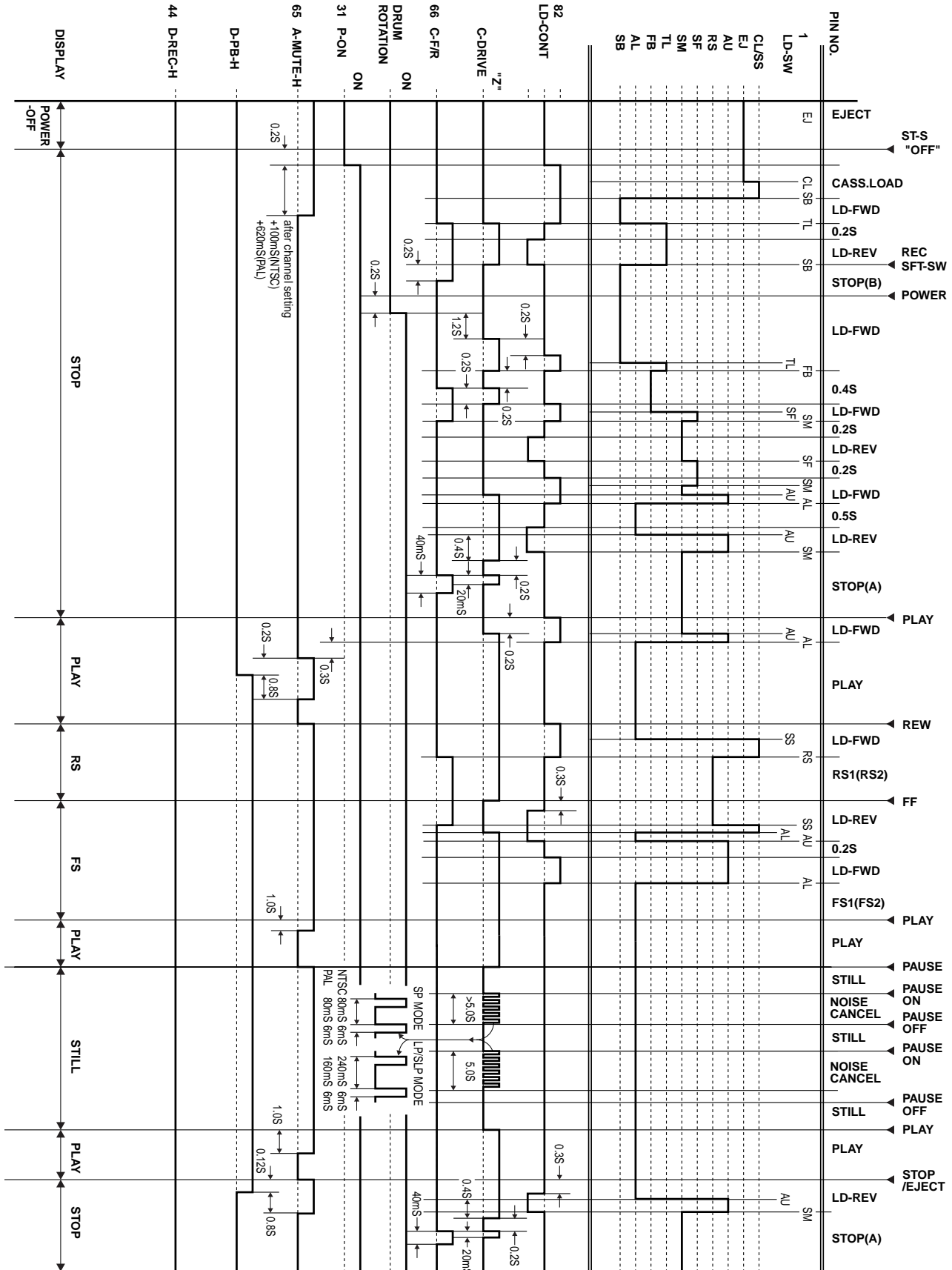
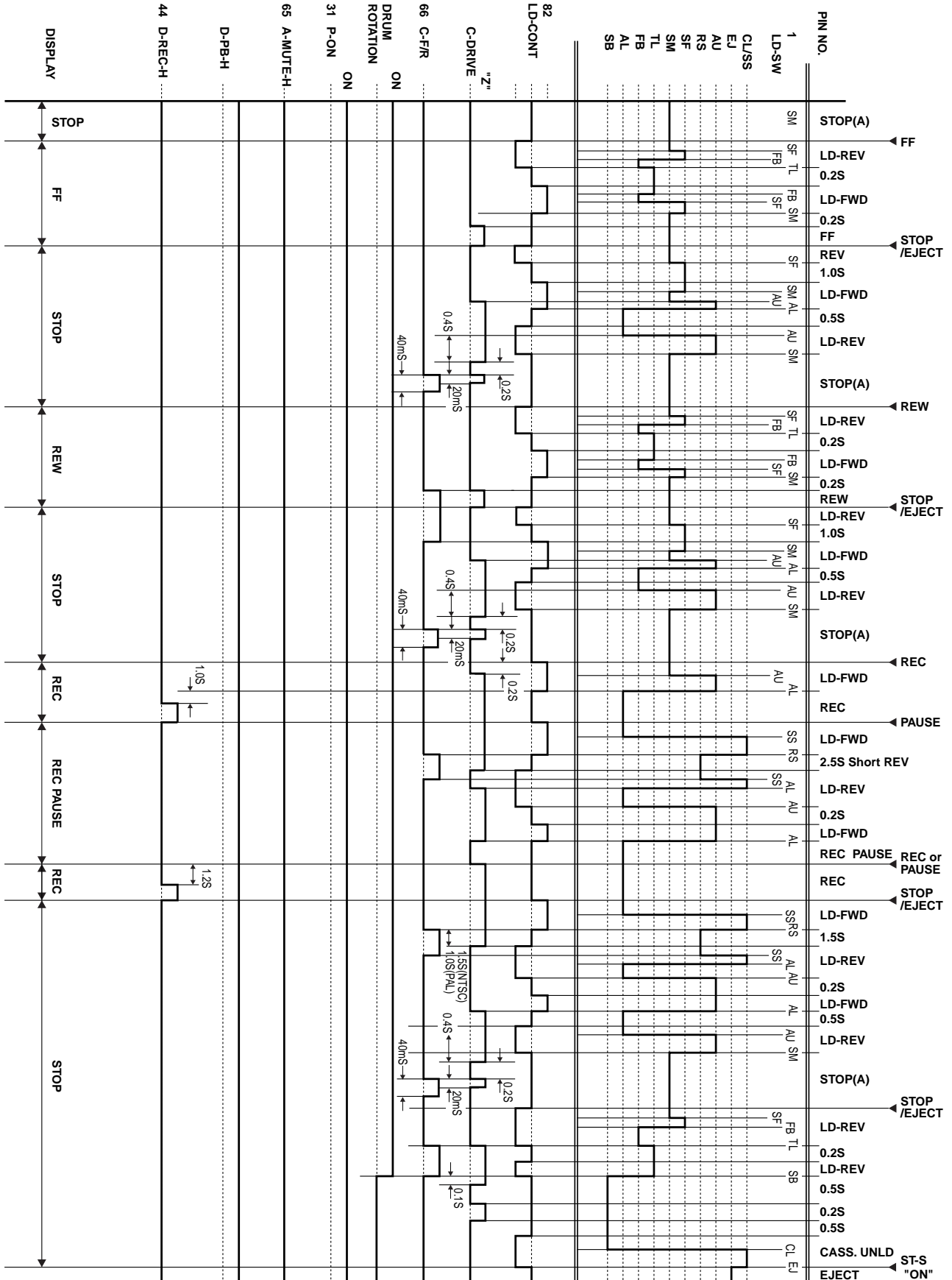


Chart 2

2. STOP(A) -> FF -> STOP(A) -> REW -> STOP(A) -> REC -> PAUSE -> PAUSE or REC -> STOP(A) -> EJECT



# IC PIN FUNCTION DESCRIPTIONS

## IC 201 (TV/VCR Micro Computer)

“H” ≥ 4.5V, “L” ≤ 1.0V

Pin No.	IN/OUT	Signal Name	Function
1	IN	LD-SW	Loading Switch Input
2	-	NU	Not Used
3	IN	P-SAFETY 2	Power Supply Failure Detection 2
4	IN	P-SAFETY 3	Power Supply Failure Detection 3
5	IN	KEY0	Key 0 Input
6	IN	KEY1	Key 1 Input
7	IN	END-SENS	End-Sensor
8	IN	AFT-IN	AFT Input
9	IN	ST-SENS	Start-Sensor
10	IN	V-ENV	Video Envelope Input
11	OUT	FM-SW	Switching IF IC VCO
12	OUT	SP-MUTE	Speaker Mute Output
13	OUT	D-V SYNC	Artificial V-Sync Output
14	IN	REMOTE	Remote Signal Input
15	OUT	ROTA	Color Phase Rotary Changeover Signal
16	-	NU	Not Used
17	-	NU	Not Used
18	OUT	RF-SW	Video Head Switching Pulse
19	-	NU	Not Used
20	OUT	EXT-L	External Input or Playback = Output
21	-	NU	Not Used
22	OUT	REC-LED	Recording LED Control Signal
23	OUT	REC-LED	Recording LED Control Signal
24	-	NU	Not Used
25	-	NU	Not Used
26	-	NU	Not Used
27	OUT	REC/EE/PB	YCA IC Mode Output
28	IN/OUT	SP/LP/SLP	Tape Speed Control Output
29	OUT	EXT-H/INSEL	External Input or Playback Signal Input Selector Control Signal

Pin No.	IN/OUT	Signal Name	Function
30	OUT	RENTAL	Rental Position Control Signal
31	OUT	P-ON-H	Power On Signal at High
32	OUT	SPL-PLAY	Special Playback Control Signal
33	IN	REC-SAFETY	Record Protection Tab Detection
34	IN	RESET	System Reset Signal (Reset="L")
35	IN	XC-IN	Sub Clock 32 kHz
36	OUT	XC-OUT	Sub Clock 32 kHz
37	-	TIMER+5V	Vcc
38	IN	X-IN	Main Clock Input
39	OUT	X-OUT	Main Clock Output
40	-	GND	GND
41	OUT	SPOT-KILL	Counter-measure for Spot
42	-	NU	Not Used
43	IN	CLKSEL	Clock Select (GND)
44	OUT	D-REC-H	Delayed Record Signal
45	IN	I2C-OPEN	White Balance Adjust Mode Judgment
46	-	GND	GND
47	-	NU	Not Used
48	-	NU	Not Used
49	-	GND	OSD GND
50	-	NU	Not Used
51	-	NU	Not Used
52	-	NU	Not Used
53	-	P-ON+5V	OSD Vcc
54	-	HLF	HLF
55	IN	V-HOLD	VHOLD
56	IN	CV-IN	Video Signal Input
57	-	GND	GND
58	IN	H-SYNC	H-SYNC Input
59	IN	V-SYNC	V-SYNC Input
60	OUT	OSD-BLK	Output for Picture Cut off
61	-	NU	Not Used
62	OUT	OSD-B	Blue Output
63	OUT	OSD-G	Green Output

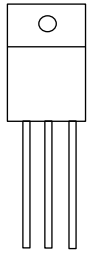
Pin No.	IN/ OUT	Signal Name	Function
64	OUT	OSD-R	Red Output
65	OUT	A-MUTE	Audio Mute Output
66	OUT	C-F/R	Capstan Motor FWD/REV Control Signal
67	-	NU	Not Used
68	-	NU	Not Used
69	-	NU	Not Used
70	-	NU	Not Used
71	OUT	SCL	E2PROM/CHROMA IC Tuner Communication Clock
72	IN/ OUT	SDA	E2PROM/CHROMA IC Tuner Communication Data
73	-	NU	Not Used
74	IN	C-SYNC	C-Sync Input
75	-	NU	Not Used
76	OUT	C-CONT	Capstan Motor Control Signal
77	OUT	D-CONT	Drum Motor Control Signal
78	-	NU	Not Used
79	-	NU	Not Used
80	IN	T-REEL	Take Up Reel Rotation Signal
81	-	NU	Not Used
82	OUT	LD-CONT	Loading Motor Control Signal
83	-	NU	Not Used
84	IN	P-DOWN	Power Voltage Down Detector Signal
85	-	NU	Not Used
86	-	NU	Not Used
87	IN	C-FG	Capstan Motor Rotation Detection Pulse
88	-	GND	GND (AMP)
89	-	NU	Not Used
90	IN	D-PFG	Drum Motor Pulse Generator
91	-	NU	Not Used
92	OUT	AMP VREF IN	Standard Voltage Input
93	-	C	C
94	IN/ OUT	CTL (-)	CTL (-)

Pin No.	IN/ OUT	Signal Name	Function
95	IN/ OUT	CTL (+)	CTL (+)
96	-	AMPC	AMPC
97	OUT	CTL AMP OUT	Control Amp Output
98	-	P-ON+5V	Power Supply for AMP
99	-	AL+5V	A/D, D/A Standard Voltage
100	-	NU	Not Used



# LEAD IDENTIFICATIONS

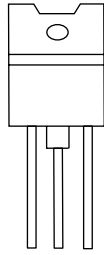
2SK2662



S D G

S: Source  
D: Drain  
G: Gate

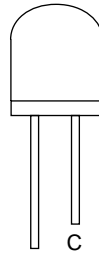
TT2140LS-YB11  
2SC5885000RF



B C E

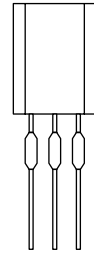
E: Emitter  
C: Collector  
B: Base

MID-32A22



E C

2SD400(F)

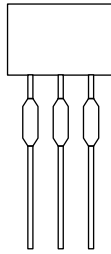


E C B

LA78040A  
AN5522

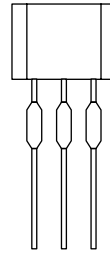


IN G OUT



E C B

KRA103M  
2SC1815-GR(TPE2)  
2SC3331(T,U)  
2SC2120-(O,Y)(TPE2)  
KTC3203(Y)  
KTA1266(GR)

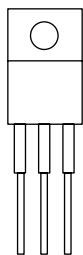


E C B

2SC1627Y-TPE2  
2SA950(Y,O)  
KTA1271(Y)  
2SC2482 TPE6  
2SC3468(E,D)-AE  
KTC3207  
2SA1175(F)  
KTA1267(GR)  
KTC3198(GR)

BN1F4M-T  
KTC3199(GR)  
2SC2785(J,H,F)  
2SA1015-GR(TPE2)

KIA7805API  
KA7805A  
AN7805F

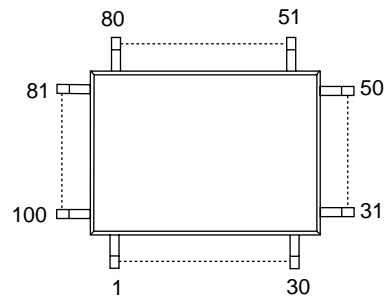


IN G OUT

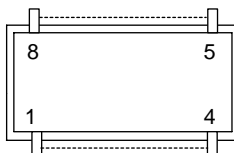
LTV-817(B,C)-F  
PC817X6



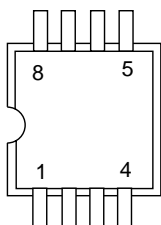
M37762M8A-8B1GP  
LA71091M



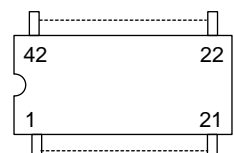
LA4224



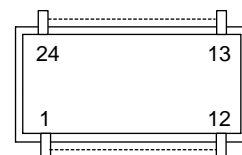
BR24C02F-W  
BR24C02F  
AT24C02-10SC  
M24C02-MN6  
CAT24WC02JI



M61275FP



M61111FP



# DECK MECHANISM SECTION

19" COLOR TV/VCR COMBINATION

C6319CD

**Sec. 2: Deck Mechanism Section**

- Standard Maintenance
- Alignment for Mechanism
- Disassembly/Assembly of Mechanism
- Alignment Procedures of Mechanism

## TABLE OF CONTENTS

Standard Maintenance . . . . .	2-1-1
Service Fixtures and Tools . . . . .	2-2-1
Mechanical Alignment Procedures . . . . .	2-3-1
Disassembly / Assembly Procedures of Deck Mechanism . . . . .	2-4-1
Alignment Procedures of Mechanism . . . . .	2-4-9

# STANDARD MAINTENANCE

## Service Schedule of Components

H: Hours ○ : Check ● : Change

Deck		Periodic Service Schedule			
Ref.No.	Part Name	1,000 H	2,000 H	3,000 H	4,000 H
B2	Cylinder Assembly	○	●	○	●
B3	Loading Motor Assembly			●	
B8	Pulley Assembly		●		●
B587	Tension Lever Assembly		●		●
B31	AC Head Assembly			●	
B573,B574	Reel (SP)(D2), Reel (TU)(D2)			●	
B37	Capstan Motor		●		●
B52	Cap Belt		●		●
*B73	FE Head			●	
B133,B134	Idler Gear, Idler Arm		●		●
B410	Pinch Arm Assembly		●		●
B414	M Brake (SP) Assembly		●		●
B416	M Brake (TU) Assembly		●		●
B525	LDG Belt		●		●
B569 (2 head only)	Cam Holder (F)		●		●
B593 (4 head, 4 head HiFi only)	Cam Holder (F) Assembly		●		●

### Notes:

- 1.Clean all parts for the tape transport (Upper Drum with Video Head / Pinch Roller / Audio Control Head / Full Erase Head) using 90% Isopropyl Alcohol.
  - 2.After cleaning the parts, do all DECK ADJUSTMENTS.
  - 3.For the reference numbers listed above, refer to Deck Exploded Views.
- \* B73 ----- Recording Model only

## Cleaning

### Cleaning of Video Head

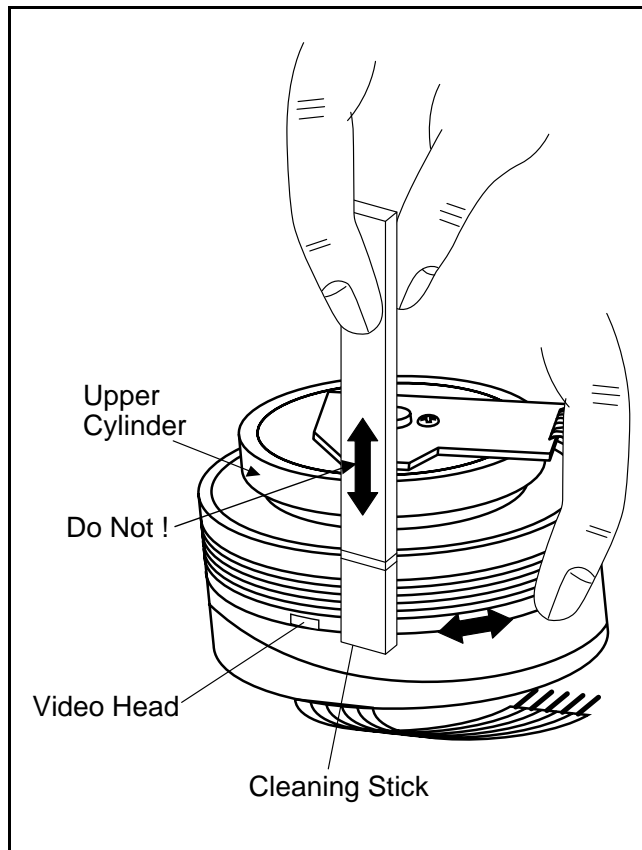
Clean the head with a head cleaning stick or chamois cloth.

#### Procedure

1. Remove the top cabinet.
2. Put on a glove (thin type) to avoid touching the upper and lower drum with your bare hand.
3. Put a few drops of 90% Isopropyl alcohol on the head cleaning stick or on the chamois cloth and, by slightly pressing it against the head tip, turn the upper drum to the right and to the left.

#### Notes:

1. The video head surface is made of very hard material, but since it is very thin, avoid cleaning it vertically.
2. Wait for the cleaned part to dry thoroughly before operating the unit.
3. Do not reuse a stained head cleaning stick or a stained chamois cloth.



### Cleaning of Audio Control Head

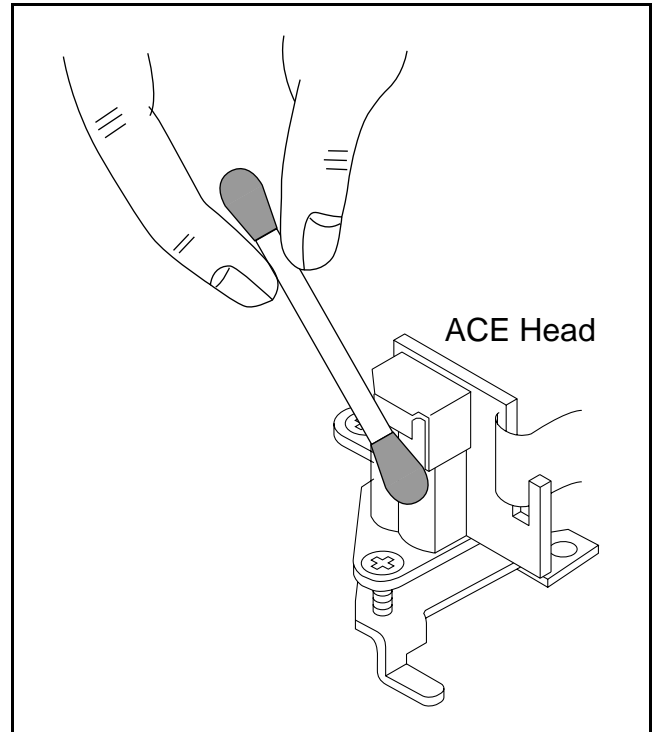
Clean the head with a cotton swab.

#### Procedure

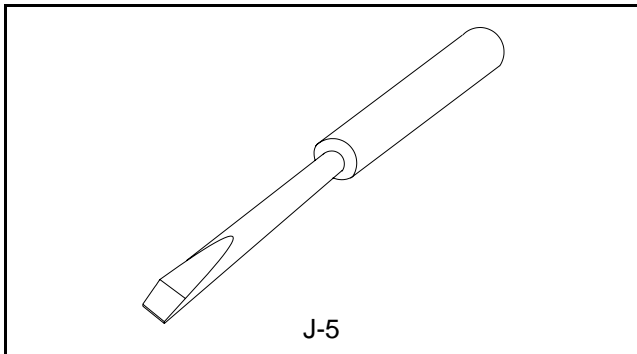
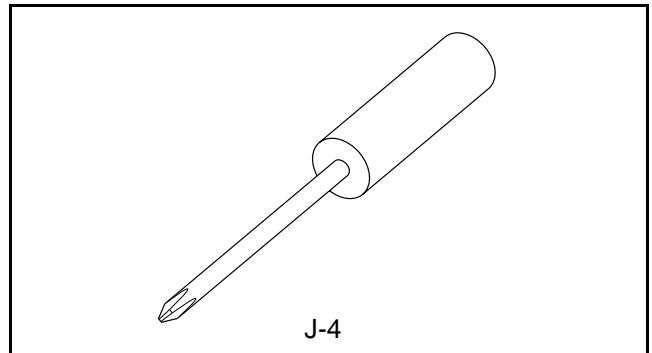
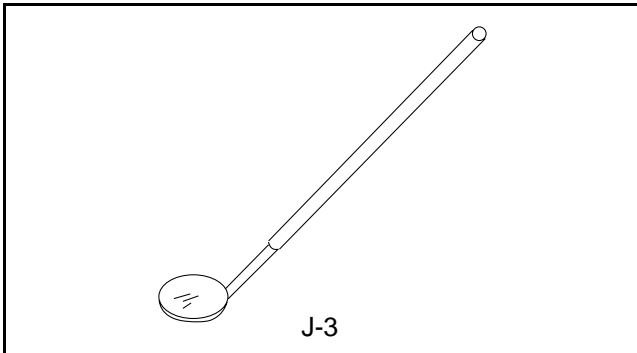
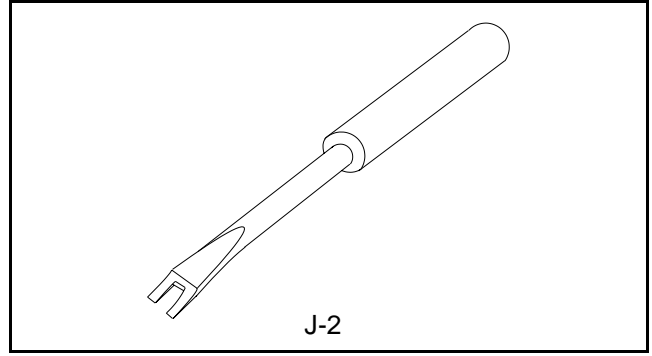
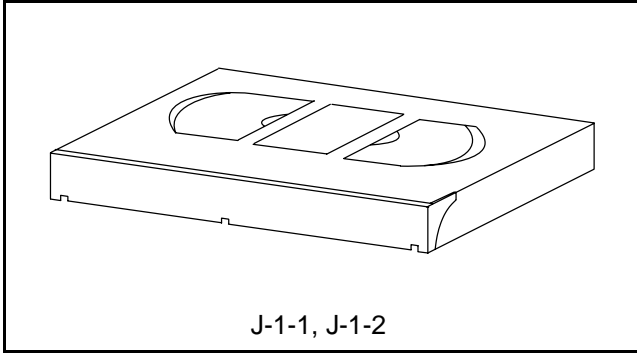
1. Remove the top cabinet.
2. Dip the cotton swab in 90% isopropyl alcohol and clean the audio control head. Be careful not to damage the upper drum and other tape running parts.

#### Notes:

1. Avoid cleaning the audio control head vertically.
2. Wait for the cleaned part to dry thoroughly before operating the unit or damage may occur.



# SERVICE FIXTURE AND TOOLS



Ref. No.	Name	Part No.	Adjustment
J-1-1	Alignment Tape	FL8A	Head Adjustment of Audio Control Head
J-1-2	Alignment Tape	FL8N (2Head only) FL8NW (4Head only)	Azimuth and X Value Adjustment of Audio Control Head / Adjustment of Envelope Waveform
J-2	Guide Roller Adj.Screwdriver	Available Locally	Guide Roller
J-3	Mirror	Available Locally	Tape Transportation Check
J-4	Azimuth Adj.Screwdriver +	Available Locally	A/C Head Height
J-5	X Value Adj.Screwdriver -	Available Locally	X Value

# MECHANICAL ALIGNMENT PROCEDURES

Explanation of alignment for the tape to correctly run starts on the next page. Refer to the information below on this page if a tape gets stuck, for example, in the mechanism due to some electrical trouble of the unit.

## Service Information

### A. Method for Manual Tape Loading/Unloading

To load a cassette tape manually:

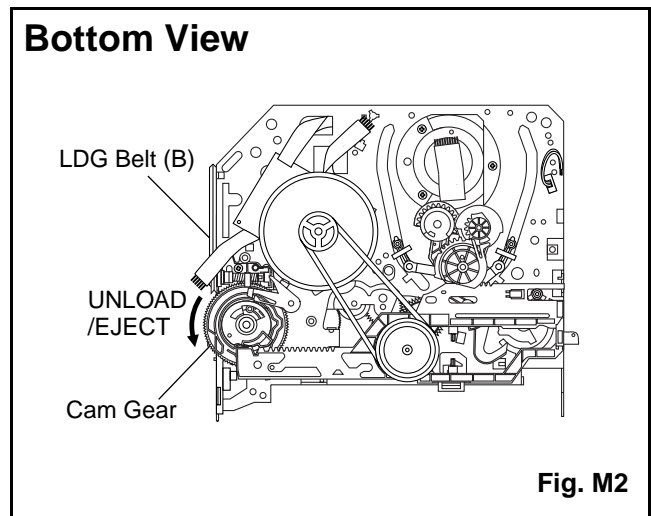
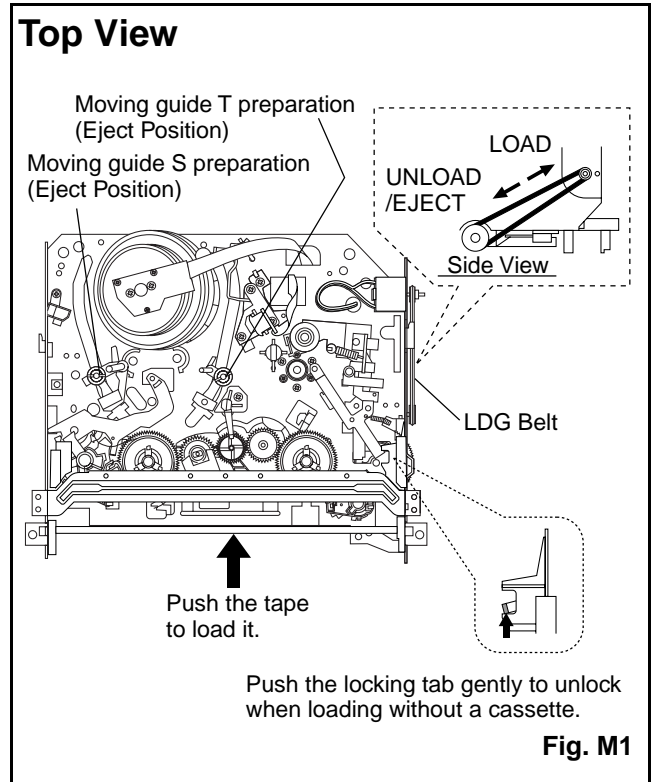
1. Disconnect the AC plug.
2. Remove the Top Case and Front Assembly.
3. Insert a cassette tape. Though the tape will not be automatically loaded, make sure that the cassette tape is all the way in at the inlet of the Cassette Holder. To confirm this, lightly push the cassette tape further in and see if the tape comes back out, by a spring motion, just as much as you have pushed in.
4. Turn the LDG Belt in the appropriate direction shown in Fig. M1 for a minute or two to complete this task.

To unload a cassette tape manually:

1. Disconnect the AC plug.
2. Remove the Top Case and Front Assembly.
3. Make sure that the Moving guide preparations are in the Eject Position.
4. Turn the LDG Belt in the appropriate direction shown in Fig. M1 until the Moving guide preparations come to the Eject Position. Stop turning when the preparations begin clicking or can not be moved further. However, the tape will be left wound around the cylinder.
5. Turn the LDG Belt in the appropriate direction continuously, and the cassette tape will be ejected. Allow a minute or two to complete this task.

### B. Method to place the Cassette Holder in the tape-loaded position without a cassette tape

1. Disconnect the AC Plug.
2. Remove the Top Case and Front Assembly.
3. Turn the LDG Belt in the appropriate direction shown in Fig. M1. Release the locking tabs shown in Fig. M1 and continue turning the LDG Belt until the Cassette Holder comes to the tape-loaded position. Allow a minute or two to complete this task.



# 1. Tape Interchangeability Alignment

Note:

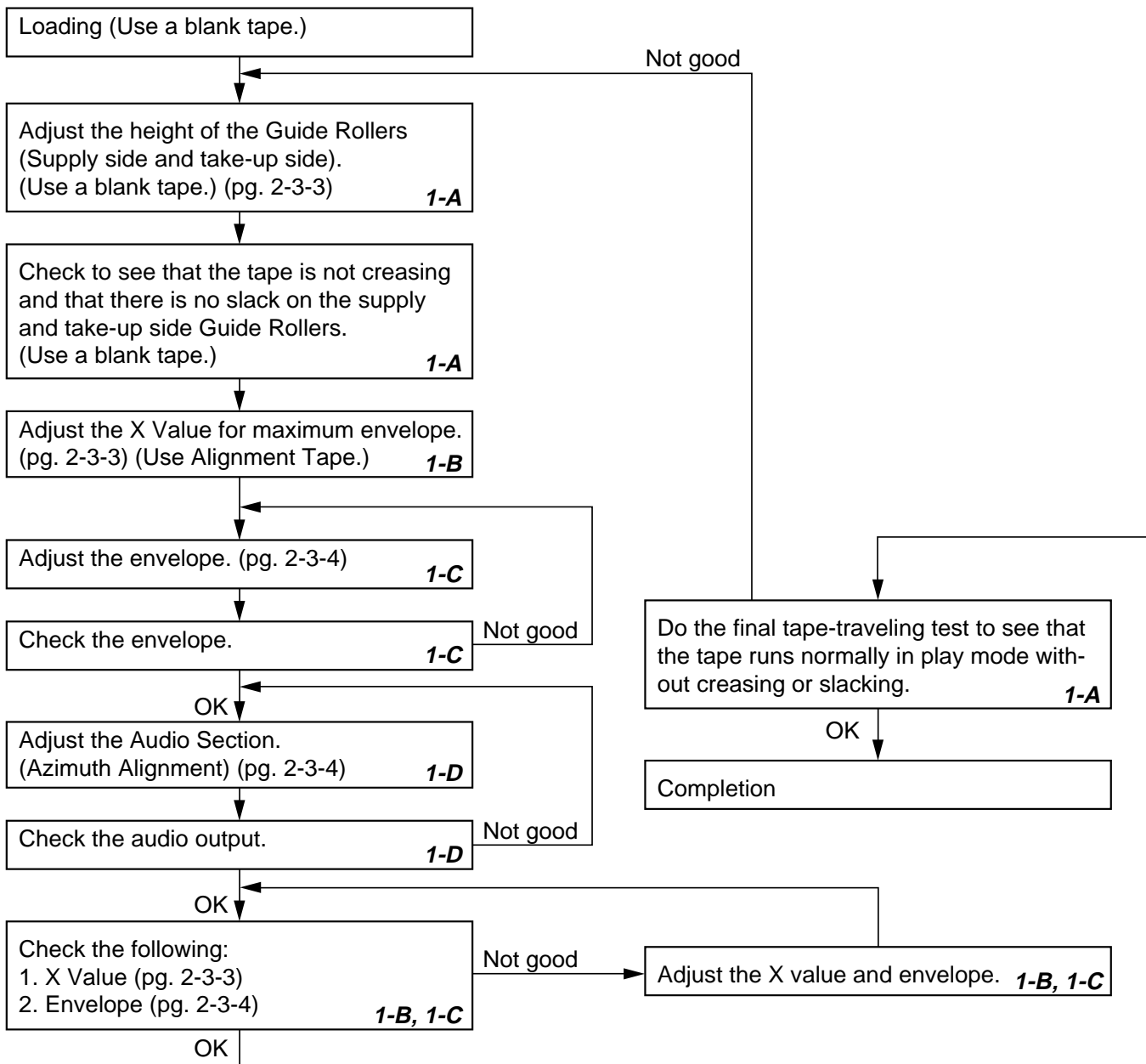
To do these alignment procedures, make sure that the Tracking Control Circuit is set to the center position every time a tape is loaded or unloaded. (Refer to page 2-3-4, procedure 1-C, step 2.)

## Equipment required:

- Dual Trace Oscilloscope
- VHS Alignment Tape (FL8N)
- Guide Roller Adj. Screwdriver
- X-Value Adj. Screwdriver

Note: Before starting this Mechanical Alignment, do all Electrical Adjustment procedures.

## Flowchart of Alignment for tape traveling



## 1-A. Preliminary/Final Checking and Alignment of Tape Path

### Purpose:

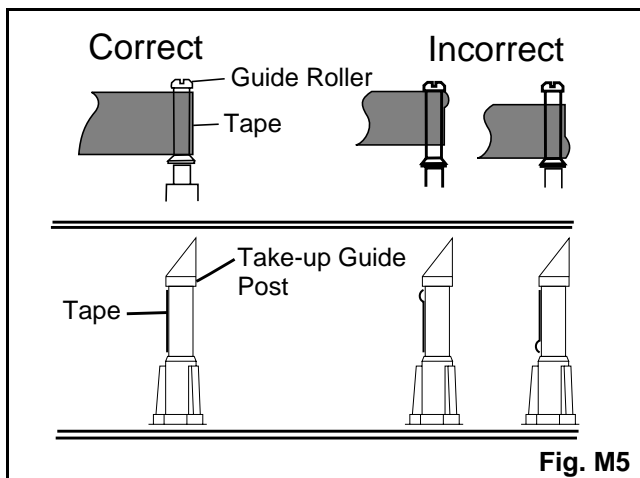
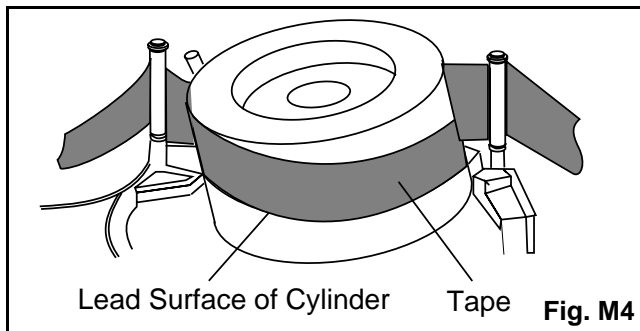
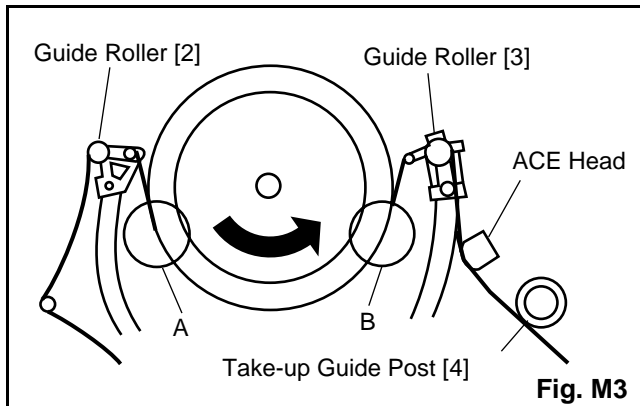
To make sure that the tape path is well stabilized.

### Symptom of Misalignment:

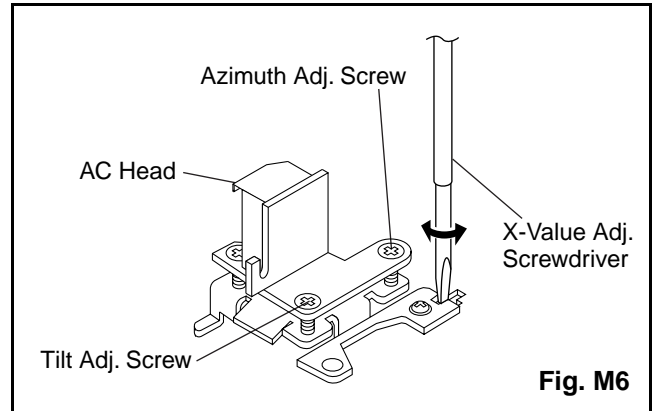
If the tape path is unstable, the tape will be damaged.

**Note:** Do not use an Alignment Tape for this procedure. If the unit is not correctly aligned, the tape may be damaged.

1. Playback a blank cassette tape and check to see that the tape runs without creasing at Guide Rollers [2] and [3], and at points A and B on the lead surface. (Refer to Fig. M3 and M4.)
2. If creasing is apparent, align the height of the guide rollers by turning the top of Guide Rollers [2] and [3] with a Guide Roller Adj. Screwdriver. (Refer to Fig. M3 and M5.)



3. Check to see that the tape runs without creasing at Take-up Guide Post [4] or without snaking between Guide Roller [3] and AC Head. (Fig. M3 and M5)
4. If creasing or snaking is apparent, adjust the Tilt Adj. Screw of the AC Head. (Fig. M6)



## 1-B. X Value Alignment

### Purpose:

To align the Horizontal Position of the Audio/Control/ Erase Head.

### Symptom of Misalignment:

If the Horizontal Position of the Audio/Control/Erase Head is not properly aligned, maximum envelope cannot be obtained at the Neutral position of the Tracking Control Circuit.

1. Connect the oscilloscope to TP402 (ENV.) and TP201 (CTL) on the Main CBA. Use J274 (RF-SW) as a trigger.
2. Playback the Gray Scale of the Alignment Tape (FL8N) and confirm that the PB FM signal is present.
3. Set the Tracking Control Circuit to the center position by pressing CH UP button then "PLAY" button on the unit. (Refer to note on bottom of page 2-3-4.)
4. Use the X-Value Adj. Screwdriver so that the PB FM signal at TP402 (ENV.) is maximum. (Fig. M6)
5. Press CH UP button on the unit until the CTL waveform has shifted by approx. +2msec. Make sure that the envelope is simply attenuated (shrinks in height) during this process so that you will know the envelope has been at its peak.



- Press CH DOWN button on the unit until the CTL waveform has shifted from its original position (not the position achieved in step 5, but the position of CTL waveform in step 4) by approximately -2msec. Make sure that the envelope is simply attenuated (shrinks in height) once CTL waveform passes its original position and is further brought in the minus direction.
- Set the Tracking Control Circuit to the center position by pressing CH UP button and then "PLAY" button.

### 1-C. Checking/Adjustment of Envelope Waveform

**Purpose:**

To achieve a satisfactory picture and precise tracking.

**Symptom of Misalignment:**

If the envelope output is poor, noise will appear in the picture. The tracking will then lose precision and the playback picture will be distorted by any slight variation of the Tracking Control Circuit.

- Connect the oscilloscope to TP402 (ENV.) on the Main CBA. Use J274 (RF-SW) as a trigger.
- Playback the Gray Scale on the Alignment Tape (FL8N). Set the Tracking Control Circuit to the center position by pressing CH UP button and then "PLAY" button on the unit. Adjust the height of Guide Rollers [2] and [3] (Fig. M3, Page 2-3-3) watching the oscilloscope display so that the envelope becomes as flat as possible. To do this adjustment, turn the top of the Guide Roller with the Guide Roller Adj. Screwdriver.
- If the envelope is as shown in Fig. M7, adjust the height of Guide Roller [2] (Refer to Fig. M3) so that the waveform looks like the one shown in Fig. M9.
- If the envelope is as shown in Fig. M8, adjust the height of Guide Roller [3] (Refer to Fig. M3) so that the waveform looks like the one shown in Fig. M9.
- When Guide Rollers [2] and [3] (Refer to Fig.M3) are aligned properly, there is no envelope drop either at the beginning or end of track as shown in Fig. M9.

Note: Upon completion of the adjustment of Guide Rollers [2] and [3] (Refer to Fig. M3), check the X Value by pushing the CH UP or DOWN buttons alternately, to check the symmetry of the envelope. Check the number of pushes to ensure center position. The number of pushes CH UP button to achieve 1/2 level of envelope should match the number of pushes CH DOWN button from center. If required, redo the "X Value Alignment."

### 1-D. Azimuth Alignment of Audio/Control/ Erase Head

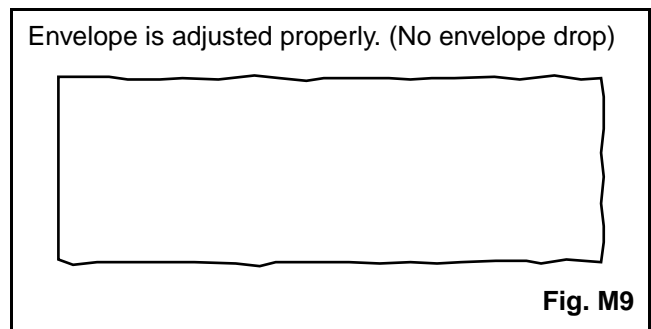
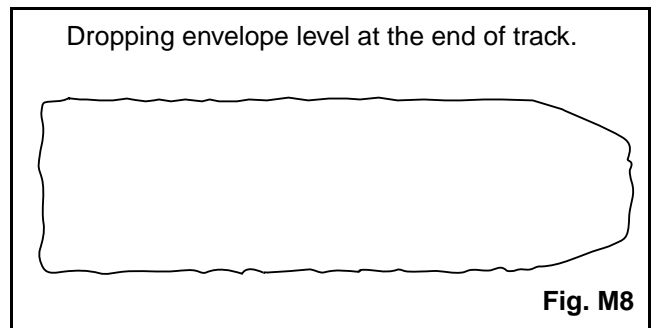
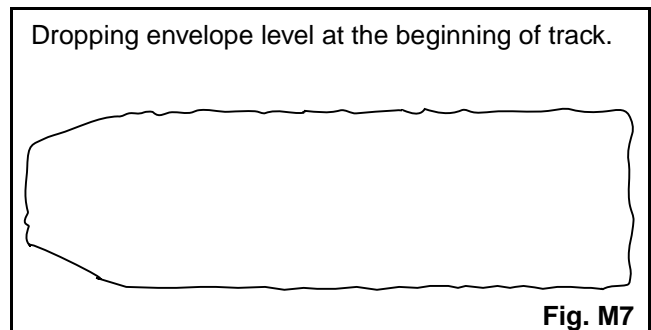
**Purpose:**

To correct the Azimuth alignment so that the Audio/Control/Erase Head meets tape tracks properly.

**Symptom of Misalignment:**

If the position of the Audio/Control/Erase Head is not properly aligned, the Audio S/N Ratio or Frequency Response will be poor.

- Connect the oscilloscope to the audio output jack on the rear side of the deck.
- Playback the alignment tape (FL8N) and confirm that the audio signal output level is 8kHz.
- Adjust Azimuth Adj. Screw so that the output level on the AC Voltmeter or the waveform on the oscilloscope is at maximum. (Fig. M6)



# DISASSEMBLY/ASSEMBLY PROCEDURES OF DECK MECHANISM

Before following the procedures described below, be sure to remove the deck assembly from the cabinet. (Refer to CABINET DISASSEMBLY INSTRUCTIONS on page 1-6-1.)

All the following procedures, including those for adjustment and replacement of parts, should be done in Eject mode; see the positions of [41] and [42] in Fig.DM1 on page 2-4-3. When reassembling, follow the steps in reverse order.

STEP /LOC. No.	START-ING No.	PART		REMOVAL		INSTALLATION
				Fig. No.	REMOVE/*UNHOOK/ UNLOCK/RELEASE/ UNPLUG/DESOLDER	ADJUSTMENT CONDITION
[1]	[1]	Guide Holder A	T	DM3	2(S-1)	
[2]	[1]	Cassette Holder Assembly	T	DM4		
[3]	[2]	Slider (SP)	T	DM5	*(L-1)	
[4]	[2]	Slider (TU)	T	DM5	*(L-2)	
[5]	[4]	Lock Lever	T	DM5	*(L-3), *(P-1)	
[6]	[2]	Cassette Plate	T	DM5	(S-1A)	
[7]	[7]	Cylinder Assembly	T	DM1,DM6	Desolder, 3(S-2)	
[8]	[8]	Loading Motor Assembly	T	DM1,DM7	Desolder, LDG Belt, 2(S-3)	
[9]	[9]	AC Head Assembly	T	DM1,DM7	(S-4)	
[10]	[2]	Tape Guide Arm Assembly	T	DM1,DM8	*(P-2)	
[11]	[10]	C Door Opener	T	DM1,DM8	*(L-4)	
[12]	[11]	Pinch Arm (B)	T	DM1,DM8	*(P-3)	
[13]	[12]	Pinch Arm Assembly	T	DM1,DM8		
[14]	[14]	FE Head Assembly	T	DM1,DM9	(S-5)	
[15]	[15]	Prism	T	DM1,DM9	(S-6)	
[16]	[2],[15]	Sensor Gear	T	DM1,DM15		
[17]	[2]	Slider Shaft	T	DM10	*(L-5)	
[18]	[17]	C Drive Lever (SP)	T	DM10		
[19]	[17]	C Drive Lever (TU)	T	DM10	(S-7), *(P-4)	
[20]	[7],[8], [10]	Capstan Motor	B	DM2,DM11	3(S-8), Cap Belt	
[21]	[21]	Clutch Assembly	B	DM2,DM12	(C-1)	
[22]	[22]	Cam Holder (F)	B	DM2,DM12	*(L-6)	
[23]	[23]	Cam Gear (B)	B	DM2,DM12	(C-4), *(P-5)	
[24]	[24]	Mode Gear	B	DM2,DM13	(C-2)	
[25]	[21],[23], [24]	Mode Lever	B	DM2,DM13	(C-3), *(L-8)	
[26]	[22]	Worm Holder	B	DM2,DM13	(S-9), *(L-9), *(L-10)	
[27]	[26]	Pulley Assembly	B	DM2,DM13		
[28]	[25],[26]	Cam Gear (A)	B	DM2,DM13		
[29]	[25]	Idler Gear	B	DM1,DM14		
[30]	[29]	Idler Arm	B	DM1,DM14	*(L-11)	
[31]	[25]	BT Arm	B	DM2,DM14	*(P-6)	
[32]	[25]	Loading Arm (SP) Assembly	B	DM2,DM14		(+)Refer to Alignment Sec.Pg.2-4-9

STEP /LOC. No.	START-ING No.	PART		REMOVAL		INSTALLATION
				Fig. No.	REMOVE/*UNHOOK/ UNLOCK/RELEASE/ UNPLUG/DESOLDER	ADJUSTMENT CONDITION
[33]	[32]	Loading Arm (TU) Assembly	B	DM2,DM14		(+)Refer to Alignment Sec.Pg.2-4-9
[34]	[2],[25]	M Brake (TU) Assembly	T	DM1,DM15	*(P-7), Brake Belt	
[35]	[2],[25]	M Brake (SP) Assembly	T	DM1,DM15	*(P-8)	
[36]	[35]	Tension Lever Assembly	T	DM1,DM15		
[37]	[36]	T Lever Holder	T	DM15	*(L-12)	
[38]	[34]	Reel (TU)(D2)	T	DM1,DM15		
[39]	[38]	M Gear	T	DM1,DM15		
[40]	[36]	Reel (SP)(D2)	T	DM1,DM15		
[41]	[32],[36]	Moving Guide S Preparation	T	DM1,DM16		
[42]	[33]	Moving Guide T Preparation	T	DM1,DM16		
[43]	[19]	TG Post Assembly	T	DM1,DM16	*(L-13)	
[44]	[28]	Rack Assembly	R	DM17		(+)Refer to Alignment Sec.Pg.2-4-9
[45]	[44]	F Door Opener	R	DM17	*(P-9)	
[46]	[46]	Cleaner Assembly	T	DM1,DM6		
[47]	[46]	CL Post	T	DM6	*(L-14)	
↓ (1)	↓ (2)	↓ (3)	↓ (4)	↓ (5)	↓ (6)	↓ (7)

(1): Follow steps in sequence. When reassembling, follow the steps in reverse order.

These numbers are also used as identification (location) No. of parts in the figures.

(2): Indicates the part to start disassembling with in order to disassemble the part in column (1).

(3): Name of the part

(4): Location of the part: T=Top B=Bottom R=Right L=Left

(5): Figure Number

(6): Identification of parts to be removed, unhooked, unlocked, released, unplugged, unclamped, or desoldered.

P=Spring, W=Washer, C=Cut Washer, S=Screw, \*=Unhook, Unlock, Release, Unplug, or Desolder

e.g., 2(L-2) = two Locking Tabs (L-2).

(7): Adjustment Information for Installation

(+):Refer to Deck Exploded Views for lubrication.

# Top View

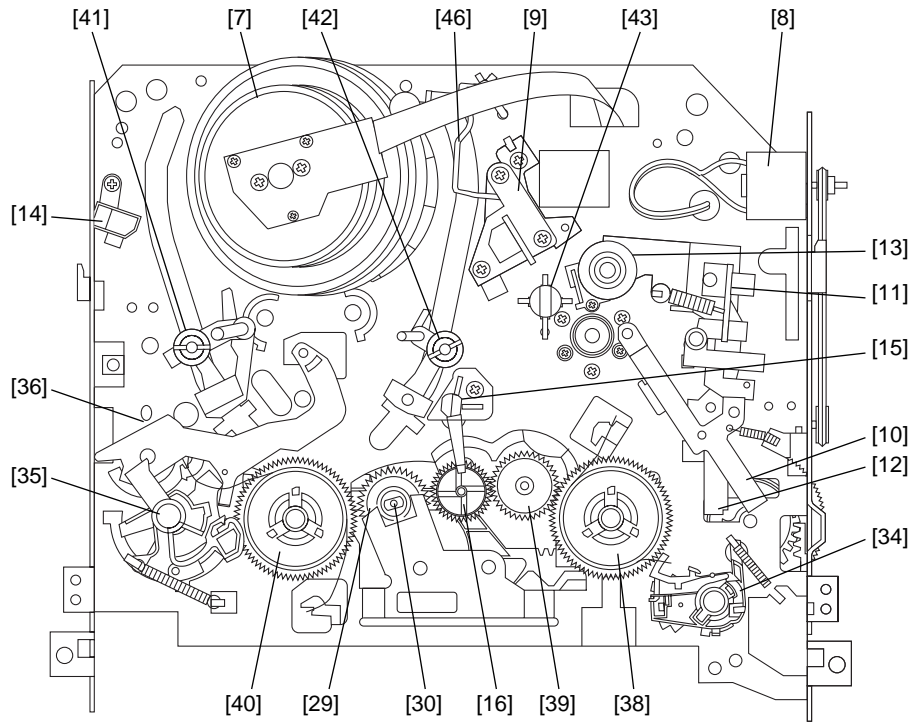


Fig. DM1

# Bottom View

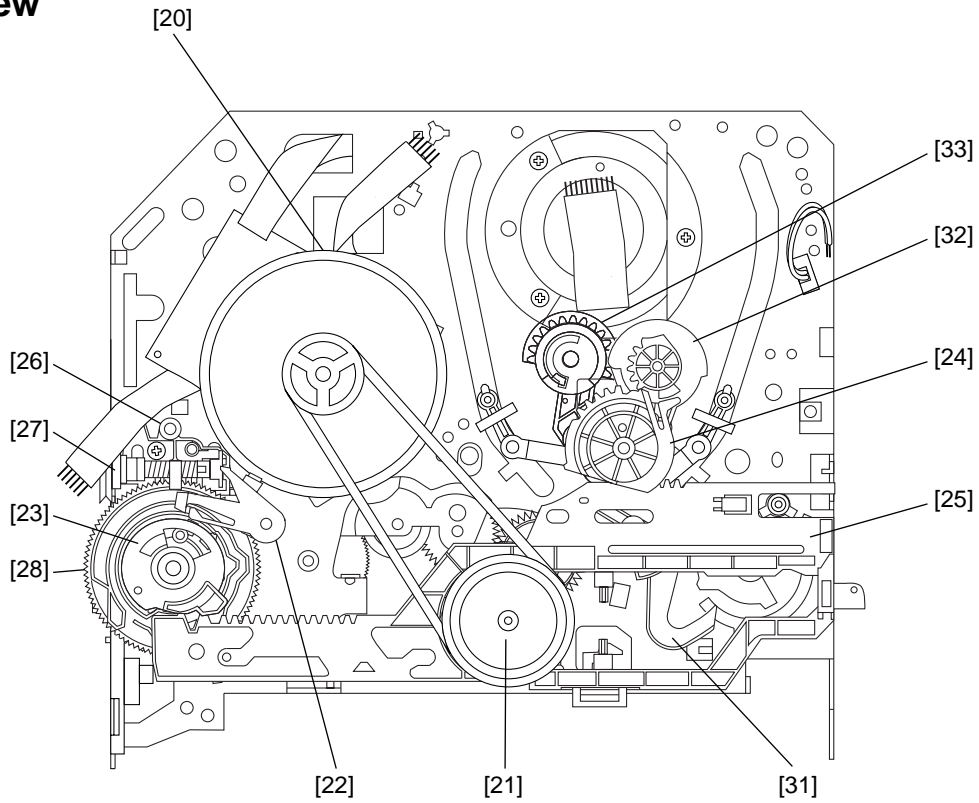
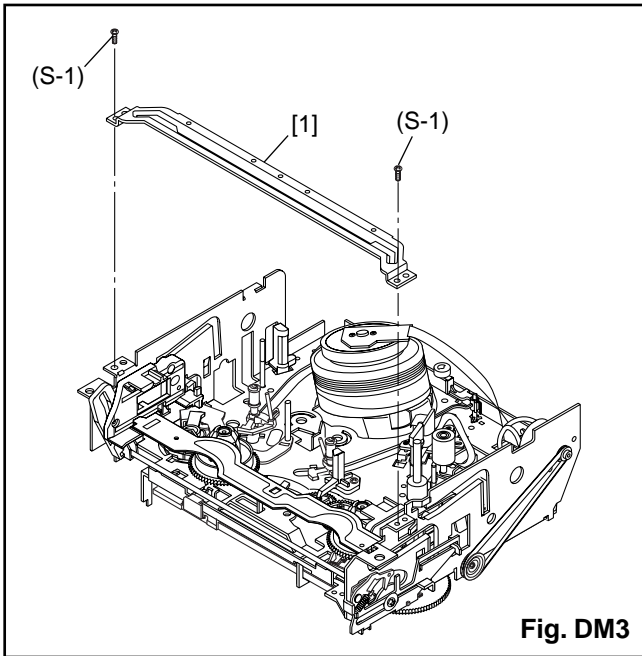
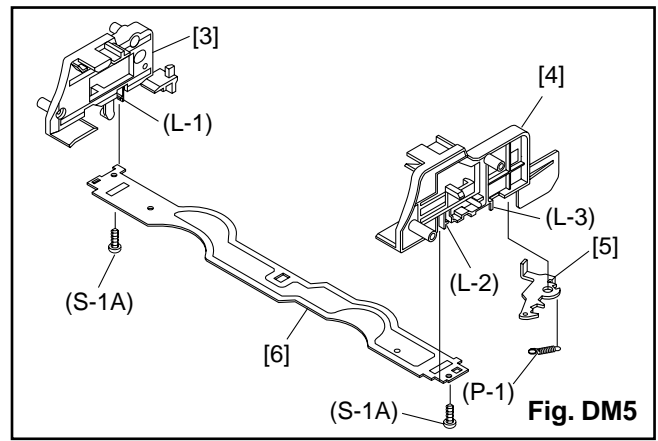


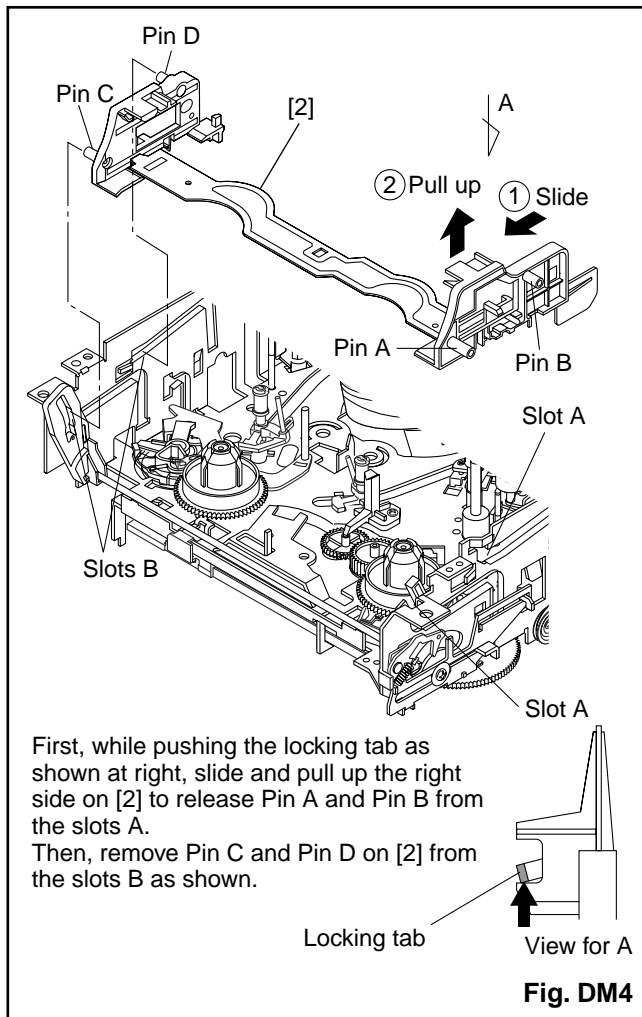
Fig. DM2



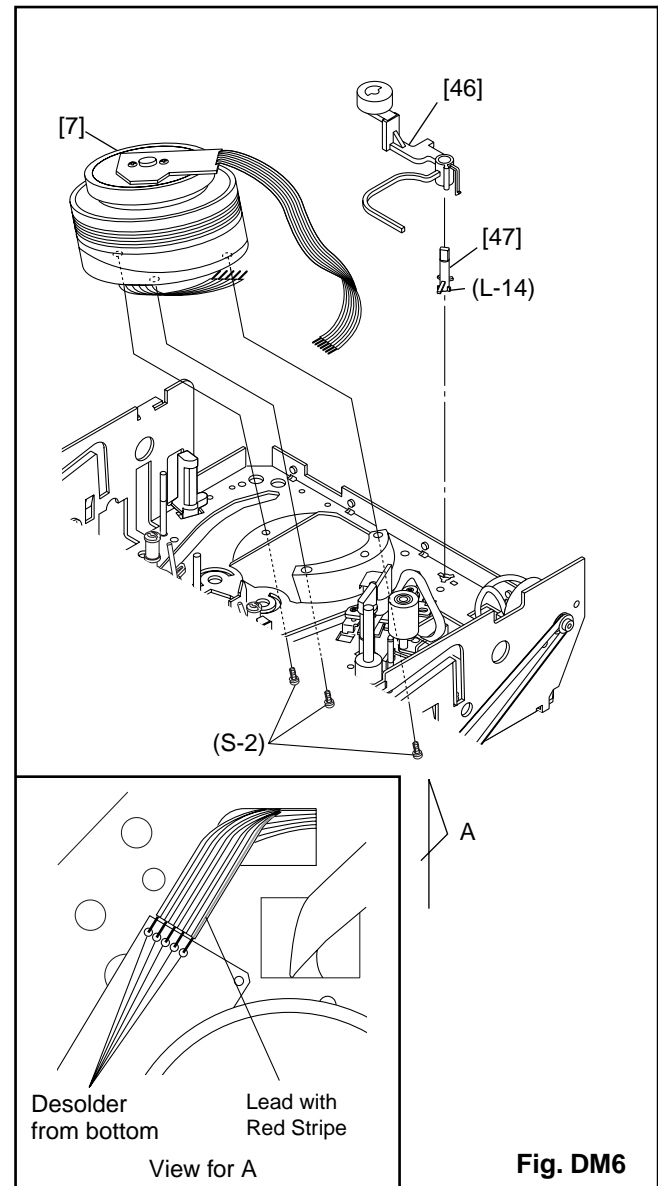
**Fig. DM3**



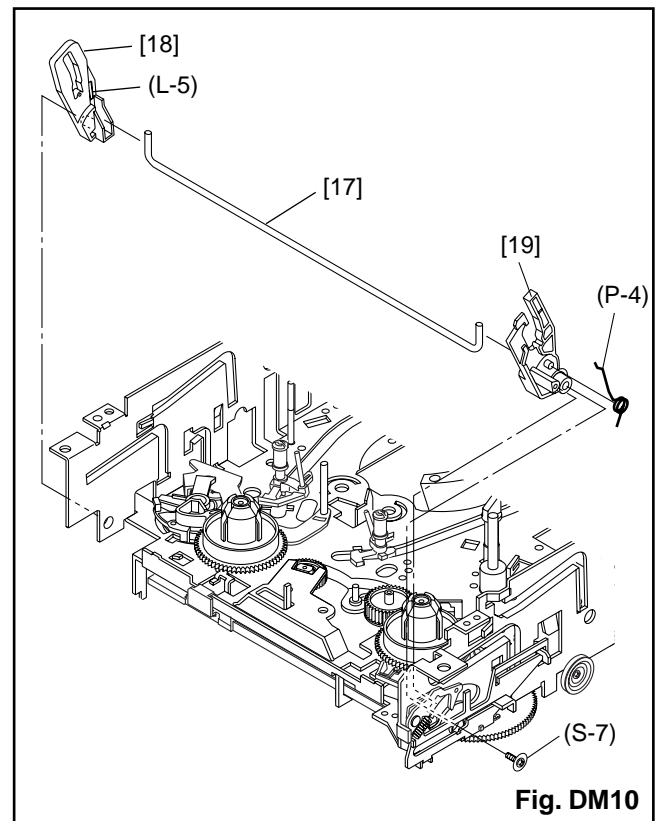
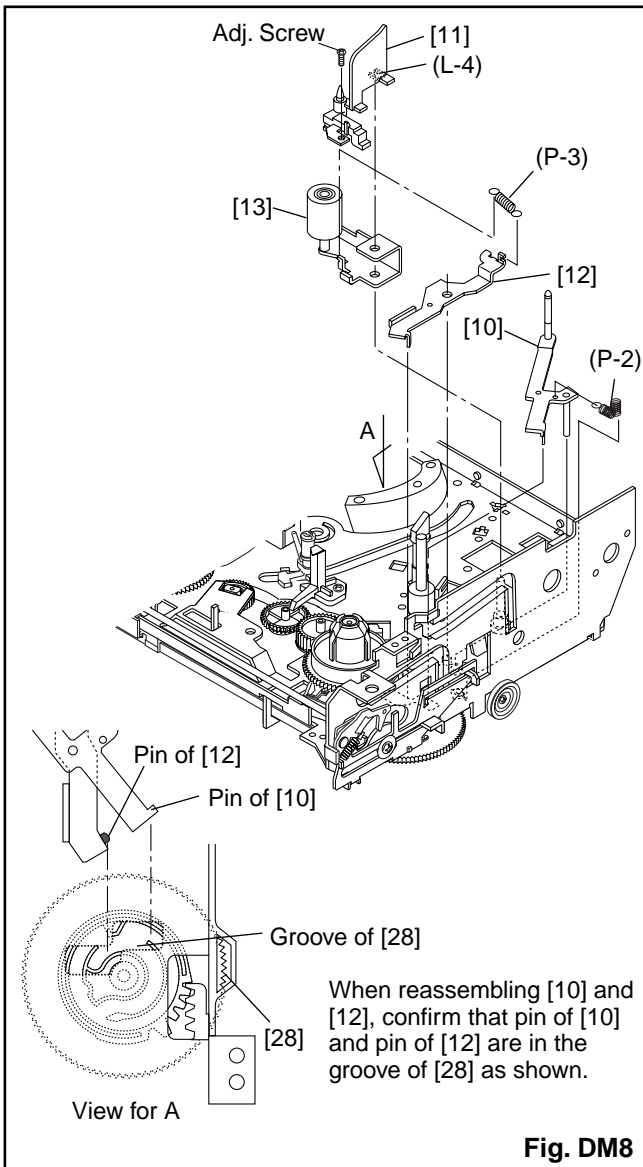
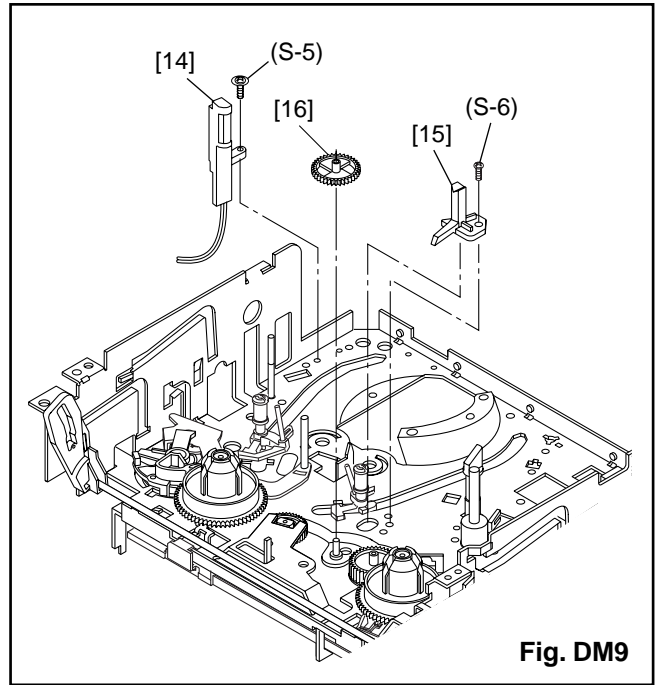
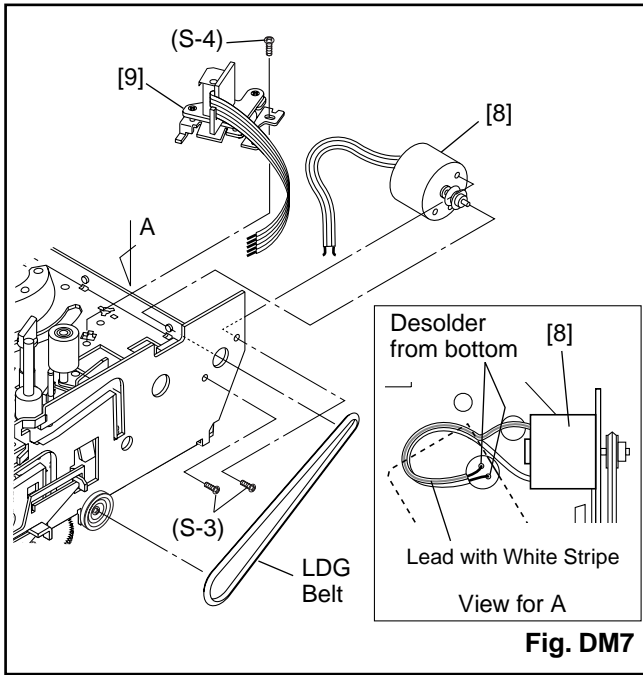
**Fig. DM5**

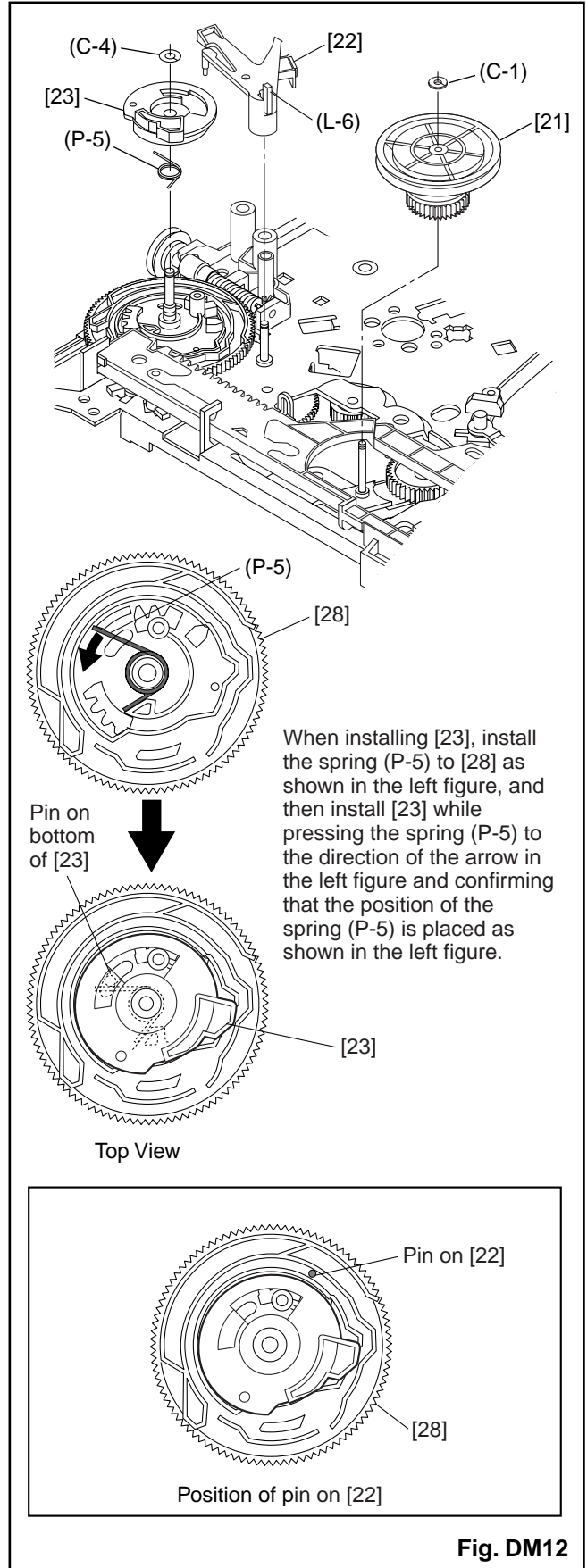
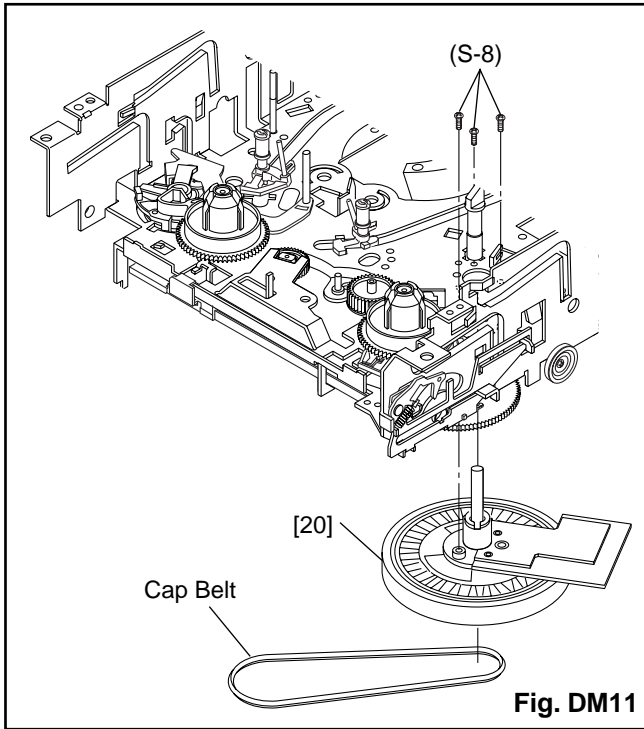


**Fig. DM4**

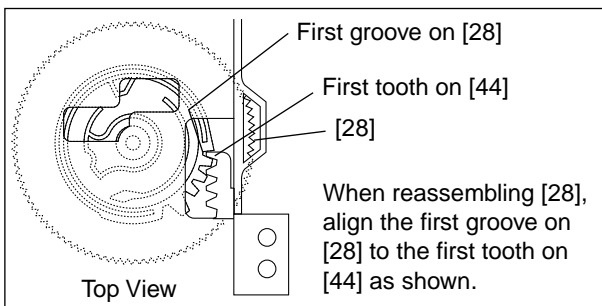
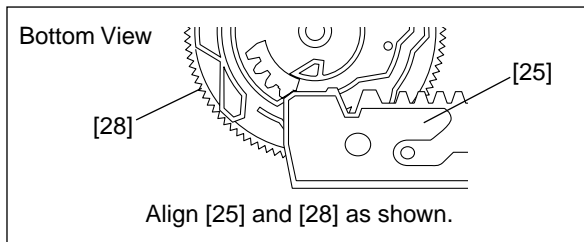
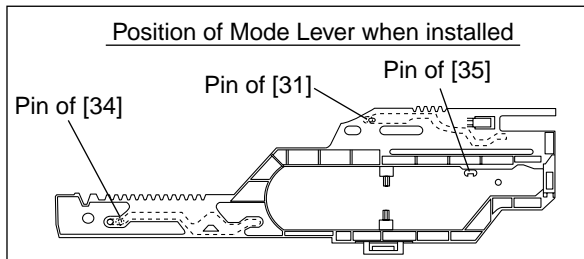
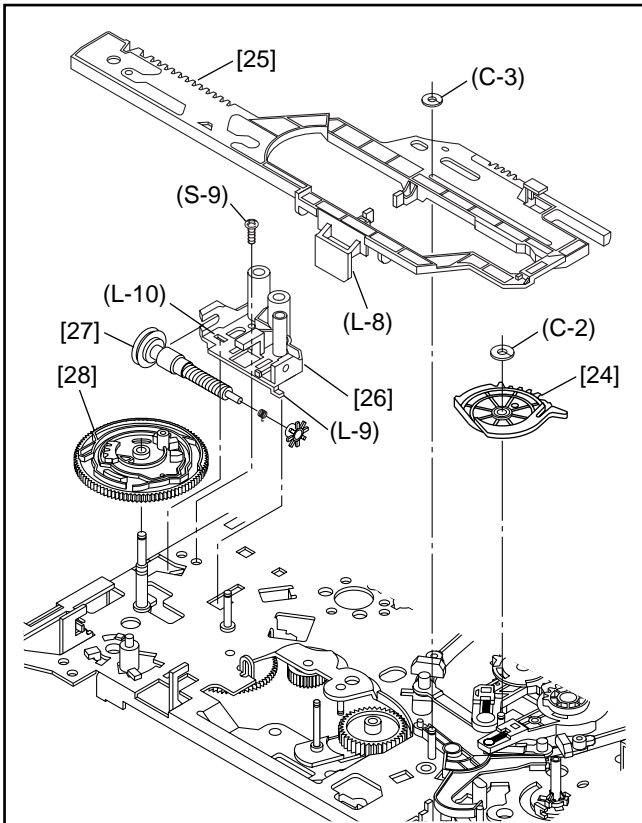


**Fig. DM6**

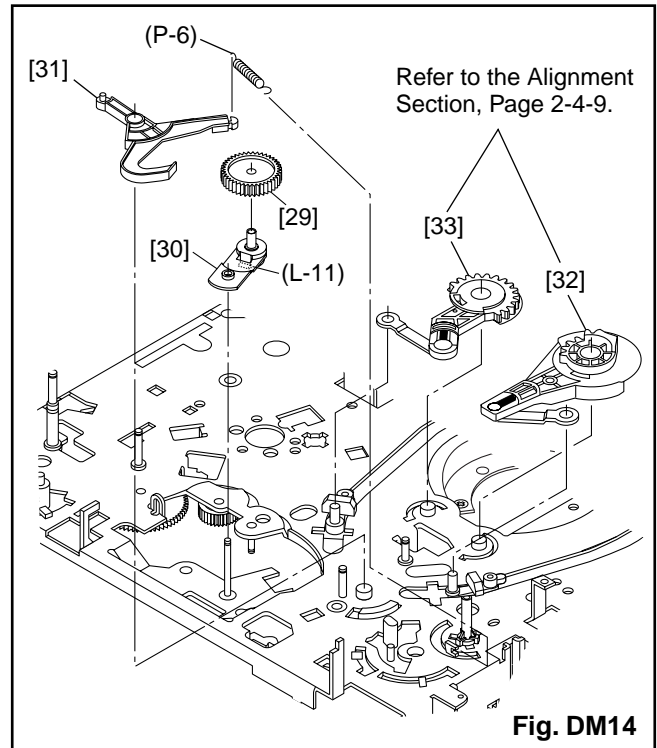




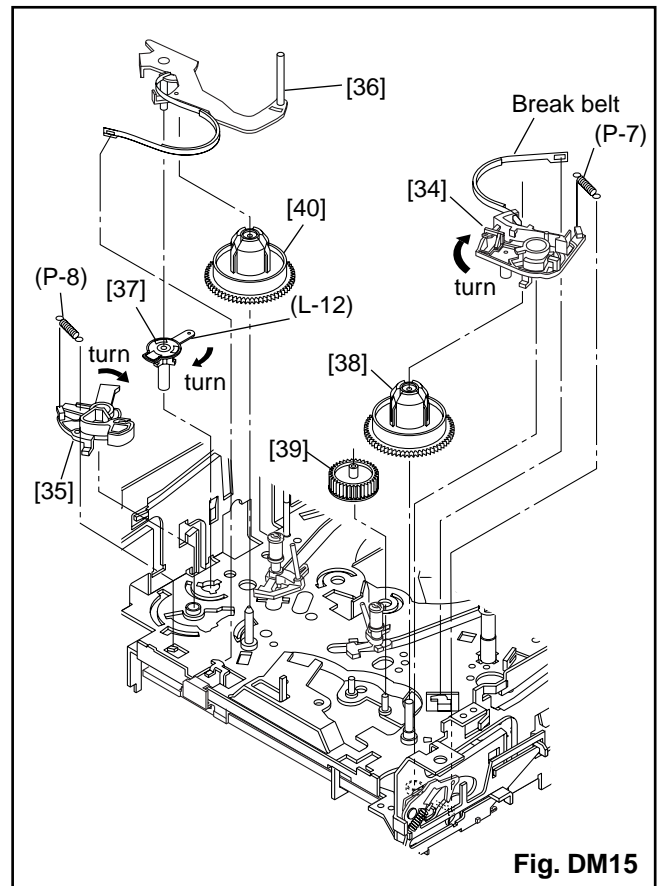




**Fig. DM13**

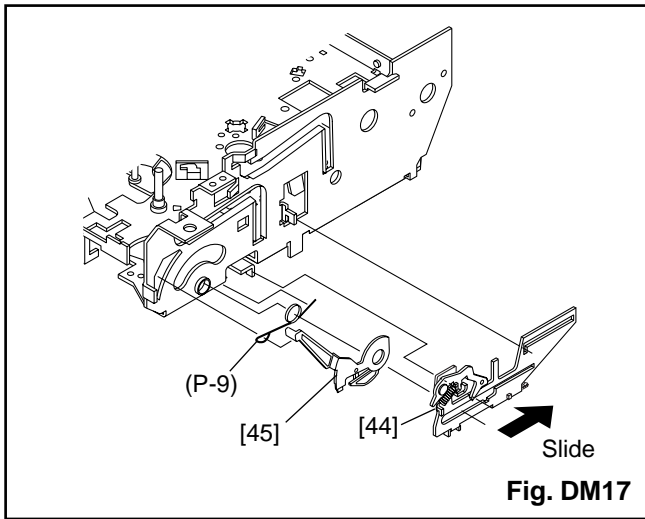
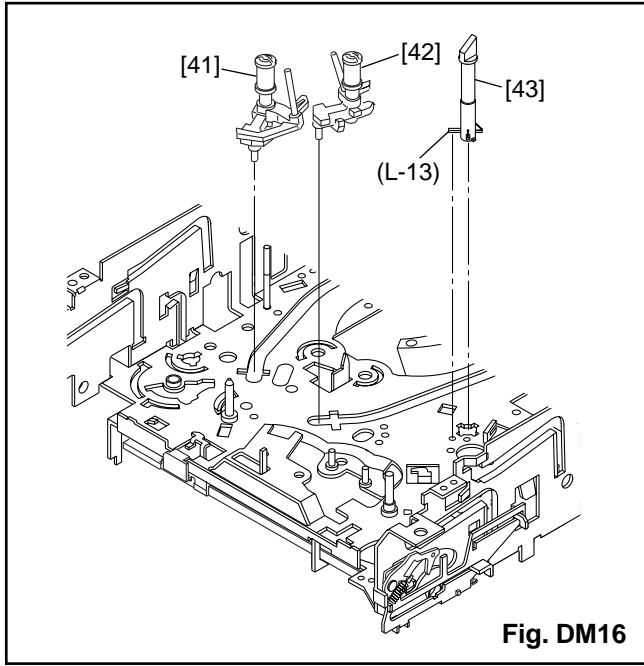


**Fig. DM14**



**Fig. DM15**





# ALIGNMENT PROCEDURES OF MECHANISM

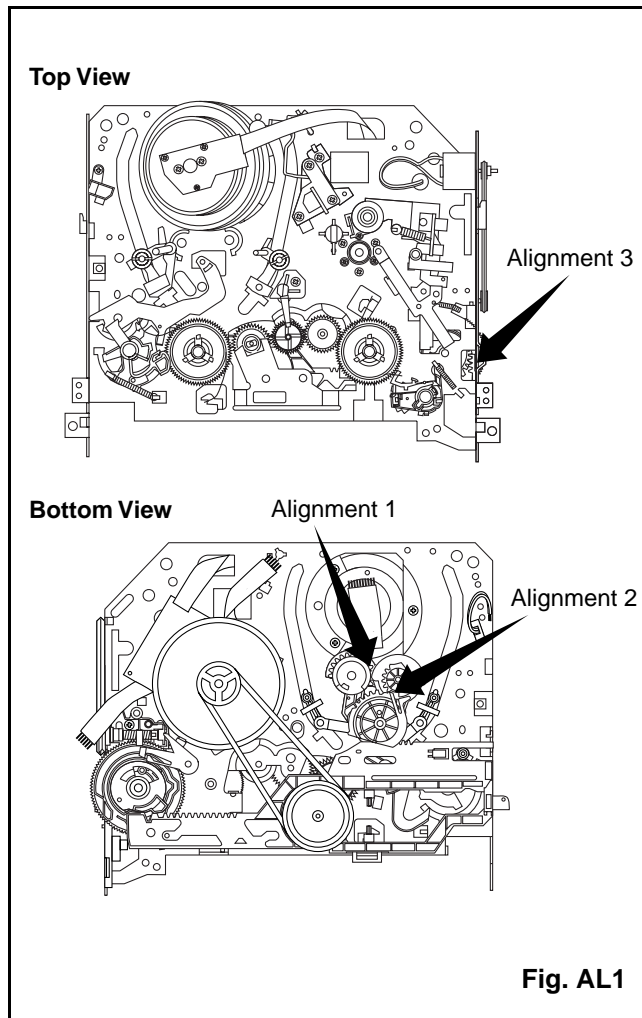
The following procedures describe how to align the individual gears and levers that make up the tape loading/unloading mechanism. Since information about the state of the mechanism is provided to the System Control Circuit only through the Mode Switch, it is essential that the correct relationship between individual gears and levers be maintained.

**All alignments are to be performed with the mechanism in Eject mode**, in the sequence given. Each procedure assumes that all previous procedures have been completed.

## IMPORTANT:

If any one of these alignments is not performed properly, even if off by only one tooth, the unit will unload or stop and it may result in damage to the mechanical or electrical parts.

## Alignment points in Eject Position



## Alignment 1

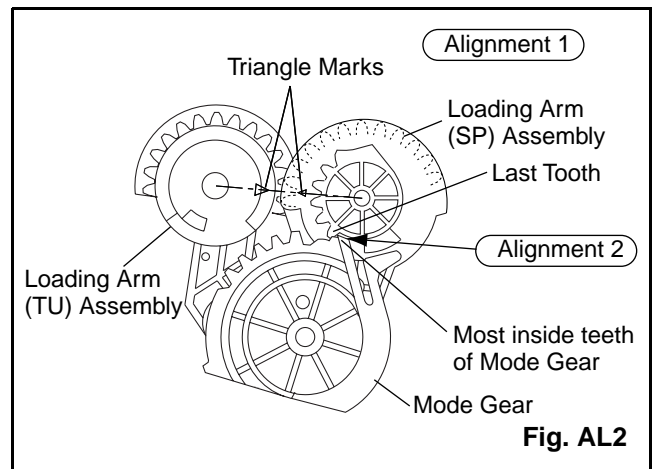
### Loading Arm (SP) and (TU) Assembly

Install Loading Arm (SP) and (TU) Assembly so that their triangle marks point to each other as shown in Fig. AL2.

## Alignment 2

### Mode Gear

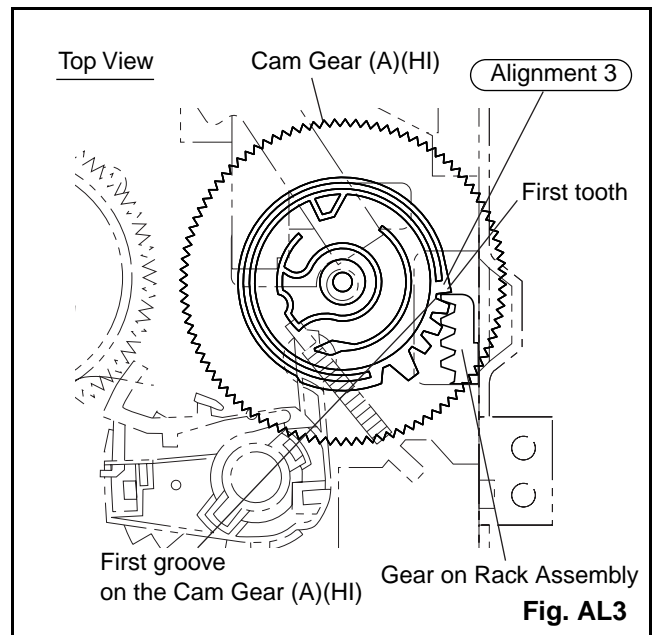
Keeping the two triangles pointing at each other, install the Loading Arm (SP) Assembly so that the last tooth of the gear meets the most inside teeth of the Mode Gear. See Fig. AL2.



## Alignment 3

### Cam Gear (A), Rack Assembly

Install the Rack Assembly so that the first tooth on the gear of the Rack Assembly meets the first groove on the Cam Gear (A) as shown in Fig. AL3.



# EXPLODED VIEWS AND PARTS LIST SECTION

19" COLOR TV/VCR COMBINATION

C6319CD

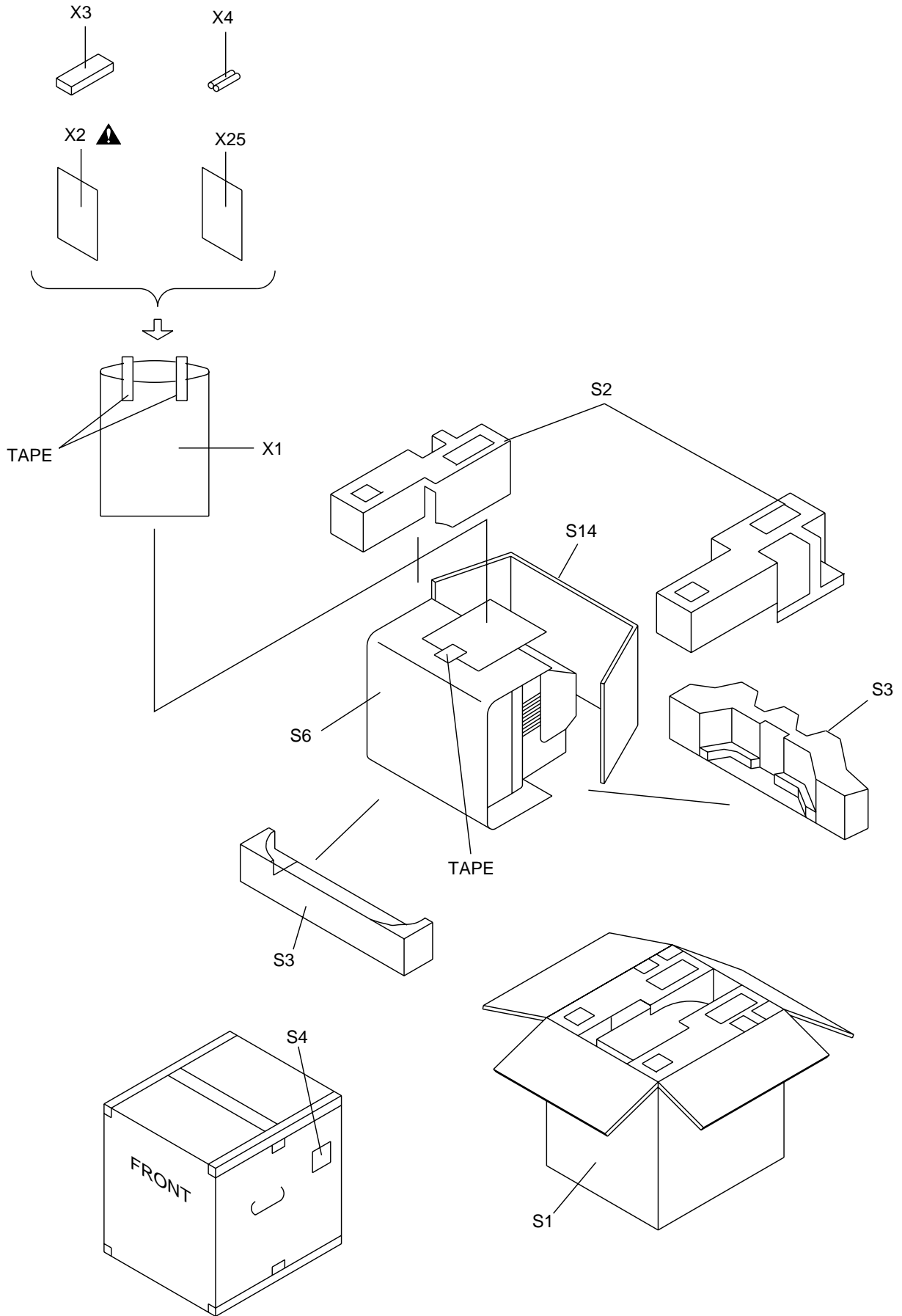
**Sec. 3: Exploded views and Parts List Section**  
● Exploded views  
● Parts List

## TABLE OF CONTENTS

Cabinet Exploded Views .....3-1-1  
Packing Exploded Views .....3-1-3  
Deck Exploded Views .....3-1-4  
Mechanical Parts List.....3-2-1  
Electrical Parts List .....3-3-1  
Deck Parts List.....3-4-1



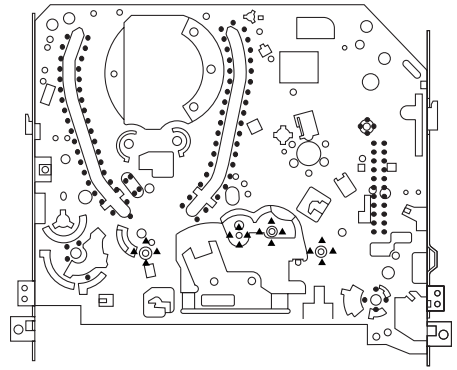
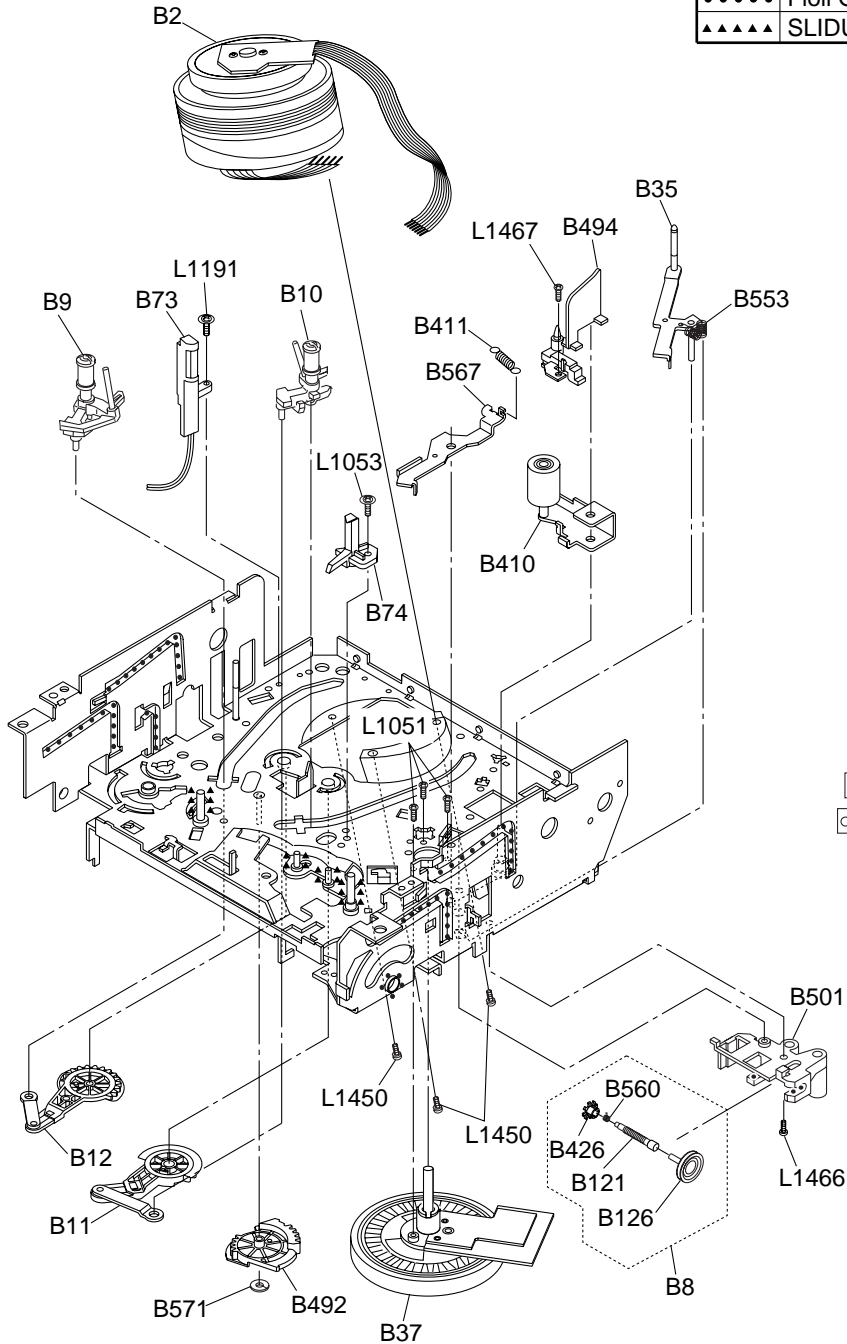
# Packing



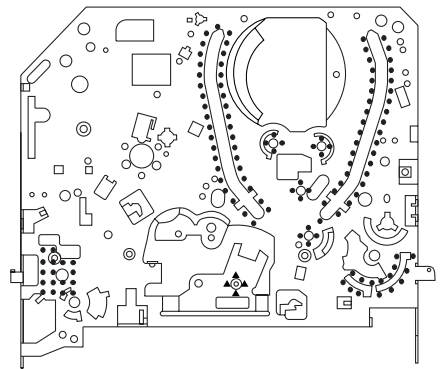
# DECK EXPLODED VIEWS

## Deck Mechanism View 1

Mark	Description
●●●●	Floil G-684G or Multemp MH-D (Blue grease)
▲▲▲▲	SLIDUS OIL #150



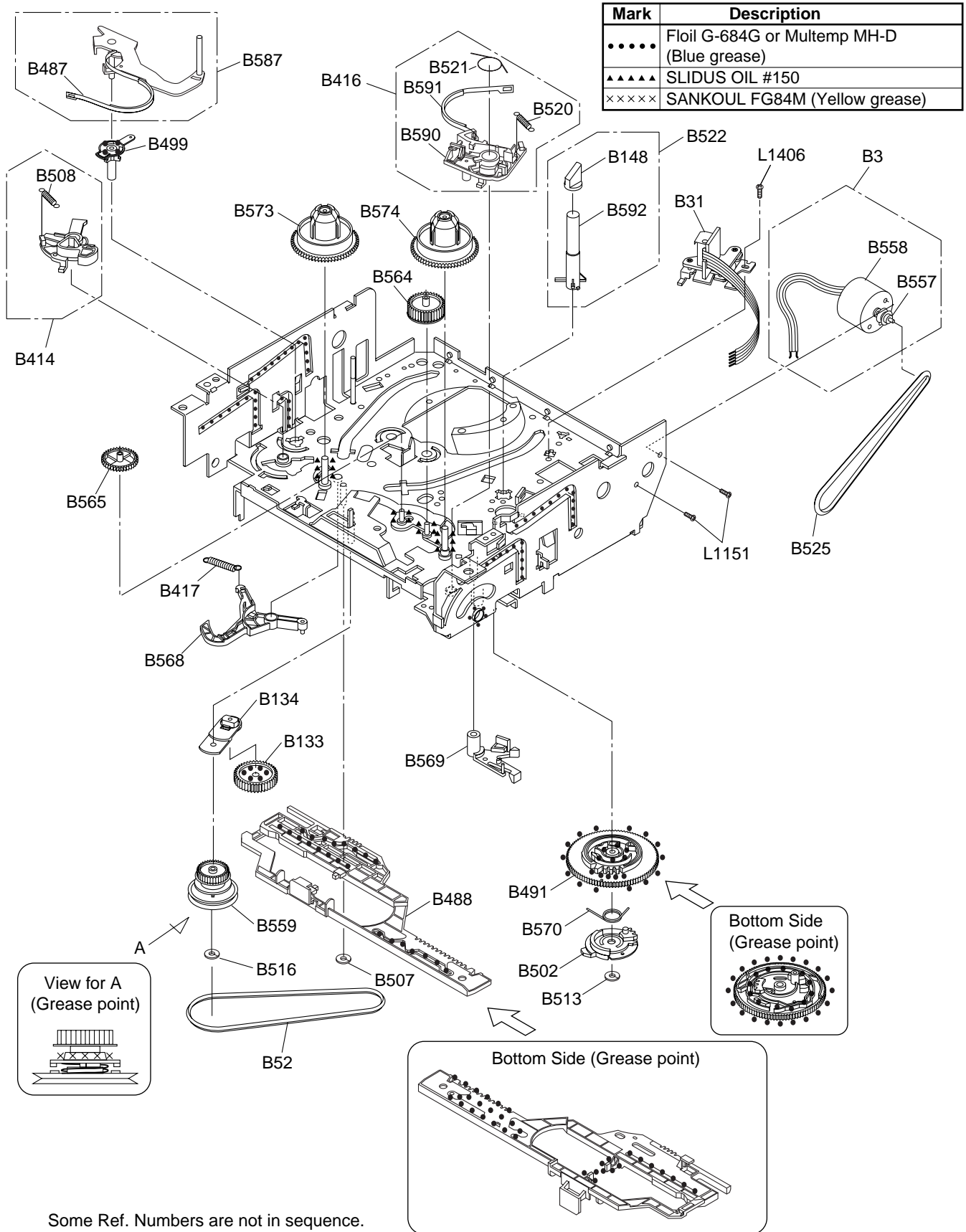
Chassis Assembly  
Top View (Lubricating Point)



Chassis Assembly  
Bottom View (Lubricating Point)

Some Ref. Numbers are not in sequence.

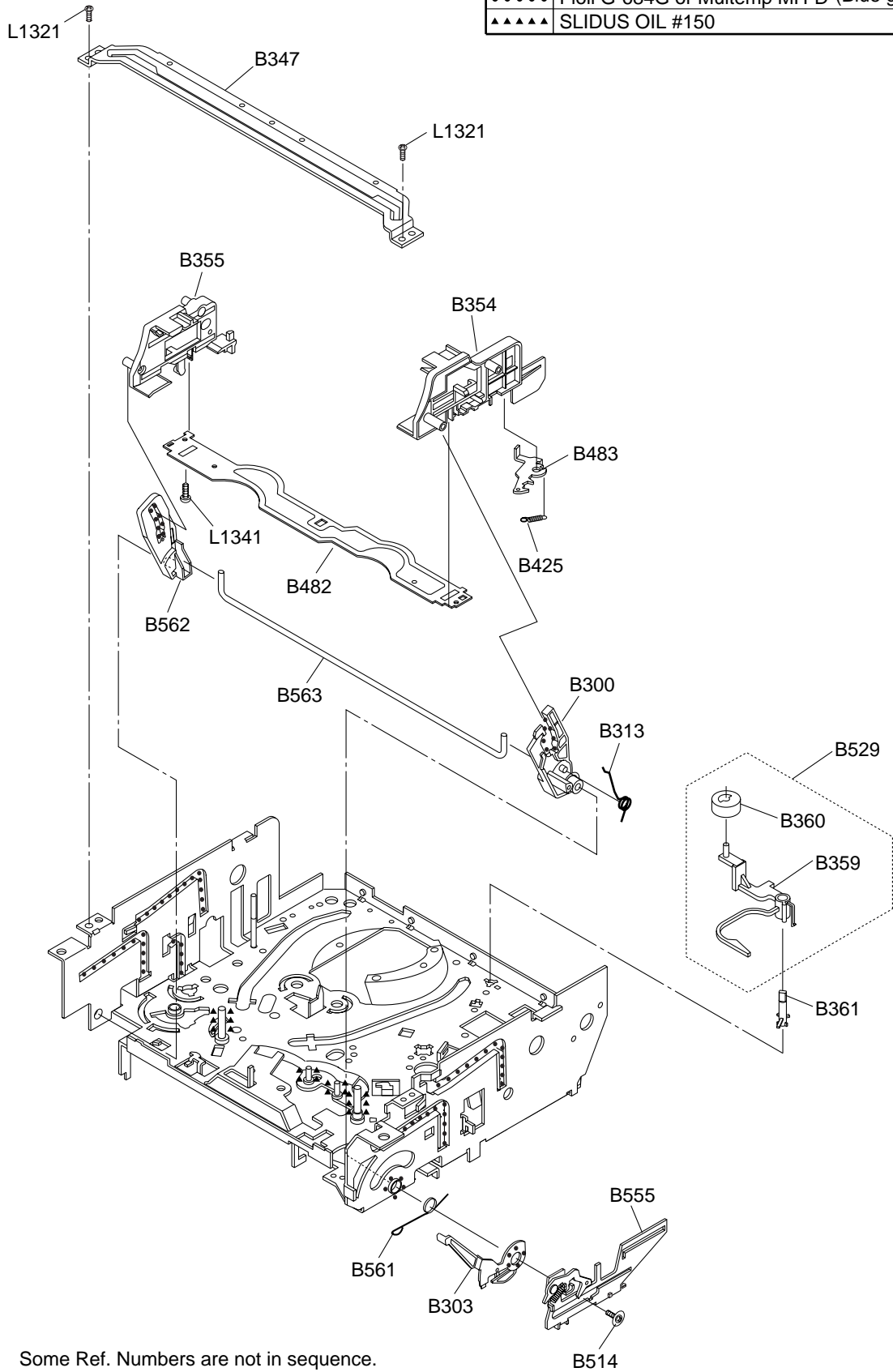
# Deck Mechanism View 2



Some Ref. Numbers are not in sequence.


# Deck Mechanism View 3

Mark	Description
•••••	Floil G-684G or Multemp MH-D (Blue grease)
▲▲▲▲▲	SLIDUS OIL #150



























# MECHANICAL PARTS LIST

**PRODUCT SAFETY NOTE:** Products marked with a  have special characteristics important to safety. Before replacing any of these components, read carefully the product safety notice in this service manual. Don't degrade the safety of the product through improper servicing.

**NOTE:**  
Parts that are not assigned part numbers (-----) are not available.

Ref. No.	Description	Part No.
A1X	FRONT CABINET ASSEMBLY T7302UC	0EM101166
A1-1	FRONT CABINET T7302UC	0EM000618
A1-2	CONTROL PLATE T7302UC	0EM201567
A1-3	BRAND PLATE T5302UC:SYLVANIA	0EM406914
A1-4	CASSETTE DOOR T5303UD	0EM406915
A1-5	DOOR SPRING B5000UA or DOOR SPRING(Z10) T5200UA	0VM403773 0EM406687
A1-6	CLOTH(4X7XT0.7) T5000UA	0EM404974
A2	REAR CABINET T7400UA	0EM000692
A3 	RATING LABEL T7404CE	-----
A4	POP LABEL T5401UB	-----
1B1	DECK ASSEMBLY CZD012/VM1626	N1626FT
B1	TENSION SPRING B0080B0:EM40808	26VH006
B2	CRT MOUNTING SCREW B0030U1:K42419 or M5 CRT SCREW TD805UF	8A00083 0EM408333
B3	SHIELD PLATE (Z11 13V) T5300UA	0EM406843
B4 	DEGAUSS HOLDER L9800UA	0EM404845
B5	CLOTH 190X15XT0.5	TS7623
B11	CLOTH(10X30XT0.5) B5900UA	0EM404486
B13	CLOTH(15X10XT0.5) L9700UA	0EM405038
CL802	WIRE ASSEMBLY 2P/150	WX1B5900-001
CLN551 	CRT GNDWIRE WX1T7400-006	WX1T7400-006
DG601 	DEGAUSSING COIL F-020 or  DEGAUSSING COIL AVDG077	LLBH00ZTM020 LLBH00ZWR015
L1	SCREW, P-TIGHT 4X18 BIND HEAD +	GBMP4180
L2	SCREW TAPPING M4X14	DBU14140
L4	SCREW, ASSEMBLED 12:M3X12	0EM406746
L7	SCREW, P-TIGHT 3X10 BIND HEAD+	GBKP3100
SP801	SPEAKER S08F02B or SPEAKER J-F097-C5	DSD0808XQ010 DSD0808DCP01
TB1	TRAY CHASSIS T5400UA	0EM000688
TB2	TOP SHIELD T5400UA	0EM201663
TB10	RCA HOLDER T5400UA	0EM407677
TB22 	19V CHASSIS NO. LABEL TJ T7400UA	-----
TB24	WIRE HOLDER T5400UA	0EM407678
TL1	SCREW, P-TIGHT 3X12 WASHER HEAD+	GCMP3120
TL3	SCREW, S-TIGHT 3X4 BIND HEAD+	GBMS3040
TL14	SCREW, B-TIGHT M3X8 BIND HEAD+	GBMB3080
TL18	SCREW, P-TIGHT M3X8 BIND HEAD+	GBCP3080
<b>PACKING</b>		
S1	CARTON T7404CE	0EM407777
S2	STYROFOAM TOP ASSEMBLY T7400UA	0EM407699
S3	STYROFOAM BOTTOM ASSEMBLY T7400UA	0EM407700
S4	SERIAL NO. LABEL T7404CE	-----
S6	SET SHEET B7500UA:1000X1700	0EM402178

Ref. No.	Description	Part No.
S14	TVCR HOLD PAD T7300UA	0EM406849
<b>ACCESSORIES</b>		
X1	POLYETHYLENE BAG 235X365XT0.03	0EM408420
X2 	OWNERS MANUAL T5404CE	0EMN02101
X3	REMOTE CONTROL 512/ERC001/N0150UD or REMOTE CONTROL 512/ERC001/N0107UD	N0150UD N0107UD
X4	DRY BATTERY R6P UM3 or DRY BATTERY R6P(AR)2PX or DRY BATTERY R6P(AR)2P X ICI or DRY BATTERY(SUNRISE) R6SSE/2S or DRY BATTERY R6P/2S	XB0M451GH001 XB0M451HU002 XB0M451HU003 XB0M451MS002 XB0M451T0001
X25	QUICK SETUP GUIDE T4104CE	0EMN01725
<b>Note:</b> 1. V501 (CRT) HAS COUPLE OF SUBSTITUTIONAL PARTS AND EACH PARTS ALSO HAS MATCHING COMBINATION WITH L551. PLEASE SEE TABLE 1 FOR DETAILS OF MATCHING COMBINATION. 2. L551 (DEFLECTION YOKE) HAS MATCHING COMBINATION WITH V501. PLEASE SEE TABLE 1 FOR DETAILS OF MATCHING COMBINATION.		
<b>CRT TYPE A</b>		
V501 	CRT A48AKH13X01 K	TCRT190CP043
<b>CRT TYPE B</b>		
L551 	DEFLECTION YOKE KDY3MDD74X	LLBY00ZMS024
V501 	CRT A48AKH13X	TCRT190CP044
V501-1	C.PMAGNET JH225-014 or CPM E-225-F01	XM04000BV009 XM04000ETC01
V501-2	WEDGE FT-00110W	XV10000T4001
V501-3	RUBBER MAGNET 20X10X1.2	XM05000BV001
<b>CRT TYPE C</b>		
L551 	DEFLECTION YOKE LLBY00ZSY008 or  DEFLECTION YOKE KDY3MDD18X	LLBY00ZSY008 LLBY00ZMS019
V501 	CRT A48LVL095X	TCRT190MS011
V501-1	C.PMAGNET JH225-014 or CPM E-225-F01	XM04000BV009 XM04000ETC01
V501-2	WEDGE FT-00110W	XV10000T4001
V501-3	RUBBER MAGNET 20X10X1.2	XM05000BV001
<b>CRT TYPE D</b>		
L551 	DEFLECTION YOKE LLBY00ZSY006 or  DEFLECTION YOKE CDY-M2019F	LLBY00ZSY006 LLBY00ZQS004
V501 	CRT A48JLL90X	TCRT190QS009
V501-1	C.PMAGNET JH225-014 or CPM E-225-F01	XM04000BV009 XM04000ETC01
V501-2	WEDGE FT-00110W	XV10000T4001
V501-3	RUBBER MAGNET 20X10X1.2	XM05000BV001
<b>CRT TYPE E</b>		
L551 	DEFLECTION YOKE LLBY00ZSY007 or  DEFLECTION YOKE CDY-M2023F or  DEFLECTION YOKE DSE-1922FU(T)	LLBY00ZSY007 LLBY00ZQS005 LLBY00ZSM007
V501 	CRT A48LRH93X(W)	TCRT190P7002
V501-1	C.PMAGNET JH225-014 or CPM E-225-F01	XM04000BV009 XM04000ETC01
V501-2	WEDGE FT-00110W	XV10000T4001
V501-3	RUBBER MAGNET 20X10X1.2	XM05000BV001
<b>CRT TYPE F</b>		
L551 	DEFLECTION YOKE 330P510A37	LLBY00ZTHA01
V501 	CRT A48LGS30X	TCRT190THA01
V501-1	C.PMAGNET JH225-014 or CPM E-225-F01	XM04000BV009 XM04000ETC01
V501-2	WEDGE FT-00110W	XV10000T4001

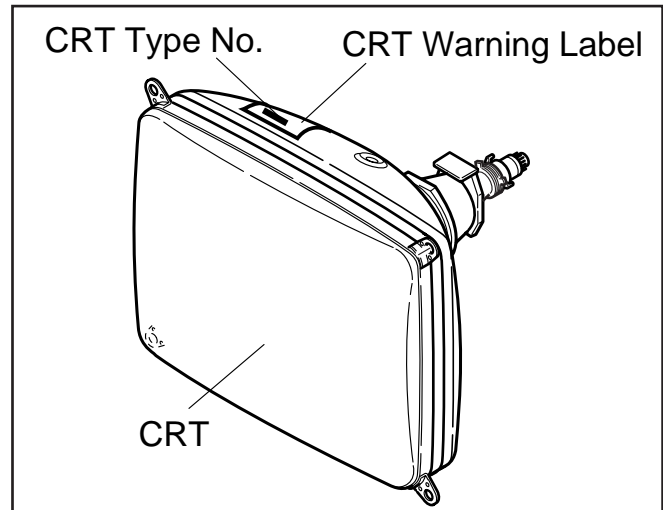
Ref. No.	Description	Part No.
V501-3	RUBBER MAGNET 20X10X1.2	XM05000BV001
<b>CRT TYPE G</b>		
L551▲	DEFLECTION YOKE LLBY00ZSY007 or	LLBY00ZSY007
▲	DEFLECTION YOKE CDY-M2023F or	LLBY00ZQS005
▲	DEFLECTION YOKE DSE-1922FU(T)	LLBY00ZSM007
V501▲	CRT A48LRH93X(W)D	TCRT190PTD01
V501-1	C.PMAGNET JH225-014 or	XM04000BV009
	GPM E-225-F01	XM04000ETC01
V501-2	WEDGE FT-00110W	XV10000T4001
V501-3	RUBBER MAGNET 20X10X1.2	XM05000BV001

**Table 1 (V501 and L551 Combination)**

**Note 1:** Purity and Convergence Adjustments must be performed following CRT replacement. Refer to Electrical Adjustment Instructions.


**Note 2:** Please confirm CRT Type No. on the CRT Warning Label which is located on the CRT. Then See the Table 1 for V501 and L551 combination chart. Please refer this CRT, Deflection Yoke combination chart for parts order.

### CRT Warning Label Location



V501: CRT Type No.	V501: CRT Part No.	L551: Deflection Yoke Part No.
A48AKH13X01 K	TCRT190CP043	-----
A48AKH13X	TCRT190CP044	LLBY00ZMS024
A48LVL095X	TCRT190MS011	LLBY00ZSY008
		LLBY00ZMS019
A48JLL90X	TCRT190QS009	LLBY00ZSY006
		LLBY00ZQS004
A48LRH93X(W)	TCRT190P7002	LLBY00ZSY007
		LLBY00ZQS005
		LLBY00ZSM007
A48LGS30X	TCRT190THA01	LLBY00ZTHA01
A48LRH93X(W)D	TCRT190PTD01	LLBY00ZSY007
		LLBY00ZQS005
		LLBY00ZSM007

# ELECTRICAL PARTS LIST

**PRODUCT SAFETY NOTE:** Products marked with a  have special characteristics important to safety. Before replacing any of these components, read carefully the product safety notice in this service manual. Don't degrade the safety of the product through improper servicing.

## NOTES:

- Parts that are not assigned part numbers (-----) are not available.
- Tolerance of Capacitors and Resistors are noted with the following symbols.

C.....±0.25%    D.....±0.5%    F.....±1%  
 G.....±2%    J.....±5%    K.....±10%  
 M.....±20%    N.....±30%    Z.....+80/-20%

## MMA CBA

Ref. No.	Description	Part No.
	MMA CBA Consists of the following	0ESA05343
	MAIN CBA CRT CBA SENSOR CBA	----- ----- 0ESA04524

## MAIN CBA

Ref. No.	Description	Part No.
	MAIN CBA Consists of the following	-----
<b>CAPACITORS</b>		
C005	ELECTROLYTIC CAP. 220µF/16V M or	CE1CMASDL221
	ELECTROLYTIC CAP. 220µF/16V M	CE1CMASTL221
C007	CHIP CERAMIC CAP. B K 0.01µF/50V	CHD1JKB0B103
C008	ELECTROLYTIC CAP. 10µF/50V M or	CE1JMASDL100
	ELECTROLYTIC CAP. 10µF/50V M	CE1JMASTL100
C032	CHIP CERAMIC CAP.(MELF) F Z 0.01µF/16V	CZM1CZB0F103
C033	CERAMIC CAP.(AX) F Z 0.01µF/25V	CCA1EZTFZ103
C035	CERAMIC CAP.(AX) CH J 15pF/50V	CCA1JTCH150
C036	CHIP CERAMIC CAP. B K 220pF/50V	CHD1JKB0B221
C037	CHIP CERAMIC CAP. F Z 1µF/10V	CHD1AZB0F105
C039	ELECTROLYTIC CAP. 1µF/50V M H7	CE1JMAVSL1R0
C040	CHIP CERAMIC CAP. B K 0.01µF/50V	CHD1JKB0B103
C042	CHIP CERAMIC CAP. F Z 1µF/10V	CHD1AZB0F105
C043	CHIP CERAMIC CAP. F Z 0.022µF/50V	CHD1JZB0F223
C044	CHIP CERAMIC CAP.(MELF) F Z 0.01µF/16V	CZM1CZB0F103
C046	CERAMIC CAP.(AX) F Z 0.01µF/25V	CCA1EZTFZ103
C047	CHIP CERAMIC CAP. B K 0.01µF/50V	CHD1JKB0B103
C048	ELECTROLYTIC CAP. 47µF/50V M or	CE1JMASDL470
	ELECTROLYTIC CAP. 47µF/50V M	CE1JMASTL470
C049	CHIP CERAMIC CAP. F Z 1µF/10V	CHD1AZB0F105
C052	CHIP CERAMIC CAP. B K 0.047µF/50V	CHD1JKB0B473
C053	CHIP CERAMIC CAP. B K 0.047µF/50V	CHD1JKB0B473
C054	CERAMIC CAP.(AX) Y M 0.01µF/16V	CCA1CMT0Y103
C203	CHIP CERAMIC CAP. F Z 1µF/10V	CHD1AZB0F105
C207	ELECTROLYTIC CAP. 47µF/6.3V M H7	CE0KMAVSL470
C208	ELECTROLYTIC CAP. 47µF/6.3V M H7	CE0KMAVSL470

Ref. No.	Description	Part No.
C210	CHIP CERAMIC CAP. F Z 1µF/10V	CHD1AZB0F105
C211	CERAMIC CAP.(AX) F Z 0.01µF/25V	CCA1EZTFZ103
C212	CHIP CERAMIC CAP.(MELF) SL J 22pF/50V	CZM1JJB0B220
C213	CHIP CERAMIC CAP.(MELF) SL J 22pF/50V	CZM1JJB0B220
C214	ELECTROLYTIC CAP.(SS.T) 220µF/10V M H7	CA1A221S6028
C216	CERAMIC CAP.(AX) Y M 0.01µF/16V	CCA1CMT0Y103
C217	CHIP CERAMIC CAP.(MELF) SL D 10pF/50V	CZM1JDBSL100
C218	CHIP CERAMIC CAP.(MELF) SL J 15pF/50V	CZM1JJB0B150
C219	CHIP CERAMIC CAP. B K 0.01µF/50V	CHD1JKB0B103
C220	ELECTROLYTIC CAP.(SS.T) 220µF/10V M H7	CA1A221S6028
C221	CHIP CERAMIC CAP.(MELF) F Z 0.01µF/16V	CZM1CZB0F103
C222	CHIP CERAMIC CAP.(MELF) Y K 2200pF/35V	CZM1GKBOY222
C223	CHIP CERAMIC CAP. F Z 1µF/10V	CHD1AZB0F105
C224	CHIP CERAMIC CAP.(MELF) Y K 1000pF/35V	CZM1GKBOY102
C225	CHIP CERAMIC CAP.(MELF) W K 560pF/50V	CZM1JKB0B561
C231	CHIP CERAMIC CAP. CH J 100pF/50V	CHD1JJBCH101
C232	CHIP CERAMIC CAP. CH J 100pF/50V	CHD1JJBCH101
C233	CHIP CERAMIC CAP. B K 0.01µF/50V	CHD1JKB0B103
C235	CERAMIC CAP.(AX) X K 4700pF/16V	CCA1CKT0X472
C236	CERAMIC CAP.(AX) F Z 0.047µF/16V	CCA1CZTFZ473
C238	CHIP CERAMIC CAP.(MELF) Y K 1000pF/35V	CZM1GKBOY102
C239	ELECTROLYTIC CAP. 22µF/50V M or	CE1JMASDL220
	ELECTROLYTIC CAP. 22µF/50V M	CE1JMASTL220
C240	CERAMIC CAP.(AX) B J 560pF/50V	CCA1JBT0B561
C241	CHIP CERAMIC CAP. B K 4700pF/50V	CHD1JKB0B472
C243	ELECTROLYTIC CAP. 22µF/16V M LL or	CE1CMASLL220
	ELECTROLYTIC CAP. 22µF/16V M LL	CE1CMASLH220
C245	ELECTROLYTIC CAP. 220µF/16V M or	CE1CMASDL221
	ELECTROLYTIC CAP. 220µF/16V M	CE1CMASTL221
C247	ELECTROLYTIC CAP. 220µF/16V M or	CE1CMASDL221
	ELECTROLYTIC CAP. 220µF/16V M	CE1CMASTL221
C251	CERAMIC CAP.(AX) B K 1000pF/50V	CCA1JKT0B102
C252	ELECTROLYTIC CAP.(SS.T) 100µF/16V M H7	CA1C101S6028
C253	ELECTROLYTIC CAP. 100µF/6.3V M or	CE0KMASDL101
	ELECTROLYTIC CAP. 100µF/6.3V M	CE0KMASTL101
C254	ELECTROLYTIC CAP. 47µF/35V M or	CE1GMASDL470
	ELECTROLYTIC CAP. 47µF/35V M	CE1GMASTL470
C257	CHIP CERAMIC CAP.(MELF) Y K 1000pF/35V	CZM1GKBOY102
C301	CHIP CERAMIC CAP.(MELF) F Z 0.01µF/16V	CZM1CZB0F103
C302	CHIP CERAMIC CAP. CH J 33pF/50V	CHD1JJBCH330
C303	CHIP CERAMIC CAP. CH J 33pF/50V	CHD1JJBCH330
C304	CHIP CERAMIC CAP. CH J 33pF/50V	CHD1JJBCH330
C309	CHIP CERAMIC CAP. F Z 1µF/10V	CHD1AZB0F105
C310	CHIP CERAMIC CAP. F Z 1µF/10V	CHD1AZB0F105
C314	CHIP CERAMIC CAP. B K 0.01µF/50V	CHD1JKB0B103
C315	CHIP CERAMIC CAP. F Z 1µF/10V	CHD1AZB0F105
C316	CHIP CERAMIC CAP. F Z 2.2µF/10V or	CHD1AZB0F225
	CHIP CERAMIC CAP. F Z 2.2µF/6.3V	CHD1KZB0F225
C317	CHIP CERAMIC CAP.(MELF) F Z 0.01µF/16V	CZM1CZB0F103
C319	CHIP CERAMIC CAP. F Z 1µF/10V	CHD1AZB0F105
C320	CHIP CERAMIC CAP. F Z 1µF/10V	CHD1AZB0F105
C321	ELECTROLYTIC CAP.(SS.T) 220µF/10V M H7	CA1A221S6028
C322	CHIP CERAMIC CAP.(MELF) F Z 0.01µF/16V	CZM1CZB0F103
C323	CHIP CERAMIC CAP. F Z 2.2µF/10V or	CHD1AZB0F225
	CHIP CERAMIC CAP. F Z 2.2µF/6.3V	CHD1KZB0F225
C324	CHIP CERAMIC CAP. F Z 1µF/10V	CHD1AZB0F105
C325	CHIP CERAMIC CAP. F Z 1µF/10V	CHD1AZB0F105

Ref. No.	Description	Part No.
C326	CHIP CERAMIC CAP. F Z 1µF/10V	CHD1AZB0F105
C327	ELECTROLYTIC CAP. 100µF/10V M H7	CE1AMAVSL101
C330	CHIP CERAMIC CAP.(MELF) F Z 0.01µF/16V	CZM1CZB0F103
C331	ELECTROLYTIC CAP.(SS.T) 220µF/10V M H7	CA1A221S6028
C336	ELECTROLYTIC CAP. 1µF/50V H7(P=2.5MM)	CA1J1R0S6023
C337	CHIP CERAMIC CAP. B K 0.01µF/50V	CHD1JKB0B103
C338	CHIP CERAMIC CAP. F Z 2.2µF/10V or CHIP CERAMIC CAP. F Z 2.2µF/6.3V	CHD1AZB0F225 CHD1KZB0F225
C339	CHIP CERAMIC CAP. B K 0.01µF/50V	CHD1JKB0B103
C340	CHIP CERAMIC CAP. CH J 47pF/50V	CHD1JJBCH470
C342	ELECTROLYTIC CAP.(SS.T) 220µF/10V M H7	CA1A221S6028
C351	ELECTROLYTIC CAP.(SS.T) 220µF/10V M H7	CA1A221S6028
C352	ELECTROLYTIC CAP.(SS.T) 220µF/10V M H7	CA1A221S6028
C410	ELECTROLYTIC CAP. 1µF/50V M H7	CE1JMAVSL1R0
C411	ELECTROLYTIC CAP. 100µF/10V M H7	CE1AMAVSL101
C412	CHIP CERAMIC CAP.(MELF) F Z 0.01µF/16V	CZM1CZB0F103
C413	CHIP CERAMIC CAP.(MELF) W K 390pF/50V	CZM1JKB0B391
C414	CHIP CERAMIC CAP. F Z 1µF/10V	CHD1AZB0F105
C416	CHIP CERAMIC CAP.(MELF) B K 180pF/50V	CZM1JKB0B181
C417	CHIP CERAMIC CAP.(MELF) SL J 22pF/50V	CZM1JJBLS220
C418	PCB JUMPER D0.6-P5.0	JW5.0T
C420	ELECTROLYTIC CAP. 22µF/16V M H7	CE1CMAVSL220
C421	ELECTROLYTIC CAP. 4.7µF/50V M H7	CE1JMAVSL4R7
C423	ELECTROLYTIC CAP. 4.7µF/50V M H7	CE1JMAVSL4R7
C424	CHIP CERAMIC CAP. F Z 1µF/10V	CHD1AZB0F105
C425	CHIP CERAMIC CAP. F Z 1µF/10V	CHD1AZB0F105
C426	ELECTROLYTIC CAP. 22µF/16V M H7	CE1CMAVSL220
C427	CERAMIC CAP.(AX) B K 0.01µF/50V	CA1J103TU011
C428	CHIP CERAMIC CAP.(MELF) F Z 0.01µF/16V	CZM1CZB0F103
C429	ELECTROLYTIC CAP. 47µF/6.3V M H7	CE0KMAVSL470
C430	CHIP CERAMIC CAP. F Z 0.022µF/50V	CHD1JZB0F223
C431	CHIP CERAMIC CAP. F Z 1µF/10V	CHD1AZB0F105
C434	CHIP CERAMIC CAP. F Z 1µF/10V	CHD1AZB0F105
C435	ELECTROLYTIC CAP. 2.2µF/50V M H7	CE1JMAVSL2R2
C436	CHIP CERAMIC CAP. B K 3900pF/50V	CHD1JKB0B392
C438	CHIP CERAMIC CAP. F Z 1µF/10V	CHD1AZB0F105
C439	CHIP CERAMIC CAP. B K 0.01µF/50V	CHD1JKB0B103
C440	CHIP CERAMIC CAP. F Z 1µF/10V	CHD1AZB0F105
C441	CHIP CERAMIC CAP. F Z 1µF/10V	CHD1AZB0F105
C442	CHIP CERAMIC CAP. B K 0.047µF/50V	CHD1JKB0B473
C443	CHIP CERAMIC CAP. B K 0.047µF/50V	CHD1JKB0B473
C444	ELECTROLYTIC CAP. 22µF/16V M H7	CE1CMAVSL220
C445	CHIP CERAMIC CAP. B K 0.01µF/50V	CHD1JKB0B103
C446	CHIP CERAMIC CAP. F Z 1µF/10V	CHD1AZB0F105
C447	CHIP CERAMIC CAP. B K 0.01µF/50V	CHD1JKB0B103
C448	CERAMIC CAP.(AX) B K 0.01µF/50V	CA1J103TU011
C449	CHIP CERAMIC CAP. B K 0.01µF/50V	CHD1JKB0B103
C450	CHIP CERAMIC CAP. CH J 100pF/50V	CHD1JJBCH101
C552	MYLAR CAP. 0.22µF/50V J or FILM CAP.(P) 0.22µF/50V J	CMA1JJS00224 CA1J224MS029
C553	ELECTROLYTIC CAP. 2.2µF/50V M LL or ELECTROLYTIC CAP. 2.2µF/50V LL	CE1JMASLL2R2 CE1JMASLH2R2
C555	ELECTROLYTIC CAP. 47µF/35V M or ELECTROLYTIC CAP. 47µF/35V M	CE1GMASDL470 CE1GMASDL470
C556	ELECTROLYTIC CAP. 1000µF/25V M or ELECTROLYTIC CAP. 1000µF/25V M	CE1EMZPDL102 CE1EMZPDL102
C558	CERAMIC CAP.(AX) B K 0.01µF/50V	CA1J103TU011
C559	ELECTROLYTIC CAP. 330µF/35V M or ELECTROLYTIC CAP. 330µF/35V M	CE1GMZPDL331 CE1GMZPDL331
C560	FILM CAP.(P) 0.01µF/50V J or FILM CAP.(P) 0.01µF/50V J	CMA1JJS00103 CA1J103MS029

Ref. No.	Description	Part No.
C572	P.P.CAP 0.47µF/200 J or PP CAP. 0.47µF/250V J	CA2D474VC012 CT2E474MS041
C574▲	ELECTROLYTIC CAP. 4.7µF/250V M or ▲ ELECTROLYTIC CAP. 4.7µF/250V M	CE2EMASDL4R7 CE2EMASTL4R7
C577	FILM CAP.(P) 0.022µF/50V J or FILM CAP.(P) 0.022µF/50V J	CMA1JJS00223 CA1J223MS029
C578	ELECTROLYTIC CAP. 47µF/35V M or ELECTROLYTIC CAP. 47µF/35V M	CE1GMASDL470 CE1GMASDL470
C580▲	P.P.CAP 0.01µF/1.6KV J or ▲ PP CAP. 0.01µF/1.6KV J or ▲ METALLIZED FILM CAP. 0.01µF/1.6KV J or ▲ POLYPROPYLENE FILM CAP. 0.01µF/1.6KV	CA3C103VC011 CT3C103MS039 CT3C103F7004 CT3C103HJE16
C581▲	▲ CERAMIC CAP. BN 1500pF/2KV or ▲ CERAMIC CAP. 1500pF/2KV	CCD3DKA0B152 CA3D152PAN04
C584▲	▲ ELECTROLYTIC CAP. 1µF/160V M or ▲ ELECTROLYTIC CAP. 1µF/160V M	CE2CMASDL1R0 CE2CMASDL010
C591	ELECTROLYTIC CAP. 1µF/50V M H7	CE1JMAVSL1R0
C592	ELECTROLYTIC CAP. 4.7µF/50V M H7	CE1JMAVSL4R7
C593	ELECTROLYTIC CAP. 2.2µF/50V M or ELECTROLYTIC CAP. 2.2µF/50V M	CE1JMASDL2R2 CE1JMASDL2R2
C594	ELECTROLYTIC CAP. 47µF/160V M W/F or ELECTROLYTIC CAP. 47µF/160V M W/F	CE2CMZNDL470 CE2CMZNL470
C602▲	▲ SAFETY CAP. 4700pF/250V KX	CA2E472MR050
C605▲	▲ METALLIZED FILM CAP. 0.1µF/250V or ▲ FILM CAP.(MP) 0.1µF/250V K or ▲ METALLIZED FILM CAP. 0.1µF/275V K	CT2E104MS037 CT2E104DC011 CT2E104HJE06
C606	CERAMIC CAP. F Z 0.01µF/500V or CERAMIC CAP. 0.01µF/AC250V	CCD2JZP0F103 CCD2EZA0F103
C607	CERAMIC CAP. F Z 0.01µF/500V or CERAMIC CAP. 0.01µF/AC250V	CCD2JZP0F103 CCD2EZA0F103
C610	ELECTROLYTIC CAP. 220µF/200V SL X or ELECTROLYTIC CAP. 220µF/200V	CA2D221S6003 CA2D221NC088
C611	CERAMIC CAP. BN 680pF/2KV or CERAMIC CAP. 680pF/2KV	CCD3DKA0B681 CA3D681PAN04
C612	FILM CAP.(P) 0.033µF/50V J or FILM CAP.(P) 0.033µF/50V J	CMA1JJS00333 CA1J333MS029
C613	FILM CAP.(P) 0.0012µF/50V J or FILM CAP.(P) 0.0012µF/50V J	CMA1JJS00122 CA1J122MS029
C614	FILM CAP.(P) 0.082µF/50V J or FILM CAP.(P) 0.082µF/50V J	CMA1JJS00823 CA1J823MS029
C615	CERAMIC CAP. BN 820pF/2KV or CERAMIC CAP. 820pF/2KV	CCD3DKA0B821 CA3D821PAN04
C616▲	▲ ELECTROLYTIC CAP. 100µF/160V M or ▲ ELECTROLYTIC CAP. 100µF/160V M or ▲ ELECTROLYTIC CAP. 100µF/160V M W/F	CE2CMZPDL101 CE2CMZPDL101 CE2CMZPDL101
C617▲	▲ ELECTROLYTIC CAP. 470µF/35V M or ▲ ELECTROLYTIC CAP. 470µF/35V M	CE1GMZPDL471 CE1GMZPDL471
C618▲	▲ ELECTROLYTIC CAP. 1000µF/16V M or ▲ ELECTROLYTIC CAP. 1000µF/16V M	CE1CMZPDL102 CE1CMZPDL102
C619	ELECTROLYTIC CAP. 470µF/16V M or ELECTROLYTIC CAP. 470µF/16V M	CE1CMASDL471 CE1CMASDL471
C620▲	▲ ELECTROLYTIC CAP. 1000µF/16V M or ▲ ELECTROLYTIC CAP. 1000µF/16V M	CE1CMZPDL102 CE1CMZPDL102
C622	CERAMIC CAP.(AX) B K 220pF/50V	CCA1JKT0B221
C624	CHIP CERAMIC CAP. B K 0.01µF/50V	CHD1JKB0B103
C625	ELECTROLYTIC CAP. 1µF/50V M or ELECTROLYTIC CAP. 1µF/50V M or ELECTROLYTIC CAP. 1µF/50V M	CE1JMASDL1R0 CE1JMASDL010 CE1JMASTL1R0
C626	ELECTROLYTIC CAP. 4.7µF/50V M H7	CE1JMAVSL4R7
C628	ELECTROLYTIC CAP. 10µF/50V M or ELECTROLYTIC CAP. 10µF/50V M	CE1JMASDL100 CE1JMASTL100

Ref. No.	Description	Part No.
C629	ELECTROLYTIC CAP. 47μF/35V M or	CE1GMASDL470
	ELECTROLYTIC CAP. 47μF/35V M	CE1GMASDL470
C630	ELECTROLYTIC CAP. 100μF/10V M or	CE1AMASDL101
	ELECTROLYTIC CAP. 100μF/10V M	CE1AMASDL101
C631	ELECTROLYTIC CAP. 220μF/6.3V M or	CE0KMASDL221
	ELECTROLYTIC CAP. 220μF/6.3V M	CE0KMASDL221
C632	ELECTROLYTIC CAP.(SS.T) 100μF/16V M H7	CA1C101S6028
C633	ELECTROLYTIC CAP.(SS.T) 47μF/25V M H7	CA1E470S6028
C634	ELECTROLYTIC CAP.(SS.T) 100μF/16V M H7	CA1C101S6028
C635	ELECTROLYTIC CAP. 47μF/35V M or	CE1GMASDL470
	ELECTROLYTIC CAP. 47μF/35V M	CE1GMASDL470
C636	CHIP CERAMIC CAP. F Z 0.1μF/50V	CHD1JZB0F104
C639	CERAMIC CAP. B K 220pF/500V	CCD2JKS0B221
C641	CHIP CERAMIC CAP. CH J 100pF/50V	CHD1JJBCH101
C648	ELECTROLYTIC CAP. 22μF/16V M H7	CE1CMAVSL220
C801	ELECTROLYTIC CAP. 220μF/16V M H7	CE1CMASSL221
C802	ELECTROLYTIC CAP. 470μF/16V M or	CE1CMAASDL471
	ELECTROLYTIC CAP. 470μF/16V M	CE1CMAASDL471
C803	ELECTROLYTIC CAP. 10μF/50V M H7	CE1JMAVSL100
C804	ELECTROLYTIC CAP. 0.22μF/50V M H7	CE1JMAVSLR22
C805	CHIP CERAMIC CAP. B K 4700pF/50V	CHD1JKB0B472
C853	CERAMIC CAP.(AX) F Z 0.1μF/50V	CCA1JZTFZ104
C854	ELECTROLYTIC CAP. 22μF/16V M H7	CE1CMAVSL220
C856	CHIP CERAMIC CAP. F Z 0.1μF/50V	CHD1JZB0F104
C857	ELECTROLYTIC CAP. 33μF/6.3V M H7	CE0KMAVSL330
C858	ELECTROLYTIC CAP. 4.7μF/50V M H7	CE1JMAVSL4R7
C859	CERAMIC CAP.(AX) F Z 0.1μF/50V	CCA1JZTFZ104
C860	CHIP CERAMIC CAP.(MELF) Y K 1000pF/35V	CZM1GKB0Y102
C862	CHIP CERAMIC CAP. B K 0.01μF/50V	CHD1JKB0B103
C863	ELECTROLYTIC CAP. 4.7μF/50V M H7	CE1JMAVSL4R7
C865	CHIP CERAMIC CAP. B K 1200pF/50V	CHD1JKB0B122
C866	CHIP CERAMIC CAP. B K 2700pF/50V	CHD1JKB0B272
C872	ELECTROLYTIC CAP. 47μF/6.3V M H7	CE0KMAVSL470
C873	ELECTROLYTIC CAP.(SS.T) 100μF/16V M H7	CA1C101S6028
C874	CERAMIC CAP. B K 470pF/100V or	CCD2AKS0B471
	CERAMIC CAP. B K 470pF/500V	CCD2JKS0B471
C875	FILM CAP.(P) 0.018μF/100V J or	CMA2AJS00183
	FILM CAP.(P) 0.018μF/50V J	CA1J183MS029
<b>CONNECTORS</b>		
CN571	CONNECTOR BASE, 5P TV-50P-05-V3 or	J3TVC05TG002
	CONNECTOR BASE, 5P RTB-1.5-5P	J3RTC05JG001
CN573	PIN CONNECTOR 005P-5100 or	JTEA001TG001
	CONNECTOR PIN, 1P LV or	1700576
	CONNECTOR PIN, 1P RT-01N-2.3A	1730688
CN601	CONNECTOR BASE, 2P TV-50P-02-V3 or	J3TVC02TG002
	CONNECTOR BASE, 2P RTB-1.5-2P	J3RTC02JG001
CN801	STRAIGHT CONNECTOR BASE 00 8283 0212 00 000 or	J383C02UG002
	STRAIGHT PIN HEADER, 2P 173981-2	1770258
<b>DIODES</b>		
D031	SWITCHING DIODE 1SS133(T-77) or	QDTZ001SS133
	SWITCHING DIODE 1N4148	NDTZ001N4148
D203	LED SIR-563ST3F P or	QPQPS1R563ST
	LED SIR-563ST3F Q	QPQQS1R563ST
D204	LED LTL-4214M1 or	NPQZLTL4214M
	LED(RED)L-FORMING LT1814G-81-FL or	NP4Z0LT1814G
	LED L-53HT or	NP4Z000L53HT
	LED LAMP 333HT/F45-50K or	NPWK333HTF45
	LED LAMP 333HT/F45-50L or	NPWL333HTF45
	LED LAMP 333HT/F45-50M	NPWM333HTF45
D208	ZENER DIODE MTZJT-776.2B or	QDTB0MTZJ6R2

Ref. No.	Description	Part No.
	ZENER DIODE DZ-6.2BSBT265	NDTB0DZ6R2BS
D225	ZENER DIODE MTZJT-776.2B or	QDTB0MTZJ6R2
	ZENER DIODE DZ-6.2BSBT265	NDTB0DZ6R2BS
D226	ZENER DIODE MTZJT-776.2B or	QDTB0MTZJ6R2
	ZENER DIODE DZ-6.2BSBT265	NDTB0DZ6R2BS
D227	CARBON RES. 1/4W J 1k Ω	RCX4JATZ0102
D231	ZENER DIODE MTZJT-775.6B or	QDTB0MTZJ5R6
	ZENER DIODE DZ-5.6BSBT265	NDTB0DZ5R6BS
D234	PCB JUMPER D0.6-P5.0	JW5.0T
D251	ZENER DIODE MTZJT-7715B or	QDTB00MTZJ15
	ZENER DIODE DZ-15BSBT265	NDTB00DZ15BS
D252	CARBON RES. 1/4W J 1.5k Ω	RCX4JATZ0152
D253	ZENER DIODE MTZJT-7718B or	QDTB00MTZJ18
	ZENER DIODE DZ-18BSBT265	NDTB00DZ18BS
D302	SWITCHING DIODE 1SS133(T-77) or	QDTZ001SS133
	SWITCHING DIODE 1N4148	NDTZ001N4148
D303	SWITCHING DIODE 1SS133(T-77) or	QDTZ001SS133
	SWITCHING DIODE 1N4148	NDTZ001N4148
D304	SWITCHING DIODE 1SS133(T-77) or	QDTZ001SS133
	SWITCHING DIODE 1N4148	NDTZ001N4148
D305	SWITCHING DIODE 1SS133(T-77) or	QDTZ001SS133
	SWITCHING DIODE 1N4148	NDTZ001N4148
D306	SWITCHING DIODE 1SS133(T-77) or	QDTZ001SS133
	SWITCHING DIODE 1N4148	NDTZ001N4148
D309	SWITCHING DIODE 1SS133(T-77) or	QDTZ001SS133
	SWITCHING DIODE 1N4148	NDTZ001N4148
D311	SWITCHING DIODE 1SS133(T-77) or	QDTZ001SS133
	SWITCHING DIODE 1N4148	NDTZ001N4148
D312	SWITCHING DIODE 1SS133(T-77) or	QDTZ001SS133
	SWITCHING DIODE 1N4148	NDTZ001N4148
D313	SWITCHING DIODE 1SS133(T-77) or	QDTZ001SS133
	SWITCHING DIODE 1N4148	NDTZ001N4148
D314	SWITCHING DIODE 1SS133(T-77) or	QDTZ001SS133
	SWITCHING DIODE 1N4148	NDTZ001N4148
D315	SWITCHING DIODE 1SS133(T-77) or	QDTZ001SS133
	SWITCHING DIODE 1N4148	NDTZ001N4148
D401	SWITCHING DIODE 1SS133(T-77) or	QDTZ001SS133
	SWITCHING DIODE 1N4148	NDTZ001N4148
D552	DIODE 1N5397-B or	NDLZ001N5397
	RECTIFIER DIODE ERB12-06	QDQZ0ERB1206
D571▲	DIODE FR154 or	NDLZ000FR154
▲	FAST RECOVERY DIODE ERB44-02	QDPZ0ERB4402
D572▲	DIODE FR104-B	NDLZ000FR104
D584	SWITCHING DIODE 1SS133(T-77) or	QDTZ001SS133
	SWITCHING DIODE 1N4148	NDTZ001N4148
D585	ZENER DIODE MTZJT-775.1B or	QDTB0MTZJ5R1
	ZENER DIODE DZ-5.1BSBT265	NDTB0DZ5R1BS
D591▲	ZENER DIODE MTZJT-7736B or	QDTB00MTZJ36
▲	ZENER DIODE DZ-36BSBT265	NDTB00DZ36BS
D595▲	ZENER DIODE MTZJT-7718B or	QDTB00MTZJ18
▲	ZENER DIODE DZ-18BSBT265	NDTB00DZ18BS
D596	SWITCHING DIODE 1SS133(T-77) or	QDTZ001SS133
	SWITCHING DIODE 1N4148	NDTZ001N4148
D597	SWITCHING DIODE 1SS133(T-77) or	QDTZ001SS133
	SWITCHING DIODE 1N4148	NDTZ001N4148
D598▲	DIODE FR104-B	NDLZ000FR104
D601	PCB JUMPER D0.6-P10.0	JW10.0T
D603▲	DIODE 1N5397-B or	NDLZ001N5397
▲	RECTIFIER DIODE ERB12-06	QDQZ0ERB1206
D604▲	DIODE 1N5397-B or	NDLZ001N5397
▲	RECTIFIER DIODE ERB12-06	QDQZ0ERB1206

Ref. No.	Description	Part No.
D605▲	DIODE 1N5397-B or	NDLZ001N5397
▲	RECTIFIER DIODE ERB12-06	QDQZ0ERB1206
D606▲	DIODE 1N5397-B or	NDLZ001N5397
▲	RECTIFIER DIODE ERB12-06	QDQZ0ERB1206
D607	ZENER DIODE MTZJT-7724C or	QDTC00MTZJ24
	ZENER DIODE DZ-24BSCT265	NDTC00DZ24BS
D609	SWITCHING DIODE 1SS133(T-77) or	QDTZ001SS133
	SWITCHING DIODE 1N4148	NDTZ001N4148
D610	ZENER DIODE MTZJT-775.6B or	QDTB0MTZJ5R6
	ZENER DIODE DZ-5.6BSBT265	NDTB0DZ5R6BS
D611	SWITCHING DIODE 1SS133(T-77) or	QDTZ001SS133
	SWITCHING DIODE 1N4148	NDTZ001N4148
D613▲	RECOVERY DIODE ERC18-04	QDZZ0ERC1804
D614▲	DIODE FR104-B	NDLZ000FR104
D615▲	DIODE 1ZC33 or	QDQZ0001ZC33
▲	ZENER DIODE RD33FB	QDQZ000RD33F
D616▲	SCHOTTKY BARRIER DIODE 21DQ04 or	QDQZ0021DQ04
▲	SCHOTTKY BARRIER DIODE ERB81-004	AERB81004***
D617▲	SCHOTTKY BARRIER DIODE 11EQS04 or	QD4Z011EQS04
▲	SCHOTTKY BARRIER DIODE ERA81-004	QDPZERA81004
D618	DIODE FR154 or	NDLZ000FR154
	FAST RECOVERY DIODE ERB44-02	QDPZ0ERB4402
D619	DIODE FR104-B	NDLZ000FR104
D620▲	ZENER DIODE MTZJT-776.8B or	QDTB0MTZJ6R8
▲	ZENER DIODE DZ-6.8BSBT265	NDTB0DZ6R8BS
D621	SWITCHING DIODE 1SS133(T-77) or	QDTZ001SS133
	SWITCHING DIODE 1N4148	NDTZ001N4148
D622	SWITCHING DIODE 1SS133(T-77) or	QDTZ001SS133
	SWITCHING DIODE 1N4148	NDTZ001N4148
D623	SWITCHING DIODE 1SS133(T-77) or	QDTZ001SS133
	SWITCHING DIODE 1N4148	NDTZ001N4148
D625	SWITCHING DIODE 1SS133(T-77) or	QDTZ001SS133
	SWITCHING DIODE 1N4148	NDTZ001N4148
D626	ZENER DIODE MTZJT-7736A or	QDTA00MTZJ36
	ZENER DIODE DZ-36BSAT265	NDTA00DZ36BS
D627	ZENER DIODE MTZJT-7716B or	QDTB00MTZJ16
	ZENER DIODE DZ-16BSBT265	NDTB00DZ16BS
D628	SWITCHING DIODE 1SS133(T-77) or	QDTZ001SS133
	SWITCHING DIODE 1N4148	NDTZ001N4148
D629	SWITCHING DIODE 1SS133(T-77) or	QDTZ001SS133
	SWITCHING DIODE 1N4148	NDTZ001N4148
D631	ZENER DIODE MTZJT-776.8A or	QDTA00MTZJ6R8
	ZENER DIODE DZ-6.8BSAT265	NDTA00DZ6R8BS
D632	SWITCHING DIODE 1SS133(T-77) or	QDTZ001SS133
	SWITCHING DIODE 1N4148	NDTZ001N4148
D633	SWITCHING DIODE 1SS133(T-77) or	QDTZ001SS133
	SWITCHING DIODE 1N4148	NDTZ001N4148
D634	ZENER DIODE MTZJT-778.2B or	QDTB0MTZJ8R2
	ZENER DIODE DZ-8.2BSBT265	NDTB0DZ8R2BS
D635	SWITCHING DIODE 1SS133(T-77) or	QDTZ001SS133
	SWITCHING DIODE 1N4148	NDTZ001N4148
D636	SWITCHING DIODE 1SS133(T-77) or	QDTZ001SS133
	SWITCHING DIODE 1N4148	NDTZ001N4148
D638	SWITCHING DIODE 1SS133(T-77) or	QDTZ001SS133
	SWITCHING DIODE 1N4148	NDTZ001N4148
D639	SCHOTTKY BARRIER DIODE 11EQS04 or	QD4Z011EQS04
	SCHOTTKY BARRIER DIODE ERA81-004	QDPZERA81004
D640	SWITCHING DIODE 1SS133(T-77) or	QDTZ001SS133
	SWITCHING DIODE 1N4148	NDTZ001N4148
D641▲	ZENER DIODE MTZJT-7736A or	QDTA00MTZJ36
▲	ZENER DIODE DZ-36BSAT265	NDTA00DZ36BS

Ref. No.	Description	Part No.
D646	SWITCHING DIODE 1SS133(T-77) or	QDTZ001SS133
	SWITCHING DIODE 1N4148	NDTZ001N4148
D649	ZENER DIODE MTZJT-7715B or	QDTB00MTZJ15
	ZENER DIODE DZ-15BSBT265	NDTB00DZ15BS
D801	SWITCHING DIODE 1SS133(T-77) or	QDTZ001SS133
	SWITCHING DIODE 1N4148	NDTZ001N4148
D802	SWITCHING DIODE 1SS133(T-77) or	QDTZ001SS133
	SWITCHING DIODE 1N4148	NDTZ001N4148
D803	SWITCHING DIODE 1SS133(T-77) or	QDTZ001SS133
	SWITCHING DIODE 1N4148	NDTZ001N4148
D964	SWITCHING DIODE 1SS133(T-77) or	QDTZ001SS133
	SWITCHING DIODE 1N4148	NDTZ001N4148
D965	ZENER DIODE MTZJT-776.2B or	QDTB0MTZJ6R2
	ZENER DIODE DZ-6.2BSBT265	NDTB0DZ6R2BS
<b>ICS</b>		
IC100	IC:VIF/SIF DETECTOR M61111FP	QSZBA0SMB010
IC201▲	MICROCONTROLLER 16BIT M37762M8A-8B1GP	QSZAA0RMB148
IC202	IC:MEMORY BR24C02F-W or	QSMBA0SRM003
	IC:MEMORY AT24C02N-10SC or	NSMMA0SAZ012
	IC(EEPROM) M24C02-MN6 or	NSMMA0SSS028
	IC:MEMORY BR24C02F or	QSMMA0SRM003
	IC:EEPROM CAT24WC02JI or	NSZBA0SBG001
	IC(EEP-ROM) M24C02-WMN6	NSZAA0SSS004
IC301▲	VCD IC M61275FP or	QSZAA0RMB133
▲	MICRO-COMPUTER/VCD M61275FP-61	QSZAB0RMB133
IC401	IC:Y/C/A LA71091M	QSZBA0RSY012
IC551▲	VERTICAL OUTPUT IC AN5522 or	QSZBA0SMS002
▲	VERTICAL OUTPUT IC LA78040A	QSBBA0SSY003
IC601▲	PHOTOCOUPLER LTV-817B-F or	NPEB0LTV817F
▲	PHOTOCOUPLER LTV-817C-F or	NPEC0LTV817F
▲	PHOTO COUPLER PC817X6	QPE600PC817X
IC602▲	VOLTAGE REGULATOR KIA7805API or	NSBBA0SJY011
▲	VOLTAGE REGULATOR KA7805A or	NSZBA0SF3052
▲	IC:VOLTAGE REGULATOR AN7805F	AN7805F
IC801	AUDIO AMP LA4224	QSZAA0SSY005
<b>COILS</b>		
L001	PCB JUMPER D0.6-P5.0	JW5.0T
L031	PCB JUMPER D0.6-P5.0	JW5.0T
L033	INDUCTOR 15μH-J-26T or	LLAXJATTU150
	INDUCTOR 15μH-K-26T	LLAXKDTKA150
L041	PCB JUMPER D0.6-P5.0	JW5.0T
L202	INDUCTOR 0.10μH-K-26T	LLAXKATTUR10
L211▲	CHOKE COIL 47μH-K or	LLBD00PKV007
▲	CHOKE COIL 47μH-K	LLBD00PKV005
L302	PCB JUMPER D0.6-P5.0	JW5.0T
L303	PCB JUMPER D0.6-P5.0	JW5.0T
L402	INDUCTOR 22μH-J-26T or	LLAXJATTU220
	INDUCTOR 22μH-K-26T	LLAXKDTKA220
L404	CHOKE COIL 47μH-K or	LLBD00PKV007
	CHOKE COIL 47μH-K	LLBD00PKV005
L557	CHOKE COIL 22μH-K	LLBD00PKV006
L601▲	LINE FILTER SA-91213B or	LLBG00ZSA002
▲	LINE FILTER TLF12UA302W1R0 or	LLBG00ZTU025
▲	LINE FILTER 5.0MH 6Y075	LLBG00ZKT004
L601	LINE FILTER UU10.5-A	LLBG00ZY2008
L601▲	LINE FILTER TLF14CB3321R0 or	LLBG00ZTU012
▲	LINE FILTER 6.35MH UU10-002	LLBG00ZKV001
L871	PCB JUMPER D0.6-P5.0	JW5.0T
L872	INDUCTOR 47μH-K-5FT or	LLARKBSTU470
	INDUCTOR 47μH-K-5FT	LLARKDSKA470

Ref. No.	Description	Part No.
<b>TRANSISTORS</b>		
Q205	TRANSISTOR 2SC2785(F) or	QQSF02SC2785
	TRANSISTOR 2SC2785(H) or	QQSH02SC2785
	TRANSISTOR 2SC2785(J) or	QQSJ02SC2785
	TRANSISTOR KTC3199(GR) or	NQS10KTC3199
	TRANSISTOR KTC3198(GR) or	NQS40KTC3198
	TRANSISTOR 2SC1815-GR(TPE2)	QQS102SC1815
Q206	PHOTO TRANSISTOR MID-32A22F	NPWZ1D32A22F
Q301	TRANSISTOR 2SC2785(F) or	QQSF02SC2785
	TRANSISTOR 2SC2785(H) or	QQSH02SC2785
	TRANSISTOR 2SC2785(J) or	QQSJ02SC2785
	TRANSISTOR KTC3199(GR) or	NQS10KTC3199
	TRANSISTOR KTC3198(GR) or	NQS40KTC3198
	TRANSISTOR 2SC1815-GR(TPE2)	QQS102SC1815
Q401	TRANSISTOR 2SA1175(F) or	QQSF02SA1175
	TRANSISTOR KTA1267(GR) or	NQS10KTA1267
	TRANSISTOR KTA1266(GR) or	NQS40KTA1266
	TRANSISTOR 2SA1015-GR(TPE2)	QQS102SA1015
Q402	TRANSISTOR 2SA1175(F) or	QQSF02SA1175
	TRANSISTOR KTA1267(GR) or	NQS10KTA1267
	TRANSISTOR KTA1266(GR) or	NQS40KTA1266
	TRANSISTOR 2SA1015-GR(TPE2)	QQS102SA1015
Q571▲	TRANSISTOR TT2140LS-YB11 or	QQZ00TT2140
▲	TRANSISTOR 2SC5885000RF	QQZ02SC5885
Q572	TRANSISTOR 2SC1627Y-TPE2	QQSY02SC1627
Q591▲	TRANSISTOR 2SC2785(F) or	QQSF02SC2785
▲	TRANSISTOR 2SC2785(H) or	QQSH02SC2785
▲	TRANSISTOR 2SC2785(J) or	QQSJ02SC2785
▲	TRANSISTOR KTC3199(GR) or	NQS10KTC3199
▲	TRANSISTOR KTC3198(GR) or	NQS40KTC3198
▲	TRANSISTOR 2SC1815-GR(TPE2)	QQS102SC1815
Q601▲	MOS FET 2SK2662	QF5Z02SK2662
Q602▲	TRANSISTOR 2SC2120-O-TPE2 or	QQS002SC2120
▲	TRANSISTOR 2SC2120-Y(TPE2)	QQSY02SC2120
Q604▲	TRANSISTOR 2SC2785(F) or	QQSF02SC2785
▲	TRANSISTOR 2SC2785(H) or	QQSH02SC2785
▲	TRANSISTOR 2SC2785(J) or	QQSJ02SC2785
▲	TRANSISTOR 2SC1815-GR(TPE2)	QQS102SC1815
Q605	TRANSISTOR 2SC2785(F) or	QQSF02SC2785
	TRANSISTOR 2SC2785(H) or	QQSH02SC2785
	TRANSISTOR 2SC2785(J) or	QQSJ02SC2785
	TRANSISTOR KTC3199(GR) or	NQS10KTC3199
	TRANSISTOR KTC3198(GR) or	NQS40KTC3198
	TRANSISTOR 2SC1815-GR(TPE2)	QQS102SC1815
Q606▲	TRANSISTOR 2SA950(O) or	Q2SA950TPE2
▲	TRANSISTOR 2SA950(Y) or	Q2SA950Y TPE2
▲	TRANSISTOR KTA1271(Y)	NQSY0KTA1271
Q607	TRANSISTOR 2SC2785(F) or	QQSF02SC2785
	TRANSISTOR 2SC2785(H) or	QQSH02SC2785
	TRANSISTOR 2SC2785(J) or	QQSJ02SC2785
	TRANSISTOR KTC3199(GR) or	NQS10KTC3199
	TRANSISTOR KTC3198(GR) or	NQS40KTC3198
	TRANSISTOR 2SC1815-GR(TPE2)	QQS102SC1815
Q608▲	TRANSISTOR 2SC2120-O-TPE2 or	QQS002SC2120
▲	TRANSISTOR 2SC2120-Y(TPE2) or	QQSY02SC2120
▲	TRANSISTOR KTC3203(Y)	NQSY0KTC3203
Q609	TRANSISTOR 2SC2120-O-TPE2 or	QQS002SC2120
	TRANSISTOR 2SC2120-Y(TPE2) or	QQSY02SC2120
	TRANSISTOR KTC3203(Y)	NQSY0KTC3203
Q610	TRANSISTOR 2SC2120-O-TPE2 or	QQS002SC2120

Ref. No.	Description	Part No.
	TRANSISTOR 2SC2120-Y(TPE2) or	QQSY02SC2120
	TRANSISTOR KTC3203(Y)	NQSY0KTC3203
Q611▲	TRANSISTOR 2SD400(F) or	QQUF002SD400
▲	TRANSISTOR 2SD400(E)	QQUE002SD400
Q612	RES. BUILT-IN TRANSISTOR KRA103M or	NQSZ0KRA103M
	RES. BUILT-IN TRANSISTOR BN1F4M-T	QQSZ00BN1F4M
Q871	TRANSISTOR 2SA1175(F) or	QQSF02SA1175
	TRANSISTOR KTA1267(GR) or	NQS10KTA1267
	TRANSISTOR KTA1266(GR) or	NQS40KTA1266
	TRANSISTOR 2SA1015-GR(TPE2)	QQS102SA1015
Q872	TRANSISTOR 2SC2120-O-TPE2 or	QQS002SC2120
	TRANSISTOR 2SC2120-Y(TPE2) or	QQSY02SC2120
	TRANSISTOR KTC3203(Y)	NQSY0KTC3203
Q873	TRANSISTOR 2SC3331(T) or	QSC3331TNPAA
	TRANSISTOR 2SC3331(U) or	QSC3331UNPAA
	TRANSISTOR 2SC1815-GR(TPE2)	QQS102SC1815
Q874	TRANSISTOR 2SC3331(T) or	QSC3331TNPAA
	TRANSISTOR 2SC3331(U) or	QSC3331UNPAA
	TRANSISTOR 2SC1815-GR(TPE2)	QQS102SC1815
Q875	RES. BUILT-IN TRANSISTOR KRA103M or	NQSZ0KRA103M
	RES. BUILT-IN TRANSISTOR BN1F4M-T	QQSZ00BN1F4M
<b>RESISTORS</b>		
R002	CHIP RES.(1608) 1/10W J 100 Ω	RRXAJB5Z0101
R003	CHIP RES.(1608) 1/10W J 100 Ω	RRXAJB5Z0101
R032	CARBON RES. 1/4W J 100 Ω	RCX4JATZ0101
R033	CARBON RES. 1/4W J 12k Ω	RCX4JATZ0123
R034	CARBON RES. 1/4W J 220 Ω	RCX4JATZ0221
R037	CHIP RES.(1608) 1/10W J 180 Ω	RRXAJB5Z0181
R038	CARBON RES. 1/4W J 180 Ω	RCX4JATZ0181
R039	CHIP RES.(1608) 1/10W J 180 Ω	RRXAJB5Z0181
R041	CHIP RES.(1608) 1/10W J 12k Ω	RRXAJB5Z0123
R042	CARBON RES. 1/4W J 3.9k Ω	RCX4JATZ0392
R046	CHIP RES.(1608) 1/10W J 220k Ω	RRXAJB5Z0224
R047	CHIP RES.(1608) 1/10W J 220k Ω	RRXAJB5Z0224
R053	CARBON RES. 1/4W J 220k Ω	RCX4JATZ0224
R201	CARBON RES. 1/4W G 4.7k Ω	RCX4GATZ0472
R202	CHIP RES. 1/10W F 22k Ω	RRXAFB5J2202
R203	CHIP RES. 1/10W F 470 Ω	RRXAFB5J4700
R204	CHIP RES. 1/10W F 1.5k Ω	RRXAFB5J1501
R205	CHIP RES. 1/10W F 3.6k Ω	RRXAFB5J3601
R206	CHIP RES. 1/10W F 10k Ω	RRXAFB5J1002
R208	CHIP RES.(1608) 1/10W J 22k Ω	RRXAJB5Z0223
R209	CHIP RES.(1608) 1/10W J 10k Ω	RRXAJB5Z0103
R210	CHIP RES.(1608) 1/10W J 1.5k Ω	RRXAJB5Z0152
R211	CHIP RES.(1608) 1/10W J 1.5k Ω	RRXAJB5Z0152
R212	CHIP RES.(1608) 1/10W J 2.2k Ω	RRXAJB5Z0222
R213	CHIP RES.(1608) 1/10W J 2.7k Ω	RRXAJB5Z0272
R214	CHIP RES.(1608) 1/10W J 10k Ω	RRXAJB5Z0103
R215	CHIP RES.(1608) 1/10W J 1.5k Ω	RRXAJB5Z0152
R216	CHIP RES.(1608) 1/10W J 1.5k Ω	RRXAJB5Z0152
R217	CHIP RES.(1608) 1/10W J 2.2k Ω	RRXAJB5Z0222
R218	CHIP RES.(1608) 1/10W J 2.7k Ω	RRXAJB5Z0272
R219	CHIP RES.(1608) 1/10W J 1k Ω	RRXAJB5Z0102
R220	CHIP RES.(1608) 1/10W J 390k Ω	RRXAJB5Z0394
R221	PCB JUMPER D0.6-P5.0	JW5.0T
R222	CHIP RES.(1608) 1/10W J 270k Ω	RRXAJB5Z0274
R223	CHIP RES.(1608) 1/10W J 560 Ω	RRXAJB5Z0561
R225	CHIP RES.(1608) 1/10W J 100 Ω	RRXAJB5Z0101
R227	CARBON RES. 1/4W J 270 Ω	RCX4JATZ0271
R229	CHIP RES.(1608) 1/10W J 330 Ω	RRXAJB5Z0331

Ref. No.	Description	Part No.
R233	CHIP RES.(1608) 1/10W J 2.2k Ω	RRXAJB5Z0222
R234	CHIP RES.(1608) 1/10W J 1.2k Ω	RRXAJB5Z0122
R235	CHIP RES.(1608) 1/10W J 47 Ω	RRXAJB5Z0470
R236	CHIP RES.(1608) 1/10W J 100k Ω	RRXAJB5Z0104
R237	CARBON RES. 1/4W J 1k Ω	RCX4JATZ0102
R238	CHIP RES.(1608) 1/10W J 470k Ω	RRXAJB5Z0474
R239	CHIP RES.(1608) 1/10W J 2.7k Ω	RRXAJB5Z0272
R240	CHIP RES.(1608) 1/10W 0 Ω	RRXAZB5Z0000
R241	CHIP RES.(1608) 1/10W J 5.6k Ω	RRXAJB5Z0562
R242	CHIP RES.(1608) 1/10W J 10k Ω	RRXAJB5Z0103
R243	CHIP RES.(1608) 1/10W J 1k Ω	RRXAJB5Z0102
R244	CHIP RES.(1608) 1/10W J 1M Ω	RRXAJB5Z0105
R245	CHIP RES.(1608) 1/10W J 470 Ω	RRXAJB5Z0471
R247	CHIP RES.(1608) 1/10W J 820 Ω	RRXAJB5Z0821
R248	CHIP RES.(1608) 1/10W J 470 Ω	RRXAJB5Z0471
R249	CARBON RES. 1/4W J 3.3k Ω	RCX4JATZ0332
R250	CHIP RES.(1608) 1/10W J 1.5k Ω	RRXAJB5Z0152
R251	CHIP RES.(1608) 1/10W J 3.3k Ω	RRXAJB5Z0332
R252	CHIP RES.(1608) 1/10W J 1.5k Ω	RRXAJB5Z0152
R253	CARBON RES. 1/4W J 3.3k Ω	RCX4JATZ0332
R254	CHIP RES.(1608) 1/10W J 1.5k Ω	RRXAJB5Z0152
R255	PCB JUMPER D0.6-P5.0	JW5.0T
R256	CARBON RES. 1/4W J 5.6k Ω	RCX4JATZ0562
R257	PCB JUMPER D0.6-P5.0	JW5.0T
R258	PCB JUMPER D0.6-P5.0	JW5.0T
R259	CARBON RES. 1/4W J 5.6k Ω	RCX4JATZ0562
R260	PCB JUMPER D0.6-P5.0	JW5.0T
R262	CHIP RES.(1608) 1/10W J 220k Ω	RRXAJB5Z0224
R263	CHIP RES.(1608) 1/10W J 39k Ω	RRXAJB5Z0393
R267	CARBON RES. 1/4W J 33k Ω	RCX4JATZ0333
R270	CHIP RES.(1608) 1/10W J 100k Ω	RRXAJB5Z0104
R273	CHIP RES.(1608) 1/10W J 1.8k Ω	RRXAJB5Z0182
R274	CHIP RES.(1608) 1/10W J 680 Ω	RRXAJB5Z0681
R278	CARBON RES. 1/4W J 1k Ω	RCX4JATZ0102
R279	CHIP RES.(1608) 1/10W J 10k Ω	RRXAJB5Z0103
R281	CARBON RES. 1/4W J 10k Ω	RCX4JATZ0103
R282	CARBON RES. 1/4W J 2.7k Ω	RCX4JATZ0272
R283	PCB JUMPER D0.6-P5.0	JW5.0T
R291	CHIP RES.(1608) 1/10W J 10k Ω	RRXAJB5Z0103
R292	CHIP RES.(1608) 1/10W J 22k Ω	RRXAJB5Z0223
R301	CARBON RES. 1/4W J 330 Ω	RCX4JATZ0331
R303	CARBON RES. 1/4W J 330 Ω	RCX4JATZ0331
R305	CARBON RES. 1/4W J 330 Ω	RCX4JATZ0331
R308	CARBON RES. 1/4W J 120k Ω	RCX4JATZ0124
R310	CARBON RES. 1/4W J 180k Ω	RCX4JATZ0184
R312	CHIP RES.(1608) 1/10W J 100 Ω	RRXAJB5Z0101
R314	CHIP RES.(1608) 1/10W J 100 Ω	RRXAJB5Z0101
R315	CHIP RES.(1608) 1/10W J 100 Ω	RRXAJB5Z0101
R316	CHIP RES.(1608) 1/10W J 8.2k Ω	RRXAJB5Z0822
R329	CARBON RES. 1/4W J 15k Ω	RCX4JATZ0153
R331	CHIP RES.(1608) 1/10W J 100 Ω	RRXAJB5Z0101
R332	CARBON RES. 1/2W J 39 Ω or CARBON RES. 1/2W J 39 Ω	RCX2JZQZ0390 RCX2390KA013
R333	CHIP RES.(1608) 1/10W J 100 Ω	RRXAJB5Z0101
R334	CHIP RES.(1608) 1/10W J 56k Ω	RRXAJB5Z0563
R335	CHIP RES.(1608) 1/10W J 5.6k Ω	RRXAJB5Z0562
R336	CHIP RES.(1608) 1/10W J 10k Ω	RRXAJB5Z0103
R337	CHIP RES.(1608) 1/10W J 1k Ω	RRXAJB5Z0102
R338	CHIP RES.(1608) 1/10W J 18k Ω	RRXAJB5Z0183
R339	CHIP RES.(1608) 1/10W J 10k Ω	RRXAJB5Z0103
R340	CARBON RES. 1/4W J 1k Ω	RCX4JATZ0102

Ref. No.	Description	Part No.
R406	CARBON RES. 1/4W J 47k Ω	RCX4JATZ0473
R407	CHIP RES.(1608) 1/10W J 47k Ω	RRXAJB5Z0473
R409	CHIP RES.(1608) 1/10W J 18k Ω	RRXAJB5Z0183
R413	CHIP RES.(1608) 1/10W J 39k Ω	RRXAJB5Z0393
R414	CHIP RES.(1608) 1/10W J 4.7k Ω	RRXAJB5Z0472
R415	CHIP RES.(1608) 1/10W J 1.5k Ω	RRXAJB5Z0152
R416	CHIP RES.(1608) 1/10W J 100k Ω	RRXAJB5Z0104
R417	CHIP RES.(1608) 1/10W J 220 Ω	RRXAJB5Z0221
R418	CHIP RES.(1608) 1/10W J 330 Ω	RRXAJB5Z0331
R419	CARBON RES. 1/4W J 330 Ω	RCX4JATZ0331
R423	CHIP RES.(1608) 1/10W J 5.6M Ω	RRXAJB5Z0565
R424	CHIP RES.(1608) 1/10W J 100k Ω	RRXAJB5Z0104
R425	CHIP RES.(1608) 1/10W J 82k Ω	RRXAJB5Z0823
R426	CHIP RES.(1608) 1/10W J 2.2k Ω	RRXAJB5Z0222
R427	CARBON RES. 1/4W J 820 Ω	RCX4JATZ0821
R428	CHIP RES.(1608) 1/10W J 680k Ω	RRXAJB5Z0684
R429	CHIP RES.(1608) 1/10W J 1.5k Ω	RRXAJB5Z0152
R431	CHIP RES.(1608) 1/10W J 8.2k Ω	RRXAJB5Z0822
R435	CHIP RES.(1608) 1/10W J 2k Ω	RRXAJB5Z0202
R544	CHIP RES.(1608) 1/10W J 10k Ω	RRXAJB5Z0103
R551	CHIP RES.(1608) 1/10W J 1.5k Ω	RRXAJB5Z0152
R552▲	CARBON RES. 1/4W J 1.5k Ω	RCX4JATZ0152
R556	CARBON RES. 1/4W J 4.7 Ω	RCX4JATZ0477
R557	CARBON RES. 1/4W J 470 Ω	RCX4JATZ0471
R558	CARBON RES. 1/4W J 15k Ω	RCX4JATZ0153
R559	CARBON RES. 1/4W J 820 Ω	RCX4JATZ0821
R560	CARBON RES. 1/4W J 5.1k Ω	RCX4JATZ0512
R561	CARBON RES. 1/4W J 5.6k Ω	RCX4JATZ0562
R562	CARBON RES. 1/4W J 4.7 Ω	RCX4JATZ0477
R563	CARBON RES. 1/4W J 4.7 Ω	RCX4JATZ0477
R565	CARBON RES. 1/4W J 4.7 Ω	RCX4JATZ0477
R566	CARBON RES. 1/4W J 4.7 Ω	RCX4JATZ0477
R568	CARBON RES. 1/4W J 1.5k Ω	RCX4JATZ0152
R570	CARBON RES. 1/4W J 4.7 Ω	RCX4JATZ0477
R571	CARBON RES. 1/4W J 180 Ω	RCX4JATZ0181
R572	CARBON RES. 1/4W J 1k Ω	RCX4JATZ0102
R573	CARBON RES. 1/4W J 1k Ω	RCX4JATZ0102
R574▲	METAL OXIDE FILM RES. 2W J 1k Ω or ▲ METAL OXIDE FILM RES. 2W J 1k Ω	RN02102ZU001 RN02102DP004
R575▲	METAL OXIDE FILM RES. 2W J 1k Ω or ▲ METAL OXIDE FILM RES. 2W J 1k Ω	RN02102ZU001 RN02102DP004
R576	CARBON RES. 1/4W J 1k Ω	RCX4JATZ0102
R577	CARBON RES. 1/4W J 180 Ω	RCX4JATZ0181
R578	CARBON RES. 1/4W J 4.7 Ω	RCX4JATZ0477
R579	CARBON RES. 1/4W J 56 Ω	RCX4JATZ0560
R580	CARBON RES. 1/4W J 56 Ω	RCX4JATZ0560
R581	CARBON RES. 1/4W J 56 Ω	RCX4JATZ0560
R583	METAL OXIDE FILM RES. 2W J 1.5 Ω or METAL OXIDE FILM RES. 2W J 1.5 Ω	RN021R5ZU001 RN021R5DP004
R584	CARBON RES. 1/4W J 1k Ω	RCX4JATZ0102
R586	CARBON RES. 1/4W J 100 Ω	RCX4JATZ0101
R587▲	CARBON RES. 1/4W J 100k Ω ▲ CARBON RES. 1/4W J 100k Ω	RCX4JATZ0104 RCX4JATZ0104
R588	CARBON RES. 1/4W J 100k Ω	RCX4JATZ0104
R590	METAL OXIDE FILM RES. 1W J 3.3k Ω or METAL OXIDE FILM RES. 1W J 3.3k Ω	RN01332ZU001 RN01332DP003
R592▲	CARBON RES. 1/4W J 180k Ω ▲ CARBON RES. 1/4W J 180k Ω	RCX4JATZ0184 RCX4JATZ0184
R593	CHIP RES.(1608) 1/10W J 68k Ω	RRXAJB5Z0683
R594	CHIP RES.(1608) 1/10W J 56k Ω	RRXAJB5Z0563
R595	CARBON RES. 1/4W J 15k Ω	RCX4JATZ0153
R596	CARBON RES. 1/4W J 6.8k Ω	RCX4JATZ0682
R597	CHIP RES.(1608) 1/10W J 1.2k Ω	RRXAJB5Z0122



Ref. No.	Description	Part No.
R598	CHIP RES.(1608) 1/10W J 22k Ω	RRXAJB5Z0223
R599	CHIP RES.(1608) 1/10W J 10k Ω	RRXAJB5Z0103
R602▲	CEMENT RES. 5W K 1.2 Ω or	RW051R2DP005
▲	CEMENT RESISTOR 5W K 1.2 Ω	RW051R2PG001
R603	METAL OXIDE FILM RES. 2W J 0.27 Ω or	RN02R27ZU001
	METAL OXIDE FILM RES. 2W J 0.27 Ω	RN02R27DP004
R604	CARBON RES. 1/4W J 1.2M Ω	RCX4JATZ0125
R605	CARBON RES. 1/4W J 1.2M Ω	RCX4JATZ0125
R606	CARBON RES. 1/4W J 180 Ω	RCX4JATZ0181
R607	CARBON RES. 1/4W J 180 Ω	RCX4JATZ0181
R608	CARBON RES. 1/4W J 180k Ω	RCX4JATZ0184
R610	CARBON RES. 1/4W J 1k Ω	RCX4JATZ0102
R613	CARBON RES. 1/4W J 150 Ω	RCX4JATZ0151
R614	CHIP RES.(1608) 1/10W J 1.2k Ω	RRXAJB5Z0122
R616	CARBON RES. 1/4W J 2.2 Ω	RCX4JATZ02R2
R617	CARBON RES. 1/4W J 180 Ω	RCX4JATZ0181
R618	CARBON RES. 1/4W J 560 Ω	RCX4JATZ0561
R619	CARBON RES. 1/2W J 1k Ω or	RCX2JZQZ0102
	CARBON RES. 1/2W J 1k Ω	RCX2102KA013
R620	METAL OXIDE FILM RES. 2W J 8.2k Ω or	RN02822ZU001
	METAL OXIDE FILM RES. 2W J 8.2k Ω	RN02822DP004
R621	CARBON RES. 1/4W J 15k Ω	RCX4JATZ0153
R622	CARBON RES. 1/4W J 15k Ω	RCX4JATZ0153
R623	CHIP RES.(1608) 1/10W J 33k Ω	RRXAJB5Z0333
R624▲	CARBON RES. 1/4W J 39k Ω	RCX4JATZ0393
R625	CARBON RES. 1/4W J 47k Ω	RCX4JATZ0473
R629	CARBON RES. 1/4W J 13k Ω	RCX4JATZ0133
R630	CARBON RES. 1/4W J 13k Ω	RCX4JATZ0133
R631	CARBON RES. 1/4W J 13k Ω	RCX4JATZ0133
R632	CARBON RES. 1/4W J 560 Ω	RCX4JATZ0561
R633	CHIP RES.(1608) 1/10W J 5.6k Ω	RRXAJB5Z0562
R634	CHIP RES.(1608) 1/10W J 6.8k Ω	RRXAJB5Z0682
R635	CHIP RES.(1608) 1/10W J 10k Ω	RRXAJB5Z0103
R637	METAL OXIDE FILM RES. 2W J 8.2k Ω or	RN02822ZU001
	METAL OXIDE FILM RES. 2W J 8.2k Ω	RN02822DP004
R639▲	CARBON RES. 1/2W J 1k Ω or	RCX2JZQZ0102
▲	CARBON RES. 1/2W J 1k Ω	RCX2102KA013
R640	CHIP RES.(1608) 1/10W J 56k Ω	RRXAJB5Z0563
R641	CARBON RES. 1/4W J 10k Ω	RCX4JATZ0103
R642	CARBON RES. 1/4W J 5.6k Ω	RCX4JATZ0562
R643	CARBON RES. 1/4W J 27 Ω	RCX4JATZ0270
R644	CHIP RES.(1608) 1/10W J 47k Ω	RRXAJB5Z0473
R647	CARBON RES. 1/2W J 1.8 Ω	RCX2JZQZ01R8
R648	CARBON RES. 1/2W J 6.8 Ω or	RCX2JZQZ06R8
	CARBON RES. 1/2W J 6.8 Ω	RCX26R8KA013
R650▲	CARBON RES. 1/4W J 22 Ω	RCX4JATZ0220
R651	CARBON RES. 1/4W J 470 Ω	RCX4JATZ0471
R652	CARBON RES. 1/4W J 470 Ω	RCX4JATZ0471
R653	CARBON RES. 1/4W J 100 Ω	RCX4JATZ0101
R654	METAL OXIDE FILM RES. 1W J 15 Ω or	RN01150ZU001
	METAL OXIDE FILM RES. 1W J 15 Ω	RN01150DP003
R655	CARBON RES. 1/4W J 2.7k Ω	RCX4JATZ0272
R656	METAL OXIDE FILM RES. 1W J 5.6 Ω or	RN015R6ZU001
	METAL OXIDE FILM RES. 1W J 5.6 Ω	RN015R6DP003
R659	CHIP RES.(1608) 1/10W J 100 Ω	RRXAJB5Z0101
R660	PCB JUMPER D0.6-P5.0	JW5.0T
R662	CARBON RES. 1/4W J 22 Ω	RCX4JATZ0220
R670	CARBON RES. 1/4W J 120 Ω	RCX4JATZ0121
R701	CHIP RES.(1608) 1/10W J 75 Ω	RRXAJB5Z0750
R801	METAL OXIDE FILM RES. 1W J 18 Ω or	RN01180ZU001
	METAL OXIDE FILM RES. 1W J 18 Ω	RN01180DP003

Ref. No.	Description	Part No.
R802	CARBON RES. 1/4W J 4.7k Ω	RCX4JATZ0472
R803	CHIP RES.(1608) 1/10W J 2.2k Ω	RRXAJB5Z0222
R804	CHIP RES.(1608) 1/10W J 4.7k Ω	RRXAJB5Z0472
R805	CHIP RES.(1608) 1/10W J 10k Ω	RRXAJB5Z0103
R806	CARBON RES. 1/4W J 47 Ω	RCX4JATZ0470
R807	CARBON RES. 1/4W J 47 Ω	RCX4JATZ0470
R851	CHIP RES.(1608) 1/10W J 22k Ω	RRXAJB5Z0223
R852	CHIP RES.(1608) 1/10W J 3.9k Ω	RRXAJB5Z0392
R853	CHIP RES.(1608) 1/10W J 2.2M Ω	RRXAJB5Z0225
R856	CHIP RES.(1608) 1/10W J 22k Ω	RRXAJB5Z0223
R857	CHIP RES.(1608) 1/10W J 3.3k Ω	RRXAJB5Z0332
R858	CHIP RES.(1608) 1/10W J 6.8k Ω	RRXAJB5Z0682
R859	CHIP RES.(1608) 1/10W J 4.7k Ω	RRXAJB5Z0472
R861	CHIP RES.(1608) 1/10W J 6.8k Ω	RRXAJB5Z0682
R862	CHIP RES.(1608) 1/10W J 2.7k Ω	RRXAJB5Z0272
R863	CHIP RES.(1608) 1/10W J 10k Ω	RRXAJB5Z0103
R864	CHIP RES.(1608) 1/10W J 8.2k Ω	RRXAJB5Z0822
R865	CHIP RES.(1608) 1/10W J 12k Ω	RRXAJB5Z0123
R866	CHIP RES.(1608) 1/10W J 330k Ω	RRXAJB5Z0334
R867	CHIP RES.(1608) 1/10W J 270 Ω	RRXAJB5Z0271
R868	CHIP RES.(1608) 1/10W J 18k Ω	RRXAJB5Z0183
R869	CHIP RES.(1608) 1/10W J 820 Ω	RRXAJB5Z0821
R871	CARBON RES. 1/4W J 1k Ω	RCX4JATZ0102
R872	CHIP RES.(1608) 1/10W J 22k Ω	RRXAJB5Z0223
R873	CARBON RES. 1/4W J 18k Ω	RCX4JATZ0183
R874	CARBON RES. 1/4W J 100 Ω	RCX4JATZ0101
R875	CHIP RES.(1608) 1/10W J 2.2k Ω	RRXAJB5Z0222
R876	CHIP RES.(1608) 1/10W J 2.2k Ω	RRXAJB5Z0222
R877	CARBON RES. 1/4W J 820 Ω	RCX4JATZ0821
R980	CARBON RES. 1/4W J 6.8k Ω	RCX4JATZ0682
R981	CARBON RES. 1/2W J 1.2 Ω	RCX2JZQZ01R2
SWITCHES		
SW201	TACT SWITCH SKQNAED010 or	SST0101AL055
	TACTILE SWITCH KSHG612BT	SST0101HH027
SW202	TACT SWITCH SKQNAED010 or	SST0101AL055
	TACTILE SWITCH KSHG612BT	SST0101HH027
SW203	TACT SWITCH SKQNAED010 or	SST0101AL055
	TACTILE SWITCH KSHG612BT	SST0101HH027
SW204	TACT SWITCH SKQNAED010 or	SST0101AL055
	TACTILE SWITCH KSHG612BT	SST0101HH027
SW205	TACT SWITCH SKQNAED010 or	SST0101AL055
	TACTILE SWITCH KSHG612BT	SST0101HH027
SW206	TACT SWITCH SKQNAED010 or	SST0101AL055
	TACTILE SWITCH KSHG612BT	SST0101HH027
SW207	TACT SWITCH SKQNAED010 or	SST0101AL055
	TACTILE SWITCH KSHG612BT	SST0101HH027
SW208	TACT SWITCH SKQNAED010 or	SST0101AL055
	TACTILE SWITCH KSHG612BT	SST0101HH027
SW209	TACT SWITCH SKQNAED010 or	SST0101AL055
	TACTILE SWITCH KSHG612BT	SST0101HH027
SW210	TACT SWITCH SKQNAED010 or	SST0101AL055
	TACTILE SWITCH KSHG612BT	SST0101HH027
SW211	LEAF SWITCH LSA-1142-2AU or	SSC0101KB014
	LEAF SWITCH MXS00052MPP0 or	SSC0101MCE01
	LEAF SWITCH MXS00981MPP0	SSC0101MCE02
SW212	ROTARY MODE SWITCH SSS-50MD or	SSR0106KB002
	ROTARY MODE SWITCH R8100245	SSR0106U3002
MISCELLANEOUS		
BC571	BEAD INDUCTORS FBA04HA600VB-00	LLBF00STU026
BC601	PCB JUMPER D0.6-P5.0	JW5.0T

Ref. No.	Description	Part No.
BC602	BEAD INDUCTORS FBR07HA121TB-00	LLBF00ZTU021
BC603	BEAD INDUCTORS FBR07HA121TB-00	LLBF00ZTU021
BC605	BEAD INDUCTORS FBR07HA121TB-00	LLBF00ZTU021
BC606	BEAD INDUCTORS FBR07HA121TB-00	LLBF00ZTU021
CF031	CERAMIC TRAP 4.5MHz or 4.5M TRAP XT4.5MB2	FBE455PMR003 FBE455PLN001
CF032	CERAMIC FILTER SFSRA4M50CF00-B0 or 4.5M FILTER LTH4.5MCB	FBB455PMR004 FBB455PLN001
CL201	FMN CONNECTOR, TOP 12P 12FMN-BTRK	JCFNG12JG002
F601▲	FUSE 4.00A/125V or ▲ FUSE 51MS040L or ▲ FUSE STC4A125V U/CT or ▲ FUSE 4.00A/125V	PAGU20CAG402 PAFC20CHV402 PAGE20CW3402 PAGG20CNG402
FH601	FUSE HOLDER MSF-015	XH01Z00LY001
FH601▲	FUSE HOLDER FH-V-03078	XH01Z00DK001
FH602	FUSE HOLDER MSF-015	XH01Z00LY001
FH602▲	FUSE HOLDER FH-V-03078	XH01Z00DK001
J125	CHIP RES.(1608) 1/10W 0 Ω	RRXAZB5Z0000
JK701	RCA JACK(YELLOW) MSP-281V4-B or RCA JACK(YELLOW) AV1-15-3	JXRL010LY003 JXRL010RP013
JK702	RCA JACK(WHITE) MSP-281V1-B or RCA JACK(WHITE) AV1-15-4	JXRL010LY005 JXRL010RP014
JK801	EARPHONE JACK MSJ-035-12APC or EARPHONE JACK HTJ-035-1ZEBTZ or EARPHONE JACK HSJ1403-01-010	JYSL030LY001 JYSL030GE001 JYSL030HD002
PS601▲	THERMISTOR ZPB45BL7R0A	QNZ245BL7R0A
RS201	REMOTE RECEIVER PIC-37042LU	USE5JRSKK033
SA601▲	SURGE ABSORBER JVR-07N471K or ▲ SURGE ABSORBER CNR-10D471K or ▲ SURGE ABSORBER CNR-07D471K or ▲ SURGE ABSORBER PVR-07D471KB	NVQZVR07N471 NVQZR10D471K NVQZR07D471K NVQZ07D471KB
SF001	SAW FILTER SAFGM45M7VHHzC0B03	FBB456PMR008
SG001▲	GAP FNR-G3.10D	FAZ000LD6005
T571▲	FLYBACK TRANSFORMER JF0501-3201A or ▲ FLYBACK TRANS BSC22-2697S	LTF00CPXB040 LTF00CPS2055
T572	HORIZONTAL DRIVE TRANS LP2-005	LTH00CPA5005
T601▲	SWITCHING TRANS 02712	LTT00CPKT101
TB3	HEAD SHIELD(DC) T5400UA	0EM301721
TB7	LED HOLDER T5400UA	0EM407679
TB9	19VPOW HEAT SINK PHB ASSEMBLYT7400UA	0EM407685
TB21	BUSH, LED(F) H3700UD	0VM409508
TB26	13V H/V HEAT SINK PGZ T5400UA	0EM301720
TL2	SCREW, B-TIGHT M3X8 BIND HEAD+ or SCREW, B-TIGHT M3X8 BIND HEAD+	GBMB3080 GBMB3080
TP201	PCB JUMPER D0.6-P5.0	JW5.0T
TP301	PCB JUMPER D0.6-P17.5	JW17.5T
TP302	PCB JUMPER D0.6-P5.0	JW5.0T
TP401	PCB JUMPER D0.6-P20.0	JW20.0T
TP402	PCB JUMPER D0.6-P17.5	JW17.5T
TU001▲	TUNER B8135AP or ▲ TUNER ENV56DC9G3	UTUNNTUSP023 UTUNNTUMS010
VR601▲	CARBON P.O.T. 10k Ω B or ▲ CARBON P.O.T. 10k Ω B	VRCB103KA011 VRCB103HH014
W601▲	AC CORD PB8K9F9110A-057 or ▲ AC CORD WAC0172LTE01 or ▲ AC CORD WAC0172AS006 or ▲ AC CORD LA-2366 or ▲ AC CORD A0A0280-007	WAC0172LW008 WAC0172LTE01 WAC0172AS006 WAC0172LW006 WAC0172LTE04
X201	X'TAL 32.768kHz(20PPM) or X'TAL 32.768kHz(20PPM) or X'TAL 32.768kHz(20PPM) or	FXC323LJNY01 FXC323LCT001 FXC323LDS002

Ref. No.	Description	Part No.
	X'TAL 32.768kHz(20PPM) or	FXC323LQUA01
	X'TAL 32.768kHz(20PPM)	FXC323LCHE01
X202	X'TAL HC-49/U 10.6MHz or X'TAL AT49-10.6 or X'TAL :10.6MHz S8562	FXD106LLN001 FXD106LDS002 FXD106LCT001
X301	X'TAL 3.579545 MHz or X'TAL 3.579545MHz(30PPM)	FXD355LLN003 FXD355LCHE01
X401	X'TAL 3.579545MHz(20PPM) or X'TAL 3.579545MHz(20PPM) or X'TAL 3.579545MHz(20PPM) or X'TAL 3.579545MHz or X'TAL 3.579545MHz(20PPM)	FXC355LJNY01 FXC355LLN003 FXC355LDS001 FXC355LLN001 FXC355LCHE01

## CRT CBA

Ref. No.	Description	Part No.
	CRT CBA Consists of the following	-----
<b>CAPACITORS</b>		
C501	CERAMIC CAP. B K 1000pF/2KV or CERAMIC CAP. B K 1000pF/2KV or CERAMIC CAP. B K 1000pF/2KV	CCD3DKP0B102 CA3D102MR030 CCD3DKD0B102
C502	ELECTROLYTIC CAP. 1μF/50V M or ELECTROLYTIC CAP. 1μF/50V M or ELECTROLYTIC CAP. 1μF/50V M	CE1JMASDL1R0 CE1JMASDL010 CE1JMASTL1R0
C511	CHIP CERAMIC CAP. B K 470pF/50V	CHD1JKB0B471
C521	CHIP CERAMIC CAP. B K 470pF/50V	CHD1JKB0B471
C531	CHIP CERAMIC CAP. B K 470pF/50V	CHD1JKB0B471
<b>CONNECTORS</b>		
CN505	PIN CONNECTOR 005P-5100 or CONNECTOR PIN, 1P LV or CONNECTOR PIN, 1P RT01N-2.3A	JTEA001TG001 1700576 1730688
<b>TRANSISTORS</b>		
Q511	TRANSISTOR 2SC2482 TPE6 or TRANSISTOR 2SC3468(E)-AE or TRANSISTOR 2SC3468(D)-AE or TRANSISTOR KTC3207	QQS202SC2482 QQSE02SC3468 QQSD02SC3468 NQS20KTC3207
Q521	TRANSISTOR 2SC2482 TPE6 or TRANSISTOR 2SC3468(E)-AE or TRANSISTOR 2SC3468(D)-AE or TRANSISTOR KTC3207	QQS202SC2482 QQSE02SC3468 QQSD02SC3468 NQS20KTC3207
Q531	TRANSISTOR 2SC2482 TPE6 or TRANSISTOR 2SC3468(E)-AE or TRANSISTOR 2SC3468(D)-AE or TRANSISTOR KTC3207	QQS202SC2482 QQSE02SC3468 QQSD02SC3468 NQS20KTC3207
<b>RESISTORS</b>		
R510▲	METAL OXIDE FILM RES. 1W J 15k Ω or ▲ METAL OXIDE FILM RES. 1W J 15k Ω	RN01153ZU001 RN01153DP003
R511	CHIP RES.(1608) 1/10W J 15 Ω	RRXAJB5Z0150
R512	CARBON RES. 1/4W J 56k Ω	RCX4JATZ0563
R513	CARBON RES. 1/4W J 56k Ω	RCX4JATZ0563
R515	CARBON RES. 1/4W J 470 Ω	RCX4JATZ0471
R516	CARBON RES. 1/4W J 1.5k Ω	RCX4JATZ0152
R517	CARBON RES. 1/4W J 1.5k Ω	RCX4JATZ0152
R520▲	METAL OXIDE FILM RES. 1W J 15k Ω or ▲ METAL OXIDE FILM RES. 1W J 15k Ω	RN01153ZU001 RN01153DP003
R521	CHIP RES.(1608) 1/10W J 15 Ω	RRXAJB5Z0150
R522	CARBON RES. 1/4W J 56k Ω	RCX4JATZ0563
R523	CARBON RES. 1/4W J 56k Ω	RCX4JATZ0563
R525	CARBON RES. 1/4W J 470 Ω	RCX4JATZ0471

Ref. No.	Description	Part No.
R526	CARBON RES. 1/4W J 1.5k $\Omega$	RCX4JATZ0152
R527	CARBON RES. 1/4W J 1.5k $\Omega$	RCX4JATZ0152
R530▲	METAL OXIDE FILM RES. 1W J 15k $\Omega$ or	RN01153ZU001
▲	METAL OXIDE FILM RES. 1W J 15k $\Omega$	RN01153DP003
R531	CHIP RES.(1608) 1/10W J 15 $\Omega$	RRXAJB5Z0150
R532	CARBON RES. 1/4W J 56k $\Omega$	RCX4JATZ0563
R533	CARBON RES. 1/4W J 56k $\Omega$	RCX4JATZ0563
R535	CARBON RES. 1/4W J 470 $\Omega$	RCX4JATZ0471
R536	CARBON RES. 1/4W J 1.5k $\Omega$	RCX4JATZ0152
R537	CARBON RES. 1/4W J 1.5k $\Omega$	RCX4JATZ0152
<b>MISCELLANEOUS</b>		
CL501A	LEAD WIRE 3P/410MM	WX1T7400-001
CL502A	LEAD WIRE 4P/480MM	WX1T7400-002
JK501▲	GRT SOCKET ISMS02S	JSCC220PK003

## SENSOR CBA

Ref. No.	Description	Part No.
	SENSOR CBA Consists of the following	0ESA04524
<b>TRANSISTORS</b>		
Q201	PHOTO TRANSISTOR MID-32A22F	NPWZ1D32A22F
Q202	PHOTO TRANSISTOR MID-32A22F	NPWZ1D32A22F

# DECK PARTS LIST

## NOTE:

Four different, but interchangeable, types of B558 (LOADING MOTOR) may be installed in these models. Please confirm B558 (LOADING MOTOR) type by a part number on it. B558 (LOADING MOTOR) type varies in combination with L1151. Please see Table 1 for details and combination.

**Table 1 (B558 and L1151 Combination)**

LOADING MOTOR (B558)		SCREW (L1151)	
Description	Parts No.	Description	Parts No.
LOADING MOTOR M31E-1 R-14 7376	MMDZB12MM003	SCREW, SEMS M2.6X4 PAN HEAD+	CPM39040
LOADING MOTOR M31E-1 R-14 7391	MMDZB12MM004		
LOADING MOTOR MDB2B80	MMDZB12SJ008	SCREW, SEMS M3X4 PAN HEAD+	CPM33040
LOADING MOTOR MDB2B82	MMDZB10SJ001		

Ref. No	Description	Part No.
B2	CYLINDER ASSEMBLY MK12 NTSC 2HD	N1628CYL
B3	LOADING MOTOR ASSEMBLY MK11 TVCR	0VSA13465
B8	PULLEY ASSEMBLY MK12	0VSA13500
B9	MOVING GUIDE S PREPARATION MK12	0VSA13560
B10	MOVING GUIDE T PREPARATION MK12	0VSA13562
B11	LOADING ARM(TU) ASSEMBLY MK12	0VSA13300
B12	LOADING ARM(SP) ASSEMBLY MK12	0VSA13299
B31	AC HEAD ASSEMBLY MK12(TVCR)	0VSA13517
B35	TAPE GUIDE ARM ASSEMBLY MK12	0VSA13277
B37	CAPSTAN MOTOR 288/VCCM012	N9670CML
B52	CAP BELT MK10	0VM411138
B73	FE HEAD ASSEMBLY MK11 or	N9742FEL
	FE HEAD ASSEMBLY MK11 or	N9743FEL
	FE HEAD(MK11) MH-131SF11 or	DHVEC01Z0005
	FE HEAD(MK11) VTR-1X2ERS11-148 or	DHVEC01TE004
	FE HEAD(MK12) VTR-1X2ERS11-155 or	DHVEC01TE005
	FE HEAD(MK12) HVFHP0047A	DHVEC01AL007
B74	PRISM MK10	0VM202870
B121	WORM MK12	0VM414091
B126	PULLEY MK12	0VM414330B
B133	IDLER GEAR MK12	0VM305738
B134	IDLER ARM MK12	0VM305739
B148	TG CAP MK11	0VM412972
B300	C DRIVE LEVER(TU) MK12	0VM203773
B303	F DOOR OPENER MK12	0VM203751C
B313	C DRIVE SPRING MK12	0VM414145
B347	GUIDE HOLDER A MK10	0VM304920
B354	SLIDER(TU) MK12	0VM101172F
B355	SLIDER(SP) MK12 or	0VM101182F
	SLIDER(SP) SUB ASSEMBLY MK12 or	0VDM12542
	SLIDER(SP) MK12	0VM101182H
B359	CLEANER LEVER MK10	0VM304413
B360	CLEANER ROLLER MK9	0VM410032C
B361	CL POST MK10	0VM411114
B410	PINCH ARM(A) ASSEMBLY(4) MK12 or	0VSA13572

Ref. No	Description	Part No.
	PINCH ARM(A) ASSEMBLY(5) MK12	0VSA13788
B411	PINCH SPRING MK12	0VM414644
B414	M BRAKE(SP) ASSEMBLY MK12	0VSA13282
B416	M BRAKE(TU) ASSEMBLY MK12	0VSA13283
B417	TENSION SPG(3002654) MK12	0VM414221E
B425	LOCK LEVER SPRING MK10	0VM411110
B426	KICK PULLEY MK10	0VM411095
B482	CASSETTE PLATE MK12	0VM203749
B483	LOCK LEVER MK12	0VM414095
B487	BAND BRAKE(SP) MK12	0VM305723
B488	MODE LEVER MK12	0VM1011173
B491	CAM GEAR(A) MK12	0VM1011174
B492	MODE GEAR MK12	0VM203769
B494	C DOOR OPENER MK12	0VM305719
B499	T LEVER HOLDER MK12	0VM305729
B501	WORM HOLDER MK12	0VM203767
B502	CAM GEAR(B) MK12	0VM305721
B507	REEL WASHER MK9 5*2.1*0.5	0VM410058
B508	S BRAKE SPRING MK10	0VM411121
B513	CAM WASHER MK12	0VM414741
B514	SCREW RACK MK10	0VM411535
B516	REEL WASHER MK9 5*2.1*0.5	0VM410058
B520	TU BRAKE SPRING MK12	0VM414285
B521	REV BRAKE SPRING MK12	0VM414222
B522	TG POST ASSEMBLY MK11	0VSA12080
B525	LDG BELT MK11	0VM412804
B529	CLEANER ASSEMBLY MK10	0VSA11161
B553	REV SPRING MK11	0VM412555
B555	RACK ASSEMBLY MK12	0VSA13289
B557	MOTOR PULLEY U5 or	0VM403205A
	MOTOR PULLEY U5	0VM403205A
B558	LOADING MOTOR MDB2B82 or	MMDZB10SJ001
	LOADING MOTOR MDB2B80 or	MMDZB12SJ008
	LOADING MOTOR M31E-1 R-14 7376 or	MMDZB12MM003
	LOADING MOTOR M31E-1 R14 7391	MMDZB12MM004
B559	CLUTCH ASSEMBLY MK12	0VSA13284
B560	KICK SPRING MK10	0VM411475A
B561	F DOOR SPRING MK10	0VM411430
B562	C DRIVE LEVER(SP) MK12	0VM203772
B563	SLIDER SHAFT MK12	0VM305762
B564	M GEAR MK12	0VM305735
B565	SENSOR GEAR MK12	0VM305736
B567	PINCH ARM(B) MK12	0VM305718
B568	BT ARM MK12	0VM305728
B569	CAM HOLDER(F) MK12	0VM305722
B570	CAM RACK SPRING(HI) MK11	0VM412923
B571	P.S.W CUT 1.6X4.0X0.5T	0VM408485A
B573	REEL(SP)(D2) MK12	0VM203755
B574	REEL(TU)(D2) MK12	0VM203756
B587	TENSION LEVER ASSEMBLY MK12	0VSA13279
B590	BRAKE ARM(TU) MK12	0VM203752E
B591	BAND BRAKE(TU) MK12	0VM305724C
B592	TG POST MK11	0VM412550
L1051	SCREW, B-TIGHT M2.6X6 PAN HEAD+	GPMB9060
L1053	SCREW, S-TIGHT M2.6X8 WASHER HEAD+	GCMS9080
L1151	SCREW, SEMS M3X4 PAN HEAD + or	CPM33040
	SCREW, SEMS M2.6X4 PAN HEAD+	CPM39040
L1191	SCREW, S-TIGHT M2.6X8 WASHER HEAD+	GCMS9080

<b>Ref. No</b>	<b>Description</b>	<b>Part No.</b>
L1321	SCREW, S-TIGHT M3X6 BIND HEAD+	GBMS3060
L1341	SCREW, P-TIGHT 2X8 PAN HEAD +	GPMP2080
L1406	AC HEAD SCREW MK9	0VM410964
L1450	SCREW, SEMS M2.6X5 PAN HEAD+	CPM39050
L1466	SCREW, S-TIGHT M2.6X6 BIND HEAD+	GBMS9060
L1467	SCREW, S-TIGHT M2.6X5 WASHER HEAD+	GCMS9050

C6319CD

T7404CE